

MACHINE ROLLER, VHMS-15

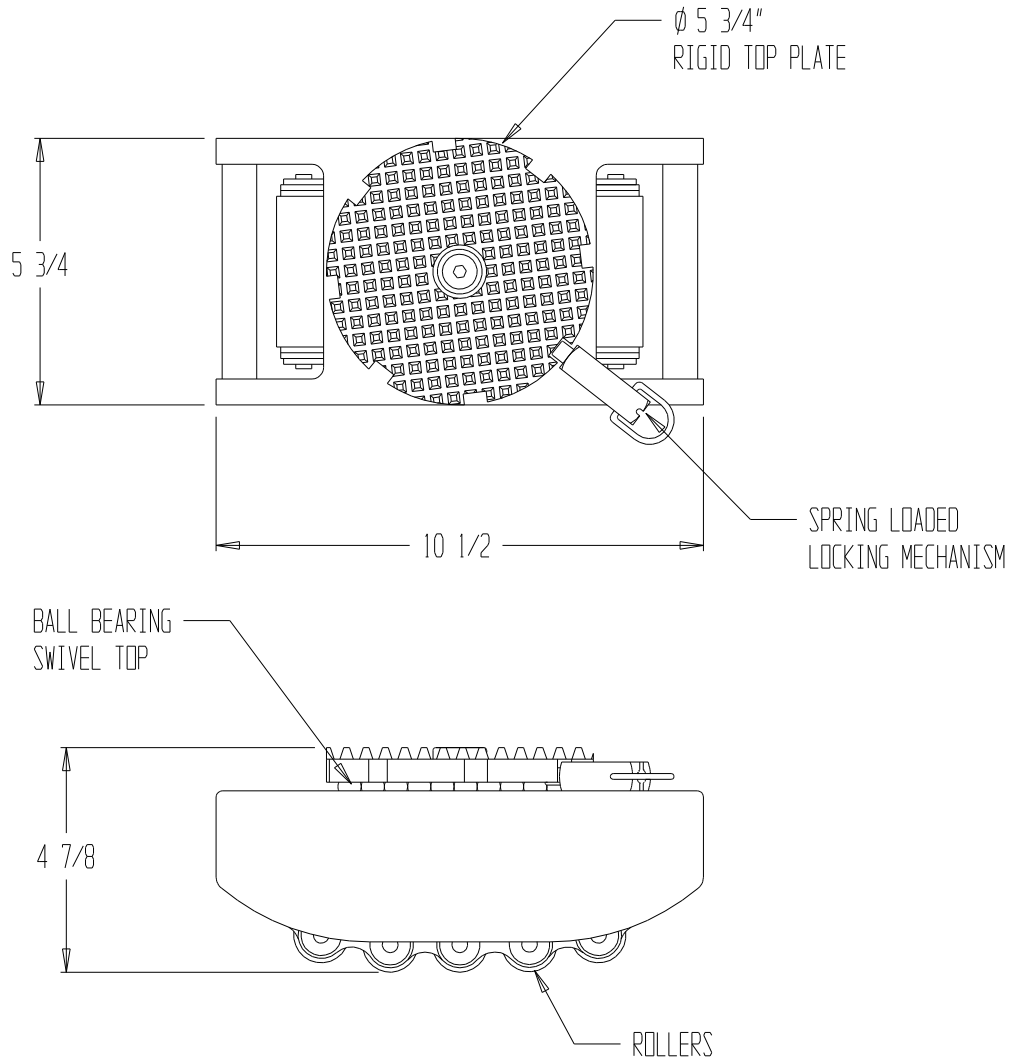

STANDARD FEATURES

MODEL NUMBER: VHMS-15
 CAPACITY: 22,000 LBS
 OVERALL WIDTH: 5 3/4"
 OVERALL LENGTH: 10 1/2"
 OVERALL HEIGHT: 4 7/8"
 RIGID Ø 5 3/4" TOP PLATE
 ROLLER LENGTH: 3 1/4"
 ROLLER DIA: Ø 1 3/16"
 DURABLE BAKED IN POWDER COATED BLUE FINISH

All graphics provided are for reference only.
 If certain dimensions are critical please
 verify those dimensions with your salesperson

APPROVAL	I, THE UNDERSIGNED, AGREE THAT THE PRODUCT AS REPRESENTED SATISFIES DESIGN & DIMENSION REQUIREMENTS. I ALSO ACKNOWLEDGE MY DUTY TO CONFIRM PRODUCT & INSTALLATION COMPLIANCE WITH ALL APPLICABLE FEDERAL, STATE AND LOCAL REGULATIONS & STANDARDS.	
	UNITS REQUIRING APPROVAL DRAWINGS OR MODIFIED ARE NON-RETURNABLE	
	() As drawn () As marked	
	Signed: _____	Date: _____
Printed Name _____		
LEAD TIME WILL START UPON RECEIPT OF SIGNED APPROVAL DRAWING		

SPECIAL FEATURES

NONE

PRODUCTION WILL START UPON
 RECEIPT OF SIGNED APPROVAL
 DRAWING

**SPECIAL UNITS ARE NON-RETURNABLE
 *AVAILABLE AT ADDITIONAL COSTS

DISTRIBUTOR'S NAME:		P.O.#: -
VESTIL MANUFACTURING		W.O.#: -
DRAWN BY: -	DATE: -	SALES: -
REFERENCE: -	SCALE: 1:4	DRWG./FILE NAME:
QUOTED LEADTIME: -	QUOTE #: -	VHMS-15