

# STEEL HOOK BASE 44 W RPB-2 ATTACHMENT - HOOK-BASE-44-RPB-2

APPROX WEIGHT: 141.28 lbs.

DOES NOT INCLUDE WEIGHT OF POWER OR PACKAGING!!!

\*\*\* ANY ADDITIONS, DELETIONS, OR OMISSIONS MUST BE CORRECTED ON THIS DRAWING AS THIS DRAWING WILL BE CONSIDERED ALL INCLUSIVE \*\*\*

ALL GRAPHICS PROVIDED ARE FOR REFERENCE ONLY. IF CERTAIN DIMENSIONS ARE CRITICAL PLEASE VERIFY THOSE DIMENSIONS WITH YOUR SALESPERSON

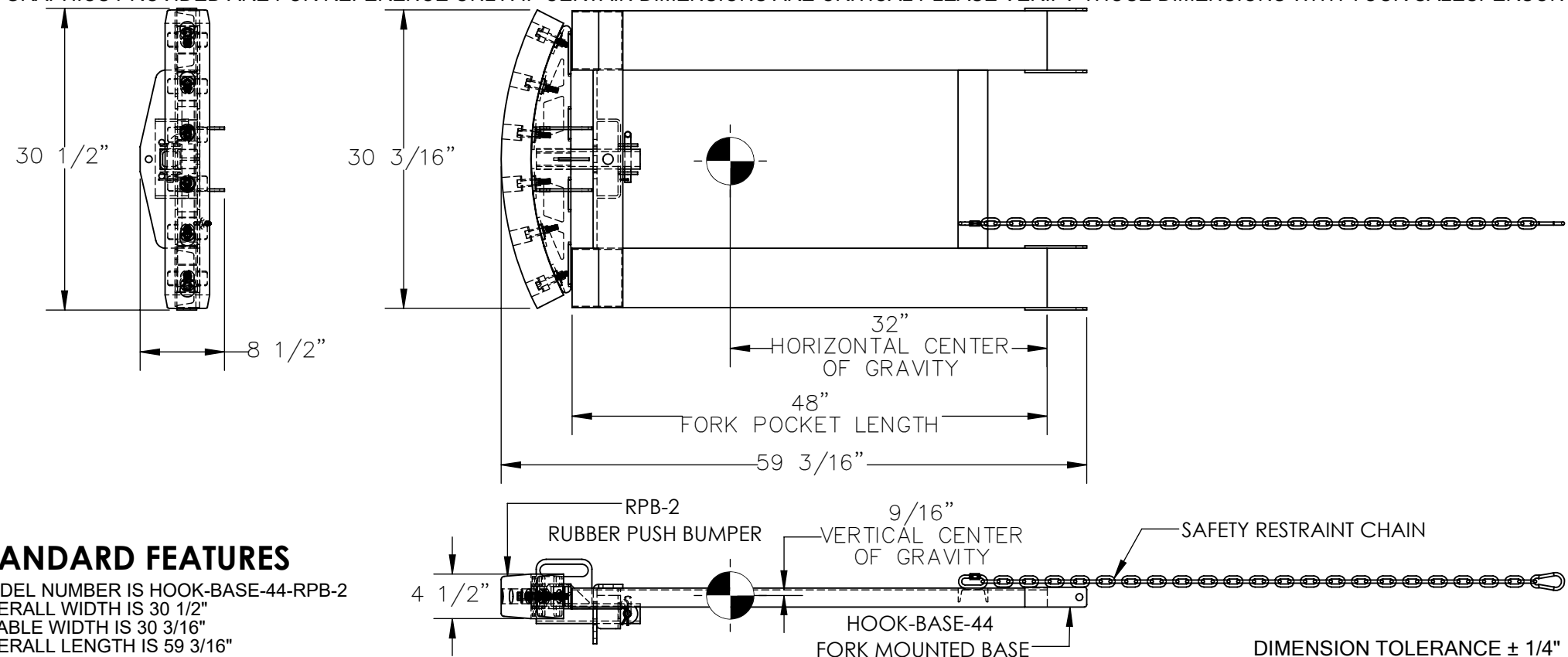

## STANDARD FEATURES

- MODEL NUMBER IS HOOK-BASE-44-RPB-2
- OVERALL WIDTH IS 30 1/2"
- USABLE WIDTH IS 30 3/16"
- OVERALL LENGTH IS 59 3/16"
- OVERALL HEIGHT IS 8 1/2"
- USABLE HEIGHT IS 4 1/2"
- ACCOMODATES UP TO A 5" WIDE x 2" THICK FORK
- SAFETY RESTRAINT CHAIN
- MINIMUM FORK LENGTH IS 48"
- BASE: DURABLE BAKED IN POWDER COATED BLUE FINISH
- ATTACHMENT: DURABLE BAKED IN POWDER COATED YELLOW FINISH

- APPROX. WEIGHT / LOST LOAD = 141.28 LBS
- MINIMUM EFFECTIVE THICKNESS = FORK LENGTH - 48"
- VERTICAL CENTER OF GRAVITY = 9/16"
- HORIZONTAL CENTER OF GRAVITY = 32"

- NEVER EXCEED LOAD CENTER
- RATING PER FORKTRUCK
- MANUFACTURERS GUIDELINES.
- DO NOT USE THIS FORK TRUCK
- ATTACHMENT IF LOAD WILL EXCEED
- FORK TRUCK MANUFACTURER'S
- LOAD CENTER RATING

## SPECIAL FEATURES

NONE

DIMENSION TOLERANCE ± 1/4"

|  |  |             |
|--|--|-------------|
| <b>APPROVAL</b>  | I, THE UNDERSIGNED, AGREE THAT THE PRODUCT AS REPRESENTED SATISFIES DESIGN AND DIMENSION REQUIREMENTS. I ALSO ACKNOWLEDGE MY DUTY TO CONFIRM PRODUCT AND INSTALLATION COMPLIANCE WITH ALL APPLICABLE FEDERAL, STATE AND LOCAL REGULATIONS AND STANDARDS. |             |
|  | <b>UNITS REQUIRING APPROVAL DRAWINGS OR MODIFIED ARE NON-RETURNABLE</b>  |             |
|  | [ ] As drawn      [ ] As marked  |             |
|  | Signed: _____  | Date: _____ |
| Printed Name: _____  |  |             |
| LEAD TIME WILL START UPON RECEIPT OF SIGNED APPROVAL DRAWING |  |             |

|                             |                         |            |
|-----------------------------|-------------------------|------------|
| DISTRIBUTOR'S NAME:         |                         | P.O.#      |
| <b>VESTIL MANUFACTURING</b> |                         | X          |
|                             |                         | W.O.#      |
| DRAWN BY: <b>AJS</b>        | DATE: <b>02/14/2025</b> | SALES: X   |
| REFERENCE: X                | SCALE: 1:15             | FILE NAME: |
| QUOTED LEAD TIME: X         | QUOTE # X               | 08-007-521 |