

HYDRAULIC DRUM CRUSHER/ COMPACTOR- HDC-905-IDC/460V

APPROX WEIGHT: 1203.99 lbs.
DOES NOT INCLUDE WEIGHT OF POWER OR PACKAGING!!!

*** ANY ADDITIONS, DELETIONS, OR OMISSIONS MUST BE CORRECTED ON THIS DRAWING AS THIS DRAWING WILL BE CONSIDERED ALL INCLUSIVE ***
ALL GRAPHICS PROVIDED ARE FOR REFERENCE ONLY. IF CERTAIN DIMENSIONS ARE CRITICAL PLEASE VERIFY THOSE DIMENSIONS WITH YOUR SALESPERSON

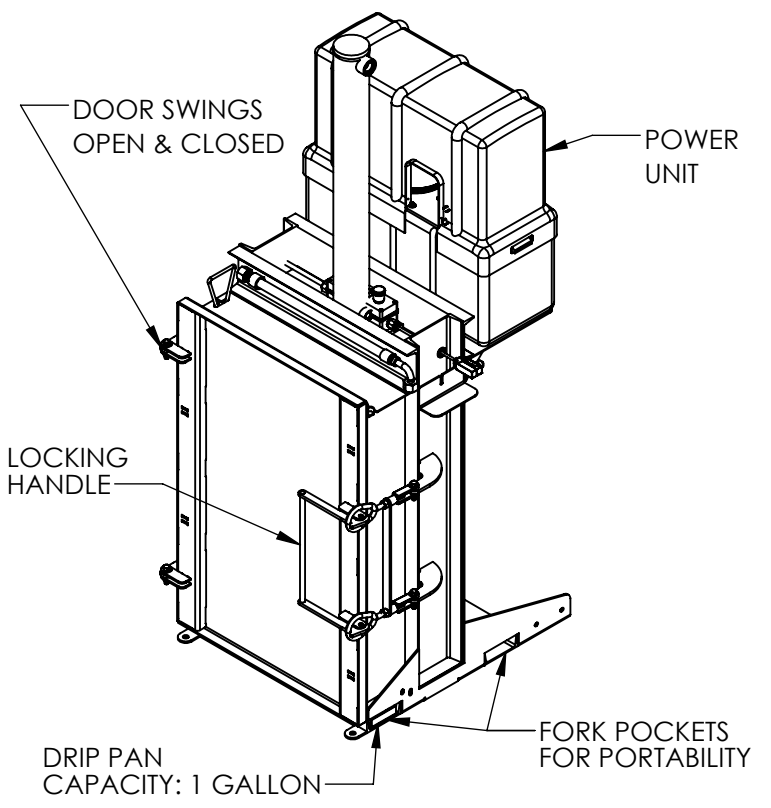
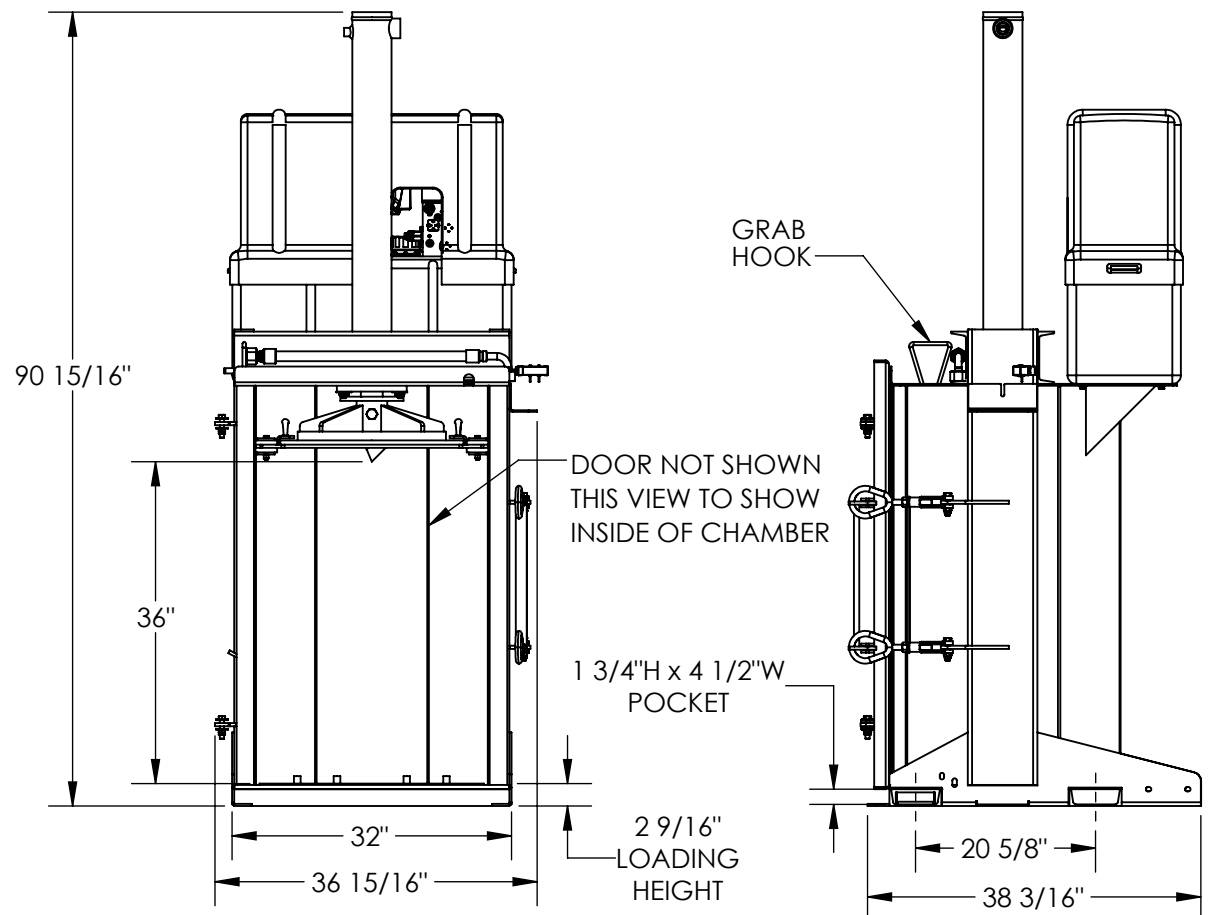

DIMENSION TOLERANCE ± 1/4"

STANDARD FEATURES

- DRUM CRUSHER AND COMPACTOR MODEL NUMBER HDC-905-IDC/460V
- FITS STEEL AND FIBER DRUMS WITH MAX Ø 23-1/2" x 35-1/2" HIGH
- POSITIVE DRUM POSITIONING
- DRUM HEAD PIERCER TO RELEASE INTERNAL DRUM PRESSURE
- 4" DIA. PISTON CYLINDER W/ 36" OF STROKE
- FULL CYCLE TIME OF 25 SECONDS (CRUSH AND RETRACT)
- STANDARD DUTY CYCLE ALLOWS MAX 250 CYCLES PER WEEK IN NORMAL ENVIRONMENT W/ 3PH POWER
- HYDRAULIC SYSTEM PRESSURE RATING: 3000 PSI W/ HYDRAULIC SYSTEM RELIEF VALVE
- 38,000 LBS. OF CRUSHING FORCE REDUCES STEEL DRUMS TO ONLY 6" HIGH
- 24V CONTROL CIRCUIT WITH:
 - ON/OFF KEY SWITCH
 - CYCLE START BUTTON
 - & CRUSH / COMPACT SELECTOR SWITCH
- TWO PRESSURE SWITCHES: HIGH PRESSURE FOR CRUSHING & LOW PRESSURE FOR COMPACTING
- Ø 21" COMPACTING PLATE COMPACTS CONTENTS INSIDE A 55 GALLON DRUM
- DOOR INTERLOCK SWITCH
- 6.5 HP MOTOR (PREWIRED FOR 460V 3PH) & 2-SPEED HYD. GEAR PUMP (11 GPM)
- STEEL CONSTRUCTION WITH DURABLE LIQUID PAINT BLUE FINISH

SPECIAL FEATURES

NONE

460V 3 PHASE AC POWER

CONTACT FACTORY FOR
OTHER POWER OPTIONS

**A
P
P
R
O
V
A
L**

I, THE UNDERSIGNED, AGREE THAT THE PRODUCT AS REPRESENTED SATISFIES DESIGN AND DIMENSION REQUIREMENTS. I ALSO ACKNOWLEDGE MY DUTY TO CONFIRM PRODUCT AND INSTALLATION COMPLIANCE WITH ALL APPLICABLE FEDERAL, STATE AND LOCAL REGULATIONS AND STANDARDS.

UNITS REQUIRING APPROVAL DRAWINGS OR MODIFIED ARE NON-RETURNABLE

As drawn As marked

Signed: _____ Date: _____

Printed Name: _____

LEAD TIME WILL START UPON RECEIPT OF SIGNED APPROVAL DRAWING

DISTRIBUTOR'S NAME:		P.O.#
VESTIL MANUFACTURING		X
DRAWN BY: TAW		W.O.#
DATE: 8/8/2016		X
REFERENCE: X	SCALE: 1:22	SALES: X
QUOTED LEAD TIME: X	QUOTE #	FILE NAME:
	X	22-007-017-003