

OPERATING INSTRUCTIONS

AND SUGGESTED ACTIVITIES

FOUCAULT'S PENDULUM APPARATUS

FCPN01

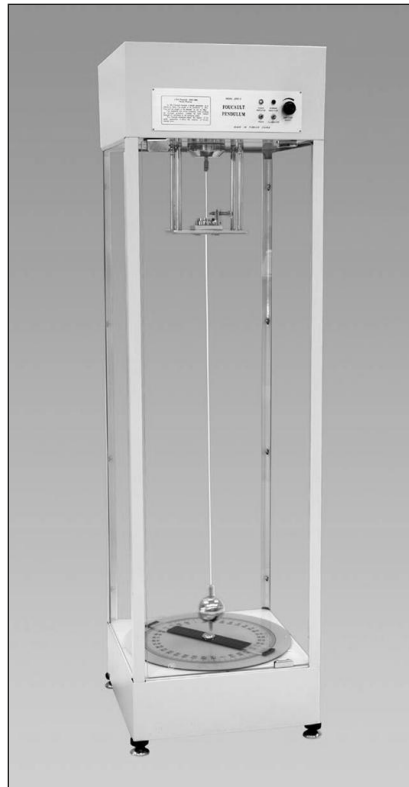

INTRODUCTION

Jean Bernard Léon Foucault's famous 1851 experiment with a long pendulum in the Panthéon in Paris used a 27 kg pendulum bob suspended on a 67m wire, and demonstrated that the pendulum's plane of swing precessed with the rotation of the Earth. This was the first direct dynamic evidence that the Earth rotates about a polar axis, and the phenomenon has been a popular topic of discussion ever since.

The precession of Foucault's pendulum is often poorly explained. At the Earth's poles, the plane of the swing remains constant relative to the fixed stars and appears to an Earth-based observer to rotate once every sidereal day. At the equator, the plane of swing co-rotates with the Earth and the pendulum does not appear to precess at all. At other latitudes, the behavior is intermediate between these extremes and the pendulum precesses with respect to both the Earth and the fixed stars. At 30° latitude, the apparent precession takes two days. If the motion is analyzed using a co-rotating coordinate system, then the force causing the precession is just the Coriolis force experienced by the moving bob.

This Foucault's Pendulum Apparatus is a carefully constructed miniature version of Foucault's device. Since the forces causing the precession are small, the effect is easily disturbed by other small environmental forces. To eliminate drafts, the pendulum is enclosed in a glass case, and the heavy vibration-damping base is equipped with leveling feet. The pendulum is electrically maintained to counter air resistance damping, and the swing amplitude can be adjusted using a potentiometer.

The suspension device ensures accurate centering of the pendulum's rest position over a graduated circle below the bob. The graduated circle carries an adjustable double-ended indicator bar for precise measurement of the plane of swing when tracking the precession rate.

The durable steel case is attractively finished suitable for permanent display, with a plaque carrying a brief description of Foucault's experiment.

SPECIFICATIONS AND DESCRIPTION

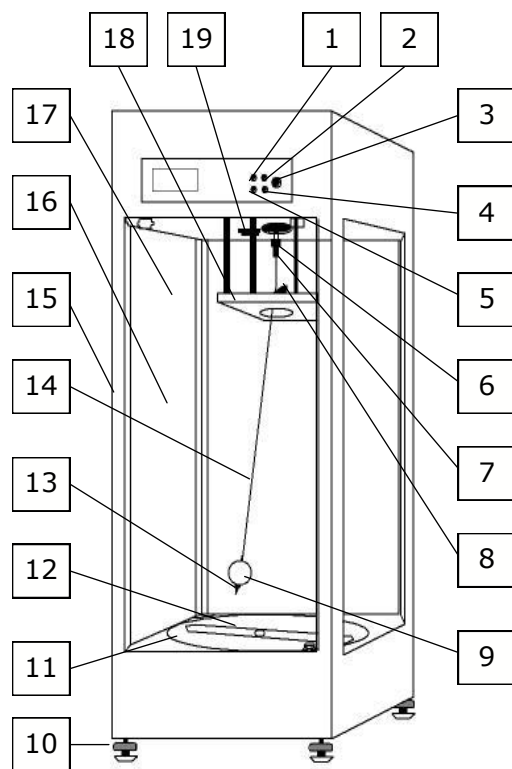

Figure 1

Refer to Figure 1 above

- | | |
|---------------------------------------|--|
| 1. Power indicator lamp | 11. 360° graduated disk |
| 2. Maintenance voltage indicator lamp | 12. Double-ended indicator bar |
| 3. Amplitude adjustment knob | 13. Pointer |
| 4. Illuminating lamp switch | 14. Pendulum wire (0.3mm diameter steel) |
| 5. Power switch | 15. Case frame |
| 6. Pendulum support | 16. Glass side panel |
| 7. Pendulum wire attachment clamp | 17. Glass door |
| 8. Centering device | 18. Centering device plate with centering ring |
| 9. Pendulum bob | 19. Illuminating lamp |
| 10. Leveling foot (one of four) | |

SPECIFICATIONS

Pendulum length:	975mm	Mass of bob:	approx.1kg
Period:	approx. 1.9s	Period tolerance:	$\leq \pm 10\%$
Power:	110VAC $\pm 10\%$, 50-60Hz		
Environment:	0—40°C, $\leq 85\%$ RH		
Dimensions:	40 cm x 40 cm x 140 cm	Weight:	approx. 50 kg

DESCRIPTION

The instrument is mounted in a steel cabinet with glass windows on three sides and a glass door at the front for protection against drafts. The door allows access to the pendulum and indicator bar for adjustment. The pendulum support and centering mechanism, and also the electrical equipment for illuminating the pendulum and controlling its motion, are mounted in the upper part of the cabinet, with the controls arranged on a front panel (see *Figure 2.*) Four adjustment feet allow the instrument to be set up vertically using a bubble level mounted on the base.

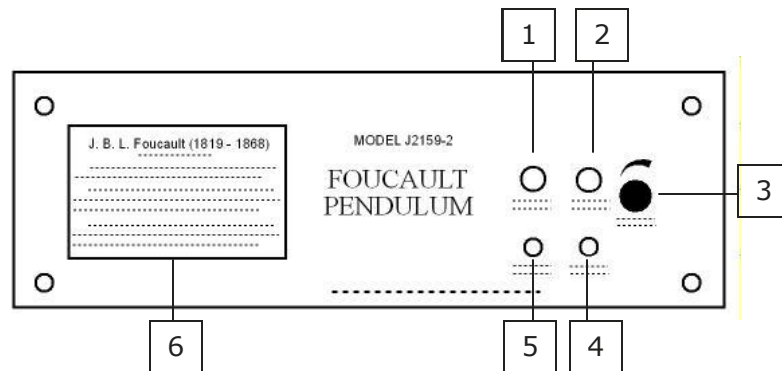

Figure 2

1. Power indicator lamp
2. Maintenance voltage indicator lamp
3. Amplitude adjustment knob
4. Illuminating lamp switch
5. Power switch
6. Plaque with Foucault background data

The pendulum consists of a length of 0.3 mm diameter steel wire carrying a spherical cast iron bob. The upper end of the wire is attached to a central clamp mounted in the base of the upper cabinet section. The wire then passes through a limiting ring in the center of a horizontal plate that carries a calibration screw and feeler used to ensure that the wire passes through the exact center of the ring. The lower end of the bob carries a pointer. The base of the cabinet is fitted with a circular disk graduated 360° for reading the plane of the pendulum swing. An indicator bar mounted at the center of the disk can be rotated by hand to mark the starting angle of the plane of swing. The lower section of the cabinet also contains the electromagnet used to maintain the pendulum's swing amplitude.

OPERATING PRINCIPLE

As mentioned in the introduction, the swinging pendulum experiences a Coriolis force due to the rotation of the earth. This rotation causes the suspension of the pendulum to move in a circle relative to a fixed point in space. The diameter of the circle and the angle its axis makes with pendulum's local vertical direction both depend on the geographic latitude of the pendulum. This angle is the determining factor in the pendulum's precession, since