

TU-631

DRIVER UNIT (FOR SPEAKER)



The TU-631 is a highly intelligible driver unit suited to public address announcement applications. Use the driver unit in combination with a suitable horn (optional). Its powder-coated finish and stainless steel screws ensure the unit's weatherproof capability.

Key features

- Low-impedance (16 Ω) model
- Power rating: 30 W
- Frequency Response: 150 Hz – 6 kHz
- IP65 certified weatherproof construction

Specifications

Compatible Horn	TH-650, TH-660
Horn Coupling	1 - 3/8 18 threads (inch screw)
Rated Input	30 W
Rated Impedance	16 Ω
Sound Pressure Level	110 dB (1 W, 1 m) (When operated with JIS C 5504 standard horn.)
Frequency Response	150 Hz - 6 kHz (When operated with JIS C 5504 standard horn.)
Polarity	Hot: Black, Com: White
Dust/Water Protection	IP65 (When a driver is operated with a horn.)
Operating Temperature	-20 # to +60 # (-4 # to +140 #) (no condensation)
Finish	Flange: Aluminum, gray, powder coating Rear cover: ABS resin, gray Screws: Stainless steel Speaker cable: Polyvinyl chloride insulated cabtyre cable (6 mm (0.24) in diameter)
Dimensions	#139 x 106 (D) mm (#5.47 x 4.17")
Weight	1.4 kg (3.09 lb)
Optional Accessories	Driver unit cover: UC-200A Matching transformer: TM-30T, TM-60T

Dimensions

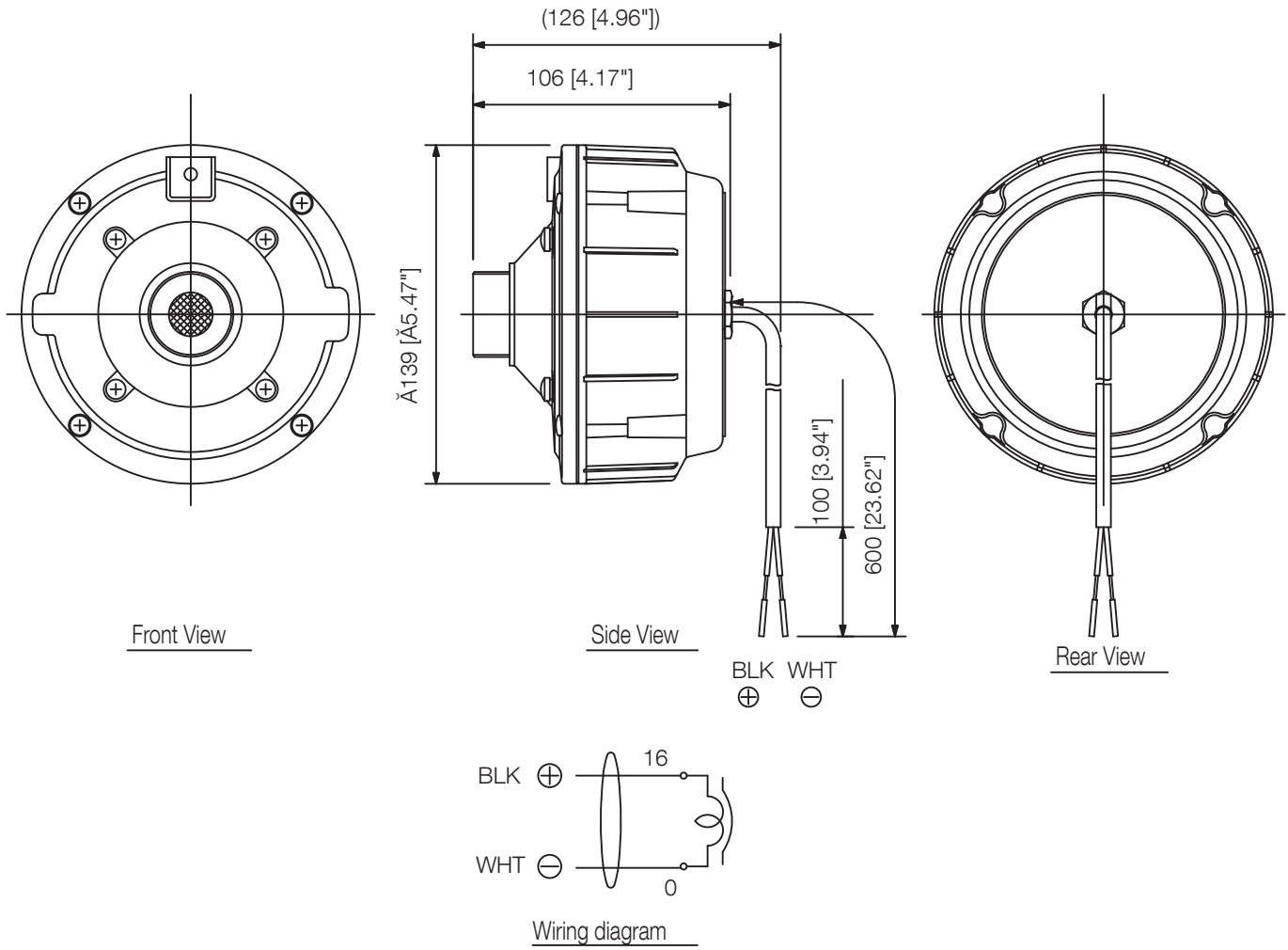

UNIT:mm SCALE:1/3

A&E specifications

The Driver Unit shall be designed to be used in combination with an optional round horn. The driver unit/horn combined speaker can be used for both indoor and outdoor applications, as well as for background music reproduction. The driver lineup shall include four models rated at 30 W and 50 W. The models designed for use in high-impedance (70V/100V lines) systems and standard models for low-impedance (16 Ω) systems shall be available. This wide product lineup shall permit selection of the ideal speaker for most applications.

The Driver Unit shall feature newly developed diaphragms employing special heat-resistant polyimide film to prevent the diaphragm from absorbing moisture and changing shape, as well as to improve the low frequency characteristics. High speaker efficiency shall have also been realized by minimizing the gap produced when the diaphragm bobbin is installed in the magnetic circuitry slit. High-impedance models shall be equipped with an input impedance selector switch which facilitates impedance settings without requiring disassembly. The switch shall be also equipped with an OFF position to prevent speaker damage resulting from incorrect impedance setting.

The Driver Unit shall be the TOA model TU-631/631M/651/651M.