

SP-410

SPEAKER BRACKET



The SP-410 bracket is used to mount a box speaker to a wall or surface. It can be installed in combination with a 2-unit electrical box and can easily set or change the speaker orientation.

Key features

- Designed to mount a box speaker to a wall or surface
- Can be installed in combination with a 2-unit electrical box and can easily set or change the speaker orientation
- Finish: Base / Shaft: Stainless steel Bracket: Nickel-plated rolled steel plate

Specifications

Maximum Load Capacity	4 kg or less
Finish	Base, shaft: Stainless steel Bracket: Nickel-plated rolled steel plate
Weight	400 g
Included Accessories	Speaker mounting bracket.....2, Electric work box mounting screw.....4, Wall mounting screw.....4, Bracket fixing screw.....2

Note:

(1) Be sure to use the SP-410 in combination with TOA's speakers.

(2) Install the speaker indoors or under the eaves, where the speaker is not directly exposed to the rain, strong wind or vibration.

Dimensions

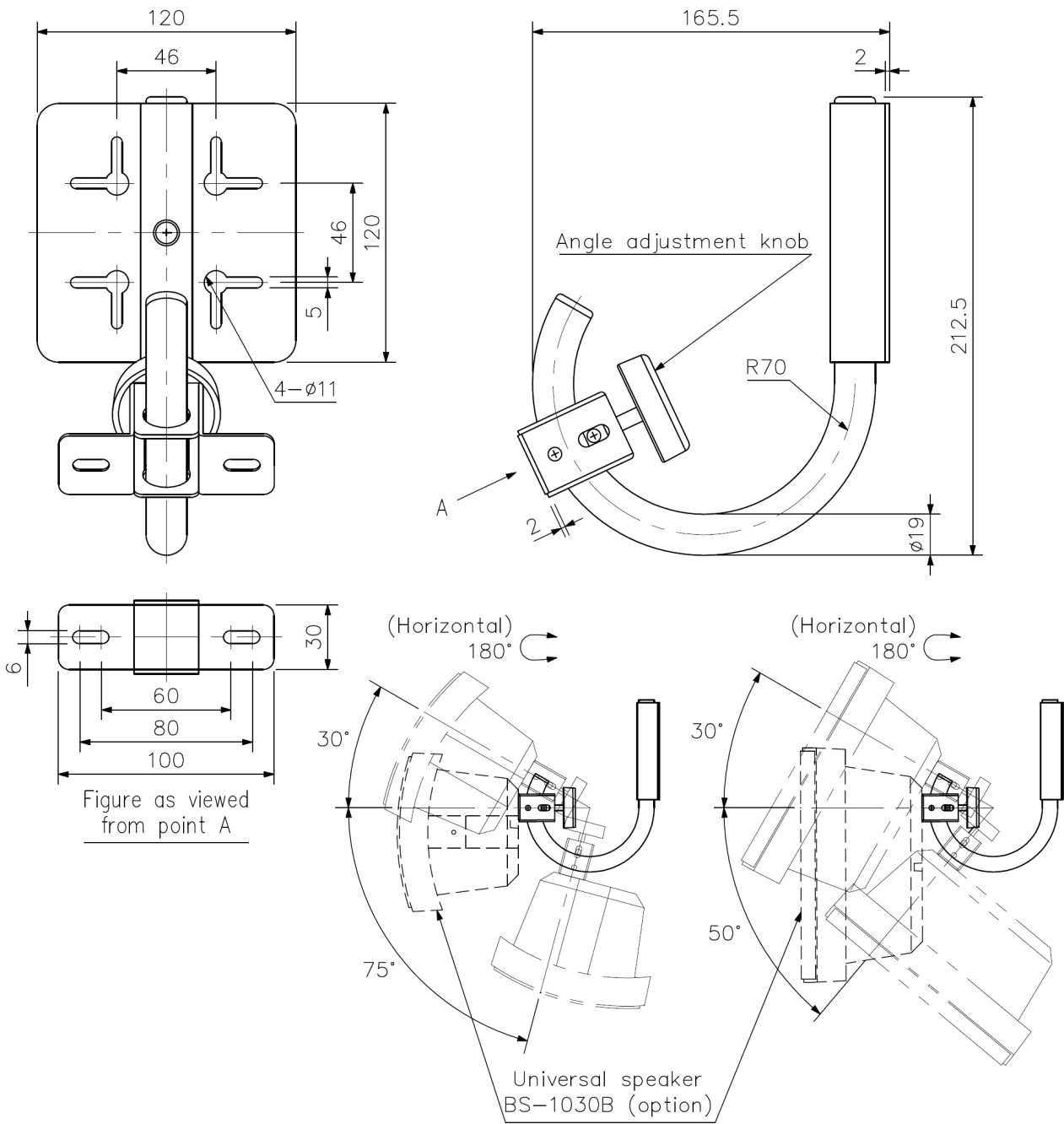

Figure as viewed from point A

Universal speaker BS-1030B (option)

Mounting example

To prevent the loss of splash-proof capabilities, do not install the speaker face-up when installing the BS-1030B, BS-1030W speaker outdoors.

UNIT:mm

A&E specifications

UNDEFINED TEXT