

## MB-WT3

### MOUNT BRACKET



The MB-WT3 is used to mount a one-unit size component that is 210 mm in width in an EIA Standard equipment rack.

### Key features

- For rack mounting of one wireless receiver unit to use with WT-5800/5805/4820 and/or IR-700D/702T

## Specifications

Finish	Bracket A and bracket B: Surface-treated steel plate, black, paint Stay and bracket stopper: Surface-treated steel plate, electrogalvanizing
Weight	510 g
Set Components	Bracket A .....1, Bracket B .....1, Stay .....1, Bracket stopper .....1
Included Accessories	Rack mounting screw ...4, Fiber washer ...4, Stay mounting screw ...1 set, Stay mounting washer ...1 set, Bracket stopper mounting screw ...1, Bracket stopper mounting washer ...1 set

## Dimensions

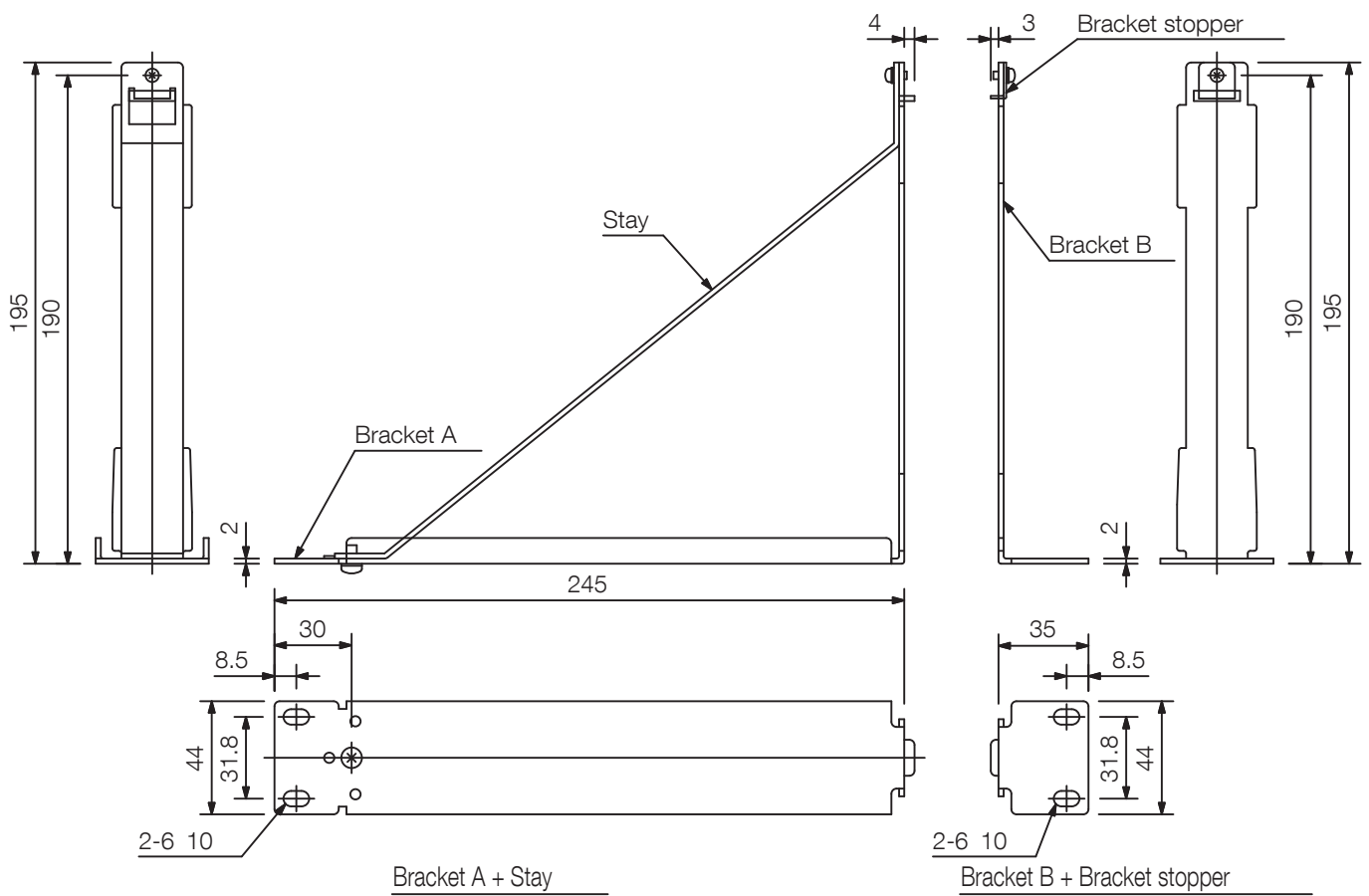

## Dimensions

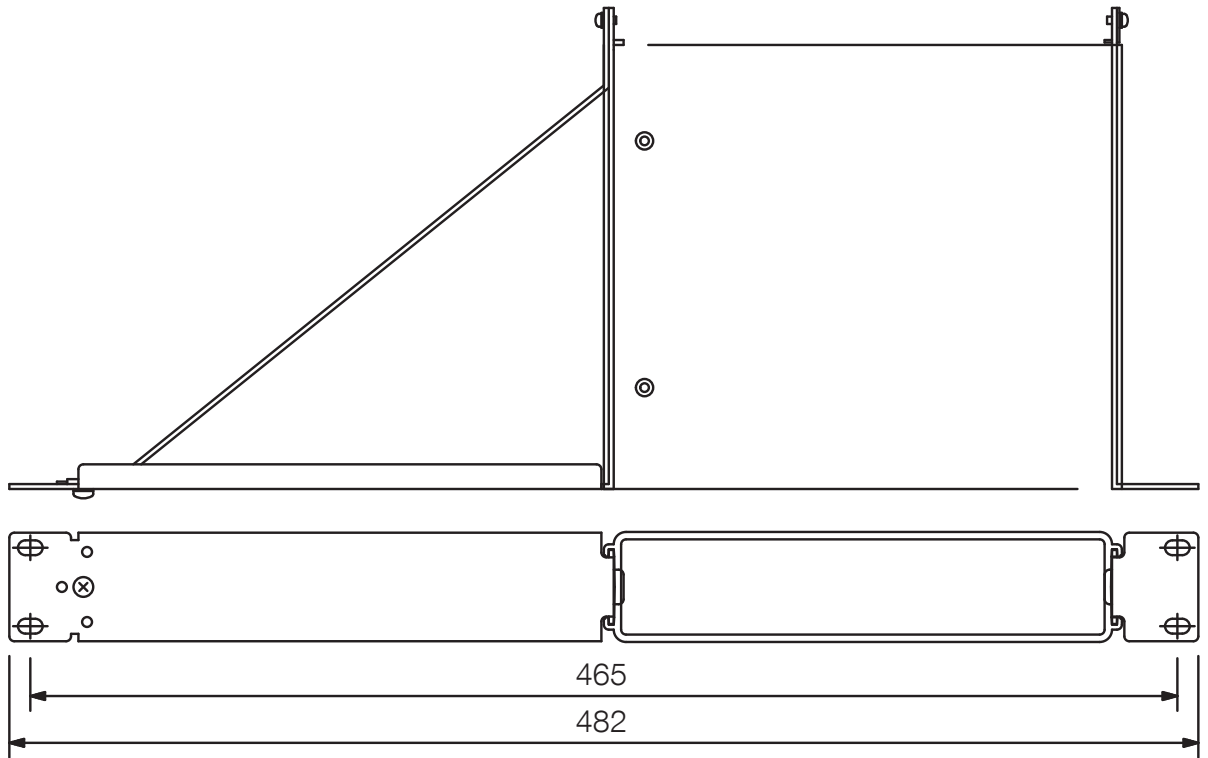

How to use joint brackets (scale: 1/4)

UNIT:mm

SCALE:1/3

## A&E specifications

19 Inch mounting kit with empty field for half x 19-inch units with one height unit, color: black