

## DA-250FH CU

### MULTICHANNEL POWER AMPLIFIERS



The DA-250FH is a 4-Channel Digital Power Amplifier designed for 70 V line high-impedance distribution and features lightweight, compact, high power output, and high efficiency. It delivers 250 W x 4 channels (19.6  $\Omega$  output) using a switching power supply. Each channel is equipped with an independent power section. It can be electrically isolated from the high-impedance speaker system by attaching the MT-251H Output Transformer (optional). It can be mounted in an EIA Standard equipment rack (1 unit size).

### Key features

- 4 x 250 W power output
- 70 V speaker output
- Low power consumption and light weight
- Each channel with independent power supply
- Control covers eliminate tampering
- Low-noise constant speed fans
- Stacking possible
- Protection circuitry
- Pulse width modulation with controlled power supply

## Specifications

\*0 dB = 0.775 V

Power Source	120 V AC, 50/60 Hz
Amplification System	Class D
Power Consumption	200 W (based on UL/CSA standards) 1200 W (rated output 70 V line, 19.6 $\Omega$ x 4)
Input	4 circuits, +4 dB* (1.23 V) (input level control in maximum position), 10 k $\Omega$ , electronically-balanced, removable terminal block (3 pins) CH 1 mode ON/OFF switch (ON: CH 1 to All ch, OFF: Each ch)
Rated Output	4 channels: 250 W x 4 (70 V line, 19.6 $\Omega$ ) 2 channels (BRIDGE): 500 W x 2 (140 V line, 39.2 $\Omega$ ) M4 screw terminal, distance between barriers: 8.8 mm
Frequency Response	20 - 20,000 Hz ( $\pm$ 1 dB): HPF OFF/50 - 20,000 Hz (-3 dB, +1 dB): HPF ON (selectable with the inner jumper)
Total Harmonic Distortion	0.1% (1 kHz), 0.3% (20 - 20,000Hz): HPF OFF 0.1% (1 kHz), 0.3% (100 - 20,000 Hz): HPF ON
Signal to Noise Ratio	100 dB (A-weighted)
Crosstalk	70 dB (A-weighted)
Protection Circuit	Protection against excessive current flow due to overload, short circuit, unusual DC voltage output, temperature rise at power amp. heat sink (110 $^{\circ}$ C or more), temperature rise inside the unit (80 $^{\circ}$ C or more)
LED Indicator	Power (blue) x 1, Input (green) x 4, Output (yellow) x 4, Peak (red) x 4, Protect (red) x 4
Cooling	Forced air cooling
Operating Temperature	-10 $^{\circ}$ C to +40 $^{\circ}$ C (14 $^{\circ}$ F to 104 $^{\circ}$ F)
Operating Humidity	90% RH or less (no condensation)
Finish	Panel: Aluminum, black, alumite Case: Plated steel sheet
Dimensions	482 (W) x 44 (H) x 401.8 (D) mm
Weight	6.6 kg
Included Accessories	Power cord (2 m) ...1, Removable terminal plug (3 pins) ...4, Tamper-proof cap ...4
Optional Accessories	Matching transformer: MT-251H

## Product rear image



## Dimensions

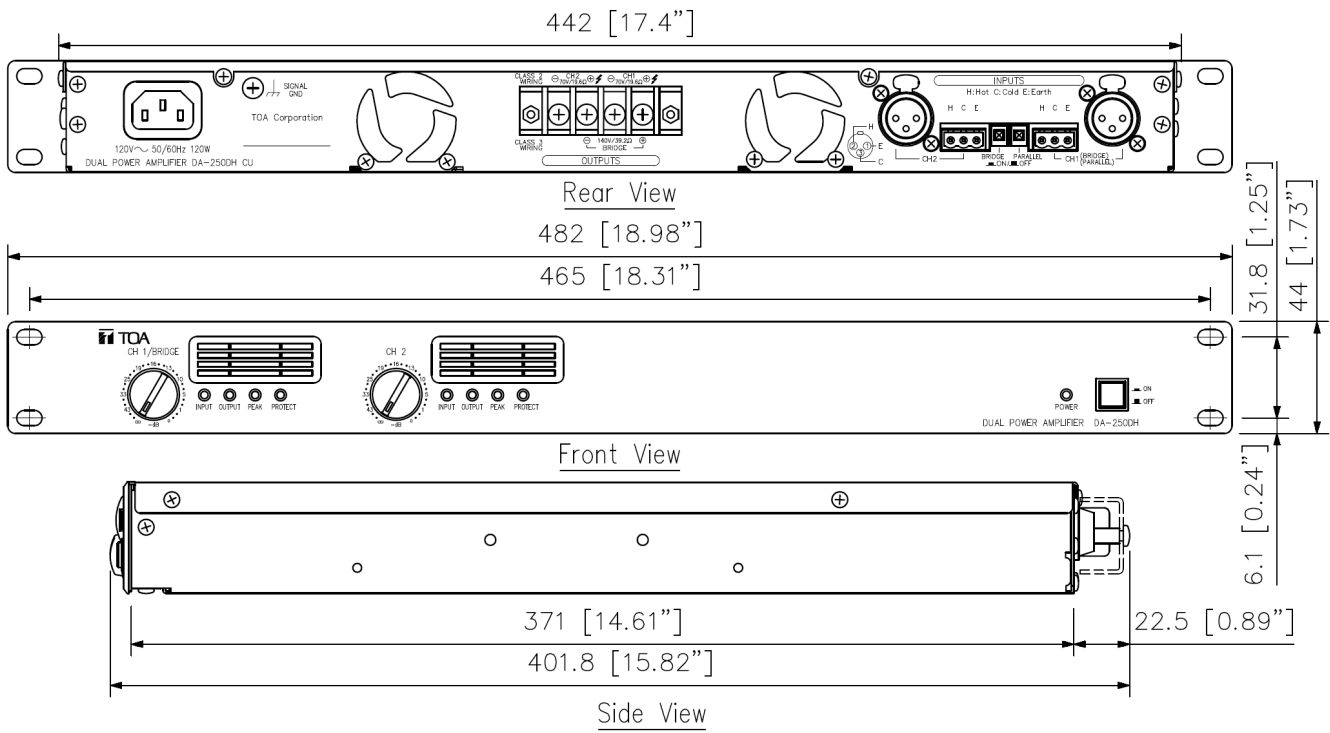

UNIT:mm

## A&E specifications

The multi-channel power amplifier shall use digital class-D circuit topology and shall be configurable to allow two, three or four channel operation.

Power output in four channel mode with all channels driven shall be: 250 watts per channel into 19.6 ohms (70.7 volts). Each pair of channels shall be independently bridgeable to produce 500 watts into 39.2 ohms (140 volts). Total harmonic distortion (THD) shall be less than 0.1% at 1 kHz and less than 0.3% from 20 to 20,000 Hz when High-pass filter is off. Frequency response shall be 20 to 20,000 Hz (+/-1 dB) when High-pass filter is off, 50 to 20,000 Hz (-3 dB, +1 dB) when High-pass filter is on. Hum and noise shall be 100 dB below rated output (A weighted). Crosstalk shall be better than 70 dB (A weighted). Input sensitivity shall be +4 or -10 dBv (jumper selectable) for rated output, where 0 dBv = 0.775 volts RMS. Input impedance shall be 10k ohms for each side of an electronically balanced input circuit. Rear-panel switches shall allow selection of bridged operation for each pair of channels (1-2 and 3-4) independent of the status of the other pair of channels. The amplifier shall operate in 4-channel mode when both switches are deselected, in 3-channel mode when either switch is selected, and 2-channel mode when both switches are selected. A rear-panel input mode switch shall allow the selection of "channel 1 to all" mode, whereby the signal feeding the channel 1 input terminals is simultaneously fed to all other channels. Rear panel input connector shall be a 3-pin removable terminal block for each channel. Rear panel output connector shall be a heavy-gauge M4 screw-terminal barrier strip suitable for spade lugs or up to #12 AWG bare wire. The front-panel attenuators shall be recessed to prevent accidental level changes and may be removed and replaced by included security covers once levels have been properly set. An internal jumper for each channel shall allow independent on/off selection of a 50 Hz high pass filter for protection against excessive low frequency loading and saturation of speaker transformers. The front panel shall have four sets of four LED indicators to indicate the following conditions for each channel: signal presence at input (greater than -20 dBv), signal presence at output (greater than 1 watt at 8 ohms), peak clipping, and protection circuit activation. The front panel shall also have removable air filters that may be cleaned and reinstalled without removing the amplifier from a rack. Built-in protection circuitry shall monitor Voltage and current levels to minimize potential damage from overloads, and disable output during shorts, DC offset, excessive operating temperature at power amp heat sink over 167°F (110°C) via a relay for each channel or excessive temperatures inside the unit over 176°F (80°C). The relay shall also delay amplifier connection to the load during turn-on for about 2 seconds, so as to prevent any concurrence of noise at turn-on. Power consumption shall be no more than 200 watts when all channels are driven with continuous pink noise at 1/8 full power into 19.6 ohms (UL/CSA standard), and no more than 1,200 watts when all channels are driven with continuous pink noise at full rated power into 19.6 ohms.

The amplifier shall use only one standard rack-space or 1.75" (44.5 mm) and its dimensions shall be 19" (482 mm) W x 15.8" (401.8 mm) D x 1.7" (44 mm) H. Front panel finish shall be black anodized aluminum and case finish shall be sheet steel. Weight shall be 14.6 lbs. (6.6 kg).

The amplifier shall be TOA model DA-250FH. The optional 1:1 line isolation transformer shall be TOA model MT-251H