

# PRODUCT ID: 32335

Alarm Unit

## MODEL

PA-WS-LV

## DIMENSIONS

1.41" H x 1.41" W x 1.7" D (est. 0.05 lbs)

## ELECTRICAL

Input Voltage:

# Product View

NOTE: Sign image may not exactly represent the finished product. For illustration purposes only.

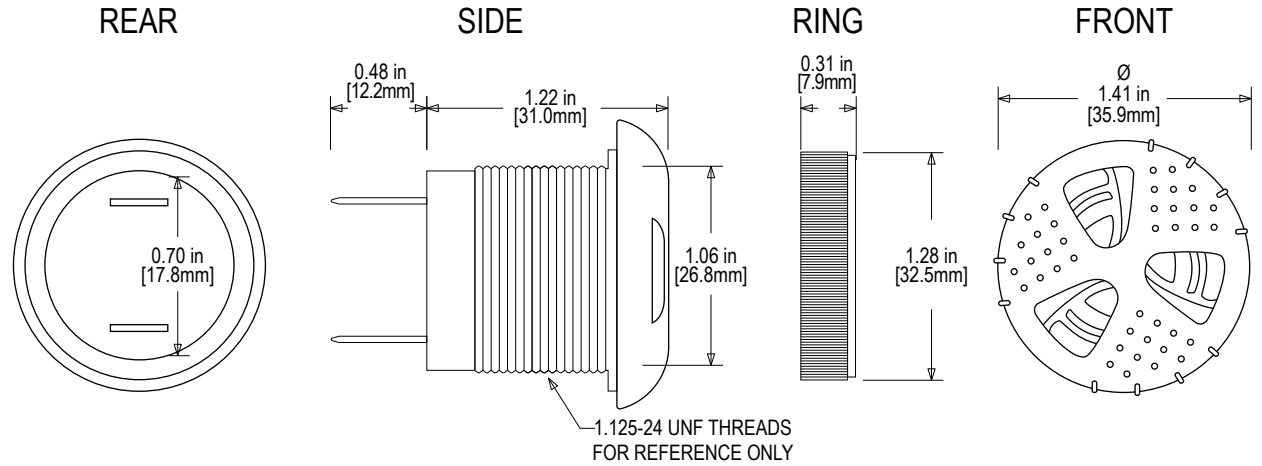

## "Q" TERMINALS

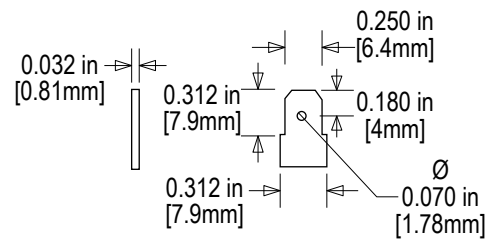

## PANEL MOUNTING

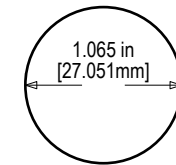

FITS PANELS UP TO 0.50in [12.7mm] THICK

TOLERANCES ARE ±0.03in [±0.76mm] UNLESS OTHERWISE SPECIFIED