

IP800-SERIES

INSERTION PADDLEWHEEL FLOW SENSOR



APPLICATIONS

Industrial water/wastewater treatment

Cooling water monitoring

Industrial fluid control

Chemical proportioning

Features

- Low-friction, long-life jewel bearings
- One moving part
- Fully field-repairable
- Choice of materials for compatibility with a variety of chemicals
- Fits 1/2" to 8" pipe
- Fixed depth in fitting ensures proper placement in pipe
- Data logger (optional)
- Sensus smart output (optional with display)

Contact Your Supplier

The **IP800-Series** are impeller (or "paddlewheel") insertion meters designed for use with a wide variety of clean liquids in pipe sizes 1/2" to 8". Sensors are available in brass, 316 stainless steel, PVC, and polypropylene. Bodies are machined from a solid rod for maximum precision. High-quality jewel bearings and nickel-bound tungsten carbide shafts are used for extreme low friction and long life.

The rotation of the rotor is detected by a non-drag Hall-effect sensor. Output is a current-sinking pulse, which can be sent long distances (up to 2,000 feet) without a transmitter. This signal can be connected directly to PLC's, counters, and computer cards, as well as a variety of Seametrics controls and displays.

For rate and total display, a modular system of electronics can be installed directly on the flow sensor or mounted remotely. The FT430 (externally powered with pulse), FT440 (loop powered), and FT450 (battery powered) all provide digital rate and total displays, as well as a programmable pulse; the FT440 also provides a 4-20 mA analog output. Electronic modules can be wall- or meter- mounted. If no display is required, a simple divider may be needed, such as the PD10 to provide adjustable pump pacing.

The IP800-Series require special fittings that ensure correct depth placement in the pipe. Fittings come in a variety of materials for compatibility with specific applications. Tee fittings are individually wet-calibrated at the factory and marked with the K-factor (pulses per gallon). Saddle fittings must be field-installed on the pipe and do not come wet-calibrated. K-factors for saddles are based on factory-testing.



IP800-SERIES INSERTION PADDLEWHEEL FLOW SENSOR



Features

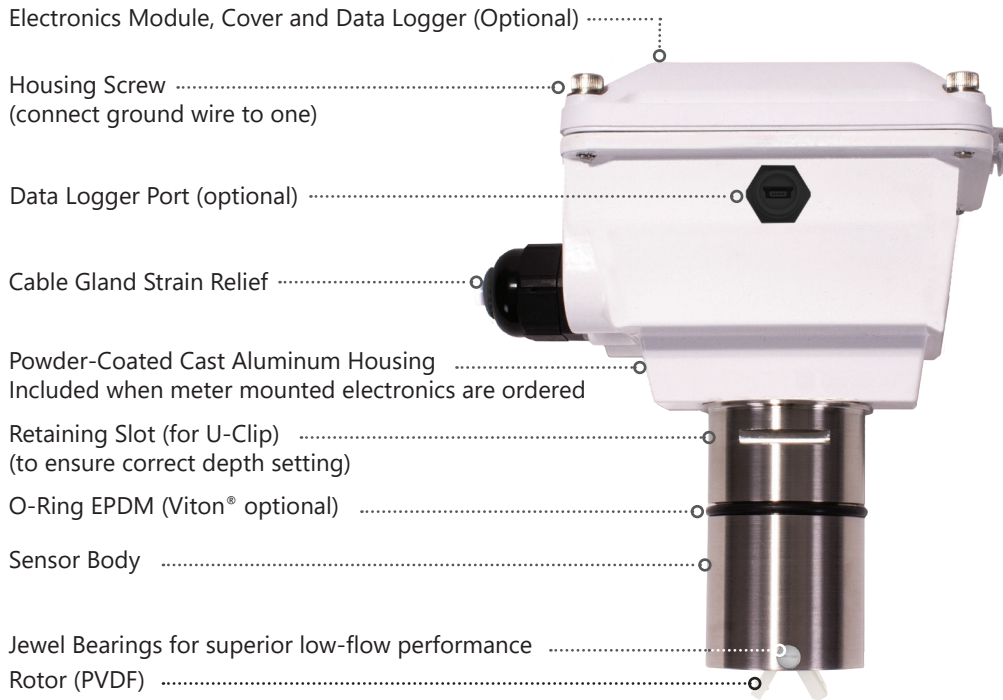

High Pressure Tee Fitting



Specifications*

Pipe Size	1/2" to 8"			
Power	Low Power: 6-36 Vdc/< 2 mA	Micropowered (-04 Option): 3.1-16 Vdc/60 µA @ 3.6 Vdc		
Sensor	Low Power: Digital Magnetoresistive	Micropowered (-04 Option): Giant Magnetoresistance (GMR)		
Materials	Optional Housing	Powder-coated cast aluminum		
	Sensor Body	Brass, 316 Stainless Steel, PVC, or Polypropylene		
	O-ring	EPDM (Viton® optional)		
	Rotor	PVDF (Kynar®)		
	Shaft	Kynar® /Tungsten Carbide (Kynar® /Ceramic or Kynar® /Silicon Carbide optional)		
	Bearings	Ruby jewel		
Maximum	Brass	316 Stainless Steel	PVC or Polypropylene (See Pressure vs. Temp. Chart)	
	Pressure	200 psi (14 bar)	200 psi (14 bar)	175 psi (12 bar) @ 75° F (24° C)
	High Pressure	Not available	400 psi (28 bar)	Not available
	Temperature	200° F (93° C)	200° F (93° C)	130° F (55° C)
Flow Velocity	0.3 to 30 ft/sec (0.09 to 9.14 m/sec)			
Accuracy	± 1.5% of full scale			
Output Transistor Maximum Current Sinking	150mA (low power version only)			
Cable	#22 AWG 3-con, 18' (6m); 2,000' (610m) maximum cable run Note: 50' (15m) maximum for battery powered or micropowered versions.			
Environmental	See meter mounted electronics specification for rating			
Regulatory	CE Mark			

*Specifications subject to change • Please consult our website for current data (www.seametrics.com).
 Kynar is a registered trademark of Arkema, Inc., Viton is a registered trademark of DuPont Corporation.

Flow Range

Nominal Pipe Size	1/2"	3/4"	1"	1 1/2"	2"	3"	4"	6"	8"
Min GPM	0.28	0.5	0.8	1.9	3.1	6.9	12	27	46.8
Min LPM	1.06	1.89	3.03	7.2	11.7	26.1	45	102	177
Max GPM	28	50	80	190	314	691	1190	2700	4680
Max LPM	106	189	302	719	1188	2615	4504	10221	17716

Dimensions

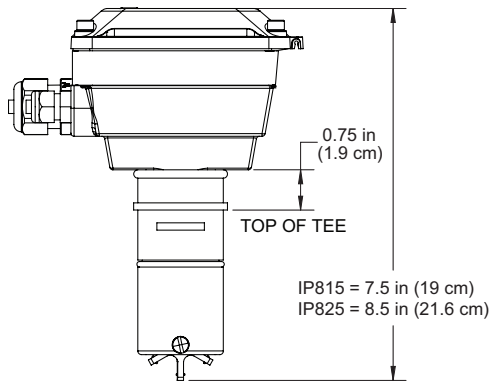

NOTE:
 Housing Optional

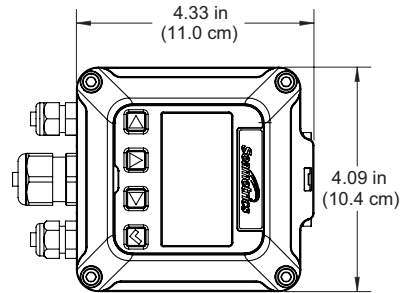

Available Fittings

	Tee	Saddle	Weldolet	Sweat Tee
Bronze	1/2" - 4"	3" - 4"	3" - 8"*	1/2" - 4"
PVC	1/2" - 2"	3" - 8"	x	x
Stainless Steel	1/2" - 2" 304SS	x	3" - 8" 316SS	x
Carbon Steel	1/2" - 2"	x	3" - 8"	x
Ductile Iron	x	3" - 8"	x	x

* Brass

Pressure vs. Temperature (PVC/Polypro)

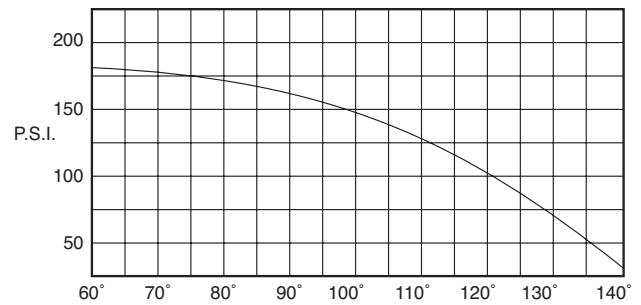

PVC Block Tee Fitting (Figure 1)

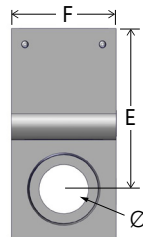
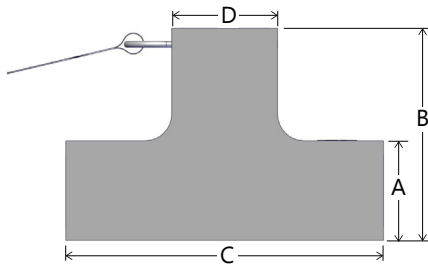

PVC Tee Fittings (Figure 2)

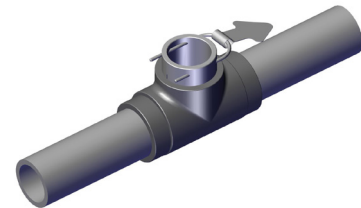
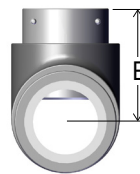
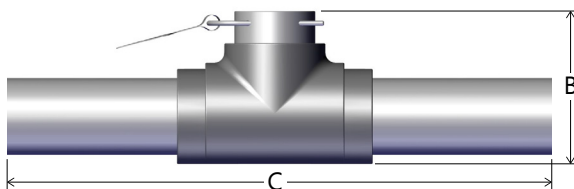

Figure	Pipe Size	A	B	C	D	E	F	Ø
1	1/2"	1.50" (3.81 cm)	3.80" (9.65 cm)	6.00" (15.24 cm)	2.00" (5.08 cm)	3.15" (8.00 cm)	2.00" (5.08 cm)	0.83" (2.11 cm)
1	3/4"	1.90" (4.83 cm)	4.00" (10.16 cm)	6.00" (15.24 cm)	2.00" (5.08 cm)	3.05" (7.75 cm)	2.00" (5.08 cm)	1.06" (2.69 cm)
1	1"	1.88" (4.77 cm)	4.00" (10.16 cm)	6.00" (15.24 cm)	2.00" (5.08 cm)	3.06" (7.77 cm)	2.00" (5.08 cm)	1.325" (3.36 cm)
2	1 1/2"	—	4.50" (11.43 cm)	19.4" (49.28 cm) <i>(nominal)</i>	—	3.35" (8.51 cm)	—	—
2	2"	—	4.90" (12.45 cm)	19.9" (50.55 cm) <i>(nominal)</i>	—	3.45" (8.76 cm)	—	—

How to Order

	Description	Size	Sensor Material	Options
Sensor Only	Sensor Only.	1/2" - 3" = IP810 4" - 8" = IP820	Brass = B 316 Stainless Steel = S PVC = P Polypro = Y	Rotor with Ceramic Shaft, PVDF, Kynar® = -01 Micropower Pickup (Required for use with FT450) = -04 Standard Power, LMI 4-pin Connector = -06 Standard Power, Seametrics Control Connector = -07 *Immersible = -40 Viton® O-Ring = -60 Rotor with Kynar®/Silicon Carbide Shaft = -68 Roytronic® Series A Pump 5-pin Connector = -106 **High Pressure (Stainless Only) = -HP
FT430 Mounted on Sensor	Rate & total indicator with pulse, externally powered (FT430) mounted on the sensor.	1/2" - 3" = IP813 4" - 8" = IP823	Brass = B 316 Stainless Steel = S PVC = P Polypro = Y	Rotor with Ceramic Shaft, PVDF, Kynar® = -01 Tamper Evident Kit = -32 Viton® O-Ring = -60 Non-resettable Total = -64 Rotor with Kynar®/Silicon Carbide Shaft = -68 Dual Relay Output = -98 Hinged Display Cover = -126 **High Pressure (Stainless Only) = -HP Internal Data Logger = -127 Sensus Smart Output (Includes 6' Cable) = -150
FT450 Mounted on Sensor	Rate & total indicator with pulse, externally powered (FT450) mounted on the sensor.	1/2" - 3" = IP817 4" - 8" = IP827	Brass = B 316 Stainless Steel = S PVC = P Polypro = Y	Rotor with Ceramic Shaft, PVDF, Kynar® = -01 Tamper Evident Kit = -32 Viton® O-Ring = -60 Non-resettable Total = -64 Rotor with Kynar®/Silicon Carbide Shaft = -68 Hinged Display Cover = -126 **High Pressure (Stainless Only) = -HP Internal Data Logger = -127 Sensus Smart Output (Includes 6' Cable) = -150
FT440 Mounted on Sensor	Rate & total indicator with pulse & 4-20 mA output, loop powered (FT440) mounted on the sensor.	1/2" - 3" = IP819 4" - 8" = IP829	Brass = B 316 Stainless Steel = S PVC = P Polypro = Y	Rotor with Ceramic Shaft, PVDF, Kynar® = -01 Tamper Evident Kit = -32 Viton® O-Ring = -60 Non-resettable Total = -64 Rotor with Kynar®/Silicon Carbide Shaft = -68 Dual Relay Output = -98 Hinged Display Cover = -126 **High Pressure (Stainless Only) = -HP Internal Data Logger = -127 Sensus Smart Output (Includes 6' Cable) = -150

* Immersible to maximum of 3 ft (1m), up to 2 weeks

**Requires appropriate fitting.

Kynar is a registered trademark of Arkema, Inc. Roytronic is a registered trademark of Milton Roy Company. Viton is a registered trademark of DuPont Corporation.

User is responsible for reviewing end use application with their supplier for product suitability.