



Dual O₂/CO₂ Monitor, 0-25% and 0-10,000 ppm

ITEM #: 99039-Includes Domestic Power Supply
ITEM#: 99122-Optional Remote CO₂ Cable. Domestic Power Supply
ITEM#: 99139-Includes International Power Supply
ITEM#: 99176-Optional Remote CO₂ Cable. Int'l. Power Supply

Product Summary

PureAir Monitoring Systems Dual Oxygen/Carbon Dioxide Monitor is designed for continuous monitoring of oxygen and carbon dioxide in confined spaces. The monitor is ideal for facilities that use inert gases including, but not limited to, nitrogen, helium, carbon dioxide, and argon. The dual O₂/CO₂ monitor is suitable for environments such as cryogenic facilities, breweries, food processing plants, laboratories, hospitals, and universities. The monitor will remain accurate at temperatures as low as -40C. PureAir's durable, non-depleting, zirconium oxide sensor cell and non-dispersive infrared sensor (NDIR) cell, will last 10+years in a normal environment, without needing to be replaced.

Facilities That Need This Product

- *Pharmaceutical Manufacturers*
- *Hospitals*
- *Breweries*
- *Cryogenic Facilities*
- *Universities*
- *Food Processing*

FEATURES

- No scheduled maintenance zirconium O₂ cell and long life CO₂ sensor
- No calibration required for oxygen
- Self-calibrating CO₂ sensor
- Local backlit concentration display
- Built-in audible horn
- Built-in visual LED alarm indicators
- Alarm level 1 for CO₂ and Alarm level 2 for O₂
- No drift due to environmental or temperature changes
- 3-year warranty
- Optional remote cable for monitoring CO₂ up to 10 feet from the transmitter
- 24V DC Power Supply Included(99039, 99122)
- International Power Supply Included(99139, 99176)

Why choose PureAir?

PureAir Monitoring Systems, Inc. is an industry leader in oxygen and gas detection. For over 25 years, we have dedicated ourselves to the safety of our clients, and the customers they serve, by manufacturing monitors that are long-lasting, accurate, and reliable. PureAir takes pride in providing exceptional customer service, along with 24/7 availability to our technical service department.

Why a Dual O₂/CO₂ Monitor?

The dual O₂/CO₂ monitor is designed for continuous monitoring in confined spaces where low oxygen levels and high carbon dioxide levels pose a hazard to personnel.

What gases can be detected with a Dual O₂/CO₂ Monitor?

PureAir's Dual O₂/CO₂ Monitor can be used to monitor CO₂, nitrogen, argon, and helium gases.

Easy to Use

The monitor will arrive ready to work right out of the box. Simply secure the unit to the wall 3-5 feet from the gas source, plug it in, and power it on. The optional remote cable allows for CO₂ monitoring up to 30 feet from the transmitter. The monitor will begin sampling O₂/CO₂ levels after a brief startup period. Oxygen/Carbon Dioxide levels are displayed clearly on the screen for easy access and visibility.

Top Advantages of Dual O2/CO2 Monitor



Dual O2/CO2 Monitor Alarm Features

PureAire's Dual O2/CO2 Monitor has 2 adjustable alarm relay setpoints that can connect to a horn/strobe, 8 channel controller, remote display, or into building systems. Alarm signals also can tie into automatic shut-off valves when oxygen levels fall below the OSHA threshold.



Easy To Use

PureAire's Dual O2/CO2 Monitor provides constant monitoring with little to no adjustments, saving you time and money while allowing the monitor to operate seamlessly. Our quality sensors make this the longest lasting monitor on the market.

99039 - Dual O2/CO2

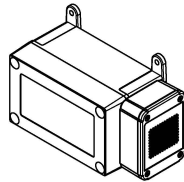
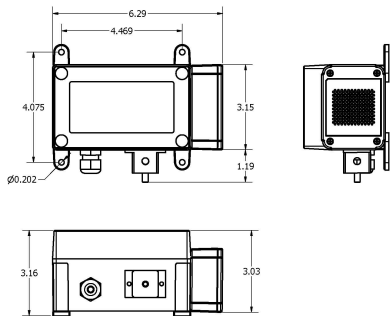

99122 - Optional Remote CO2

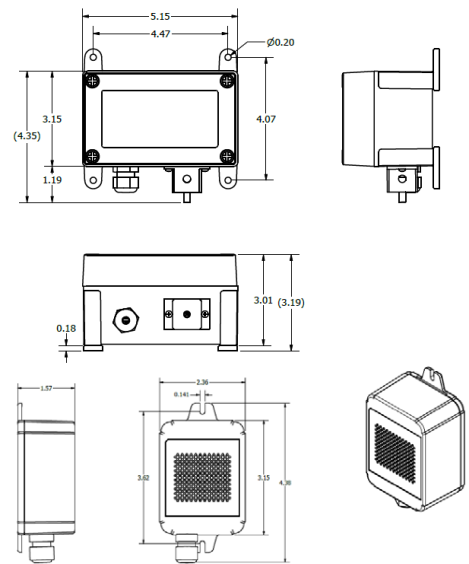

Top Accessories



**8 Channel Programmable
Controller for O2 or Gas
Monitors**
ITEM #: 99196



**Remote Digital
Display**
ITEM #: 99183



**Red Horn/Strobe
24VDC**
ITEM #: 42002



1-888-788-8050

info@pureaire.net
pureairemonitoring.com

1140 Ensell Road
Lake Zurich, IL 60047
1-847-726-6000