



PM-25/PM-25S

Vocal Microphone



USER MANUAL

IMPORTANT SAFETY INSTRUCTIONS

1. Read and follow these instructions carefully.
2. Use only attachments, accessories, and spare parts specified by the manufacturer.
3. Avoid exposing the microphone to liquids, excessive humidity, or conductive objects that could affect its performance.
4. Keep the microphone away from high-temperature sources, such as open flames, radiators, or direct sunlight, to prevent damage.
5. Avoid stepping on, pulling, or bending the microphone cable to prevent internal damage and ensure longevity.
6. When connecting or disconnecting the microphone, lower the volume of your audio equipment to avoid loud noise or potential damage to speakers.
7. Store the microphone in a dry, dust-free environment when not in use for an extended period.
8. If using the microphone with phantom-powered devices, ensure compatibility and proper setup to avoid potential issues.
9. Do not modify the microphone or its components. Unauthorized modifications may result in performance degradation or void the warranty.
10. Dispose of electronic components responsibly. Follow local regulations for electronic waste recycling.



Caution: This symbol means the product must not be discarded as household waste, and should be delivered to an appropriate collection facility for recycling. Proper disposal and recycling helps protect natural resources, human health and environment. For more information on disposal and recycling of this product, contact your local municipality, disposal service, or shop where you bought this product.

EU Directives



This product meets the Essential Requirement of all relevant European directives and is eligible for CE marking.

Meets essential requirements of the following European Directives:

WEEE Directive 2019/19/EU

RoHS Directive EU 2015/863

Note: Please follow your regional recycling scheme for batteries and electronic waste

Authorized European Representative



APEX CE SPECIALISTS LIMITED

6F East Union Street, Manchester, England, M16 9AE

United Kingdom

Email: info@apex-ce.com



APEX CE SPECIALISTS GmbH

Grafenberger Allee 277, 40237 Düsseldorf, Germany

Email: info@apex-ce.com

*Thank you for purchasing the Phenyx Pro PM-25/PM25S Vocal Microphone.
For the best results and the utmost satisfaction for your new unit,
please read this manual carefully to ensure proper operation,
and keep it for future reference. For more information,
please visit our store: www.phenyxpro.com*

Table of Contents

System Description.....	5
Overview.....	5
Features.....	5
Components.....	5
Design.....	6
Usage Tips.....	6
Specification.....	6
Technical Support & Warranty Information.....	7

System Description

Overview

The Phenyx Pro PM-25/PM-25S dynamic microphone delivers balanced, full-bodied, and bright vocals with ease of drive, requiring less gain for strong output. Its cardioid pickup pattern minimizes background noise and enhances precision in vocal capture. A wide dynamic range allows it to handle high SPL environments without distortion. The durable all-metal construction withstands physical impact for long-term reliability. With solid sound quality and robust build, it is ideal for live performances, speeches, studio recordings and other professional audio applications.

Features

- Specially tuned frequency response delivers balanced, full-bodied, and bright vocals.
- High output with lower gain requirements for clear and powerful sound.
- Wide dynamic range preserves subtle vocal details while preventing distortion in high SPL environments.
- Cardioid pickup pattern minimizes background noise for precise and focused vocal capture.
- Built-in foam filter reduces unwanted breath and wind noise for cleaner sound.
- Anti-rolling grille prevents accidental slips that may lead to damage.
- All-metal construction resists external impact for long-term reliability.
- The on/off switch on the PM-25S allows quick muting and helps avoid unwanted noise.
- Included mic clip, compatible cable, storage pouch, and cable tie provide added convenience.

Components

1 x PM-25/PM-25S microphone
1 x Microphone clip
1 x 5 m (16.4 ft) XLR cable
1 x Faux leather storage pouch
1 x Hook-and-loop cable tie

Design

PM-25

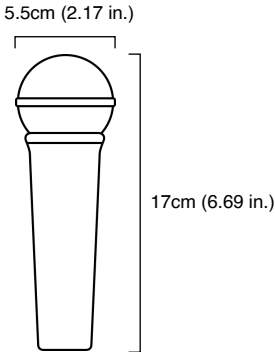

PM-25S

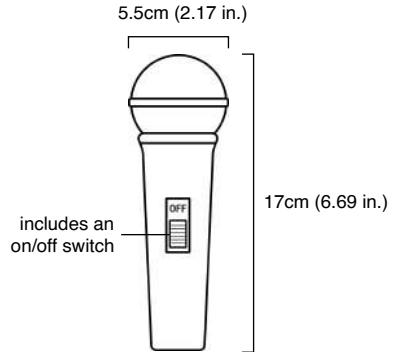

Usage Tips

- Keep proper distance (2-4 inches) from your mouth for clear sound.
- Grip the handle, not the grille, to avoid muffling.
- Reduce plosive sounds by tilting the mic off-center.
- Keep the mic away from speakers and monitors to avoid feedback.
- Start with low gain and gradually increase to achieve a balanced sound.

Specification

Microphone Type	Dynamic microphone
Connector	XLR
Polar Pattern	Cardioid
Frequency Response	40Hz – 15kHz
Sensitivity	-50 ± 2dB (0dB = 1V/Pa)
Output Impedance	260Ω ± 15% at 1kHz
Dimension	5.5cm x 17cm (2.17 in. x 6.69 in.)
Weight	0.275kg (0.61 lbs)

Technical Support & Warranty Information

Our warranty to you:

Phenyx Technology ("Phenyx") warrants Phenyx products against evident defects in material and workmanship for a period of one year from the date of original purchase for use. This warranty is valid exclusively in the US and applies only to the original owner. If you discover a defect covered by this warranty, Phenyx will repair or replace the product at our sole discretion using new or refurbished components. Performance of repairs or replacements under this warranty is subject to registration of your product at www.phenyxpro.com

Product failures not covered by this warranty:

This warranty covers defects in manufacturing that arise from the correct use of the device. It is limited to defects in materials or workmanship and does not cover electrical or mechanical damage resulting from abuse, misuse, unauthorized modification, lack of reasonable care, extreme heat, cold, damage due to natural forces, or corrosive environments. This warranty does not cover the normal wear and tear on covers, housing, connectors, and accessories.

Limits of liability:

If your Phenyx product fails or does not perform as warranted, your sole recourse shall be to replace or repair it as described above. Phenyx will not be liable to you or anyone else for any damages that result from the failure of this product. These damages include, but are not limited to, the following: lost profits, lost savings, lost data, damage to other equipment, and incidental or consequential damages arising from the use of or inability to use this product. IN NO EVENT PHENYX SHALL BE LIABLE FOR MORE THAN THE AMOUNT OF YOUR PURCHASE PRICE, NOT TO EXCEED THE CURRENT LIST PRICE OF THE PRODUCT.

How to obtain service under this warranty:

If you are receiving a system that is defective or you have any questions regarding operation or warranty cover, please contact us at support@phenyxpro.com with any questions or concerns and a Phenyx Pro representative will contact you to provide assistance. You can also reach out to us through Facebook page: www.facebook.com/phenyxusa/ or our official website: www.phenyxpro.com.



www.phenyxpro.com

Made in China

Manufacturer: Guangzhou VILAN Technology CO., LTD.

Address: No.101 Wanggangdexing Road, Baiyun District, Guangzhou, China

After-sales Service E-mail: support@phenyxpro.com ; info@phenyxpro.com