RHT *Climate* Transmitter

WM and DM models

USER GUIDE V1.4x F



Applies to devices with firmware version starting with V1.4x.



1	SAFETY ALERTS.....	4
2	INTRODUCTION.....	5
3	IDENTIFICATION.....	6
3.1	MODELS WITHOUT DISPLAY.....	6
3.2	MODELS WITH DISPLAY.....	6
3.3	DEVICE MODELS.....	7
4	DISPLAY INDICATIONS.....	8
4.1	HOME SCREEN.....	8
4.2	DISPLAYING MAXIMUM AND MINIMUM VALUES.....	8
4.3	DISPLAYING OTHER PSYCHROMETRIC PROPERTIES.....	9
4.4	SIGNALS.....	9
5	INSTALLATION.....	10
5.1	MECHANICAL INSTALLATION.....	10
5.1.1	RHT <i>Climate</i> WM.....	10
5.1.2	RHT <i>Climate</i> DM.....	10
5.1.3	DIMENSIONS.....	11
5.1.3.1	RHT <i>Climate</i> TRANSMITTER – WM MODEL.....	11
5.1.3.2	RHT <i>Climate</i> TRANSMITTER – DM MODEL.....	11
5.1.4	REMOVING AND INSTALLING THE FRONT COVER.....	13
5.2	TYPES OF TIPS.....	13
5.2.1	INSTALLATION.....	13
5.3	ELECTRICAL INSTALLATION.....	14
5.3.1	INSTALLATION RECOMMENDATIONS.....	14
5.3.2	SPECIAL PRECAUTION.....	14
5.3.3	ELECTRICAL CONNECTIONS.....	14
5.3.4	USB CONNECTION.....	14
5.4	SENSOR MAINTENANCE.....	15
5.4.1	PRECAUTIONS WITH SENSORS.....	15
5.4.2	SENSOR REPLACEMENT.....	15
6	PARAMETER CYCLES.....	17
7	CONFIGURATION.....	18
7.1	ANALOG OUTPUTS <i>Qut1 / Qut2</i>	18
7.2	ALARM OUTPUTS <i>RL1 / RL2</i>	20
7.3	BUZZER CONFIGURATION CYCLE.....	23
7.4	HMI CONFIGURATION CYCLE.....	25
7.5	DIAGNOSTIC CYCLE.....	27
7.6	COMMUNICATION CYCLE.....	28
7.7	GENERAL CONFIGURATION CYCLE.....	29
7.8	INFORMATION CYCLE.....	31
8	PARAMETERS MAP.....	32
9	COMMUNICATION INTERFACES.....	33
9.1	CONNECTING TO A COMPUTER.....	33
9.2	CONNECTING TO ANDROID SMARTPHONE.....	33
9.2.1	CONNECTION VIA OTG CABLE.....	33
9.2.2	CONNECTION VIA MODBUS-TCP PROTOCOL.....	33
9.3	CONNECTING TO IOS SMARTPHONE.....	34
10	SERIAL COMMUNICATION.....	35
10.1	HOLDING REGISTER TABLE.....	35
11	SIGNOW SOFTWARE AND APP.....	41
11.1	SIGNOW SOFTWARE.....	41
11.2	SIGNOW APP.....	41
11.3	STARTING SIGNOW.....	41
11.4	CONNECTING TO THE SOFTWARE.....	42
11.5	CONNECTING TO THE APP VIA OTG CABLE.....	43
11.6	CONNECTING TO THE APP VIA MODBUS-TCP PROTOCOL.....	44
11.7	CONFIGURING THE DEVICE.....	45

11.7.1	GENERAL / BASIC.....	45
11.7.2	COMMUNICATION.....	45
11.7.3	TEMPERATURE.....	46
11.7.4	RELATIVE HUMIDITY	46
11.7.5	OUTPUTS 1 AND 2.....	47
11.7.6	ALARMS 1 AND 2	47
11.7.7	HMI	48
11.7.8	DIAGRAM	49
11.7.9	FIRMWARE UPDATE.....	50
11.8	PERFORMING THE DIAGNOSTICS	51
12	TECHNICAL SPECIFICATIONS	53
13	WARRANTY	55
14	APPENDIX 1 – NOTIONS ABOUT PSYCHROMETRY	56
14.1	DRY BULB TEMPERATURE [°C] OR [°F].....	56
14.2	RELATIVE HUMIDITY [%RH].....	56
14.3	DEW POINT TEMPERATURE [°C] OR [°F]	56
14.4	WET BULB TEMPERATURE [°C] OR [°F]	56
14.5	ABSOLUTE HUMIDITY [G/M ³] OR [GR/FT ³].....	56
14.6	FROST POINT TEMPERATURE [°C] OR [°F]	56
14.7	SPECIFIC ENTHALPY [KJ/KG] OR [BTU/LB].....	56
14.8	PARTIAL VAPOR PRESSURE [MBAR] OR [PSI].....	56
14.9	MIXTURE RATIO [G/KG] OR [GR/LB]	56

1 SAFETY ALERTS

The symbols below are used in the device and throughout this manual to draw the user's attention to valuable information related to device safety and use.

		
CAUTION Read the manual fully before installing and operating the device.	CAUTION OR HAZARD Risk of electric shock.	ATTENTION Material sensitive to static charge. Check precautions before handling.

All safety recommendations appearing in this manual must be followed to ensure personal safety and prevent damage to the instrument or system. If the instrument is used in a manner other than that specified in this manual, the device's safety protections may not be effective.

2 INTRODUCTION

RHT *Climate* Transmitters Wall Mount (**WM**) and Duct Mount (**DM**) models have high-precision, stable sensors for measuring temperature and relative humidity. Being micro processed devices, they allow full configuration via USB or RS485 interface via a Modbus RTU command.

SigNow configuration software or app allows you to configure the features of the device, as well as perform diagnostics on the analyzed information.

Apart from the **temperature** and **relative humidity** values, which are read directly from the sensor, the transmitter calculates the value of the following psychrometric properties¹:

- Dew Point Temperature
- Wet Bulb Temperature
- Absolute Humidity
- Frost Point Temperature
- Specific Enthalpy
- Partial Vapor Pressure
- Mixture Ratio

Any variable read by the sensor or calculated by the device can be transmitted via one of the two available analog outputs. You are also allowed to configure the electrical operating level of each output:

- 0-10 V
- 4-20 mA

Two digital outputs with alarm or control functions can be related to any variable read or calculated by **RHT *Climate* Transmitter**.

The following options are also available:

- RS485
- Display with Backlight
- Audible signal

It is important that you read the manual before using this device and check that the versions of the manual and the device match. The firmware version number is displayed at the moment the device is powered on.

¹ Psychrometry is the study of thermodynamic properties of dry air and water vapor mixtures. Obtaining the psychrometric properties is crucial in the psychrometric processes of air conditioning, refrigeration, cooling and freezing, air humidification and dehumidification, drying and dehydration of humid devices, as well as in environmental and meteorological control.

3 IDENTIFICATION

3.1 MODELS WITHOUT DISPLAY

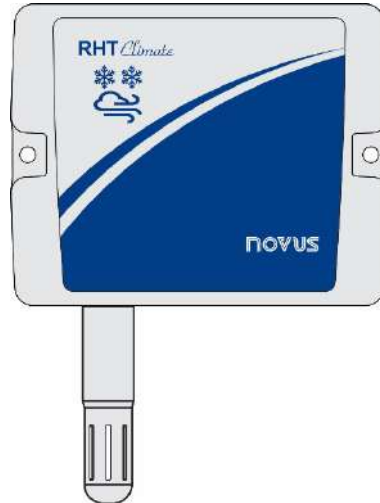

Figure 1

3.2 MODELS WITH DISPLAY

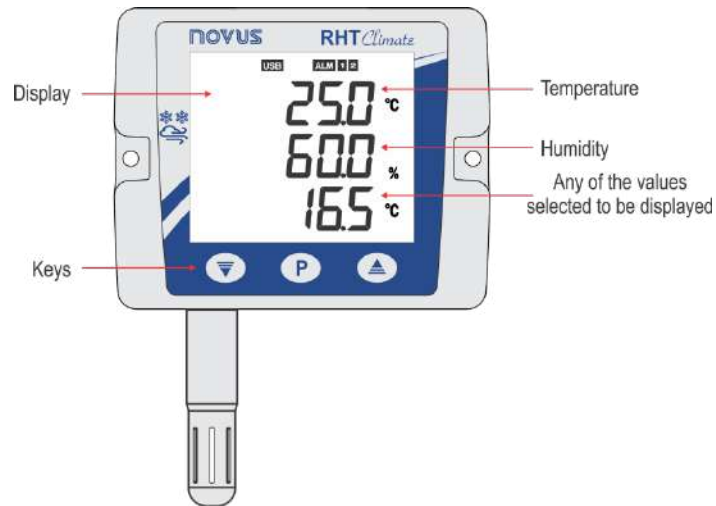

Figure 2

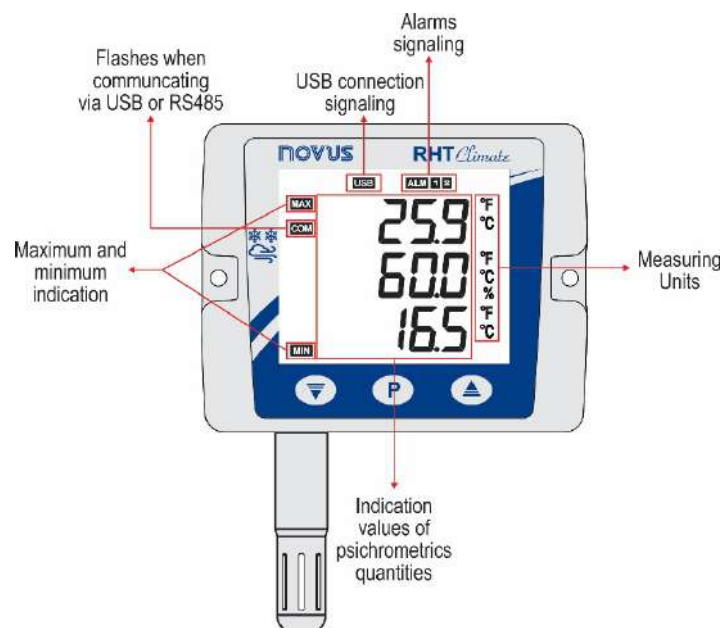





Figure 3

Key  : Key used to advance the parameters and parameters cycles. A short touch advances parameters within a cycle. A long touch advances parameters cycle.

Key  : Key used to decrease parameters. A long touch when displaying the home screen performs the action linked to the second function of the key:

- None.
- Clears registered minimum and maximum values.

Key  : Key used to increase parameters. A long touch when displaying the home screen performs the action linked to the second function of the key:

- None.
- Mutes the buzzer.
- Mutes the buzzer and turns off the alarm outputs.

3.3 DEVICE MODELS

The RHT *Climate* Transmitter line is available in various configurations:

- **Wall Mount Model (WM)**: Recommended for wall mounting.
- **Duct Mount Model (DM)**: Recommended for duct mounting. DM models are available with a stainless steel (S) sensor probe and with lengths of 150 mm, 250 mm, or 400 mm.

The table below shows all available models:

MODEL	RS485	DISPLAY	STAINLESS STEEL PROBE
RHT Climate-WM-485-LCD	✓	✓	
RHT Climate-WM-485	✓		
RHT Climate-DM-150S-485	✓		150 mm
RHT Climate-DM-150S-485-LCD	✓	✓	150 mm
RHT Climate-DM-250S-485	✓		250 mm
RHT Climate-DM-250S-485-LCD	✓	✓	250 mm
RHT Climate-DM-400S-485	✓		400 mm
RHT Climate-DM-400S-485-LCD	✓	✓	400 mm

Table 1

4 DISPLAY INDICATIONS

4.1 HOME SCREEN

The home screen displays 3 lines:

- 1) Line 1 displays the temperature read by the sensor.
- 2) Line 2 displays the value of relative humidity.
- 3) Line 3 displays the value of the option selected when configuring the device.

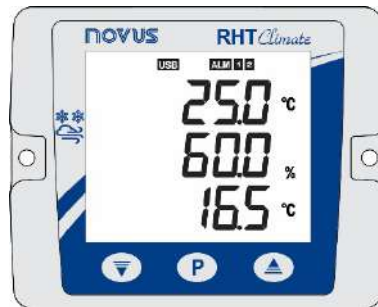





Figure 4

4.2 DISPLAYING MAXIMUM AND MINIMUM VALUES

To navigate to the secondary screens, you need to press the key **P** with a short touch from the home screen. With each short touch of the key, the display will show the following screens:

TEMPERATURE (t)	RELATIVE HUMIDITY (rH)	DEW POINT (t_d)
		
Figure 5	Figure 6	Figure 7

On the central line, the display will show the name of the variable to which the maximum and minimum values refer:

- t : Temperature
- rH : Relative humidity
- t_d : Dew point

On the upper line of the display is the **MAX** symbol, followed by the maximum value for that magnitude. On the lower line of the display is the **MIN** symbol, followed by the minimum value. If no key is pressed for 15 seconds, the display will return to the home screen.

4.3 DISPLAYING OTHER PSYCHROMETRIC PROPERTIES

After the screens of maximum and minimum values, are available screens for viewing other psychrometric variables. The device will advance one screen each short touch of the key **P**, respecting the following sequence:

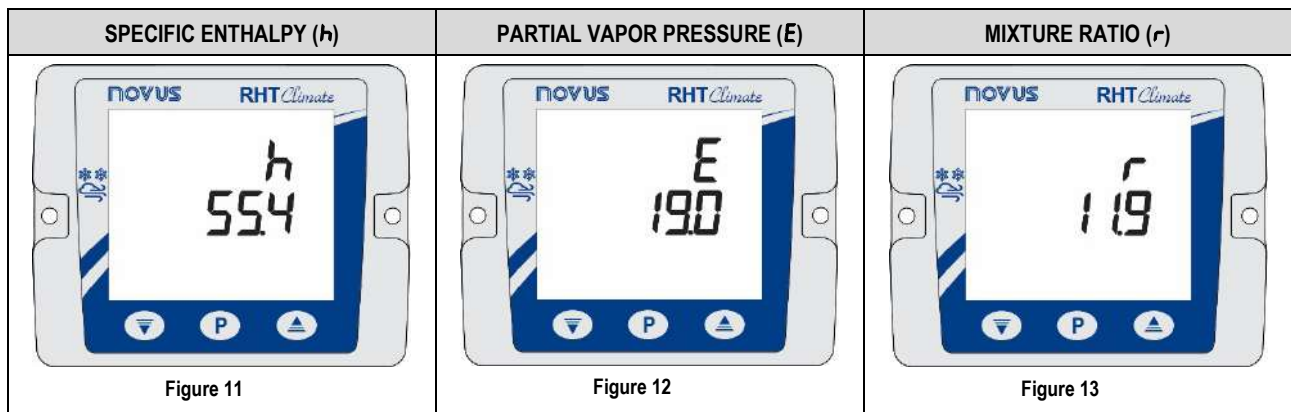
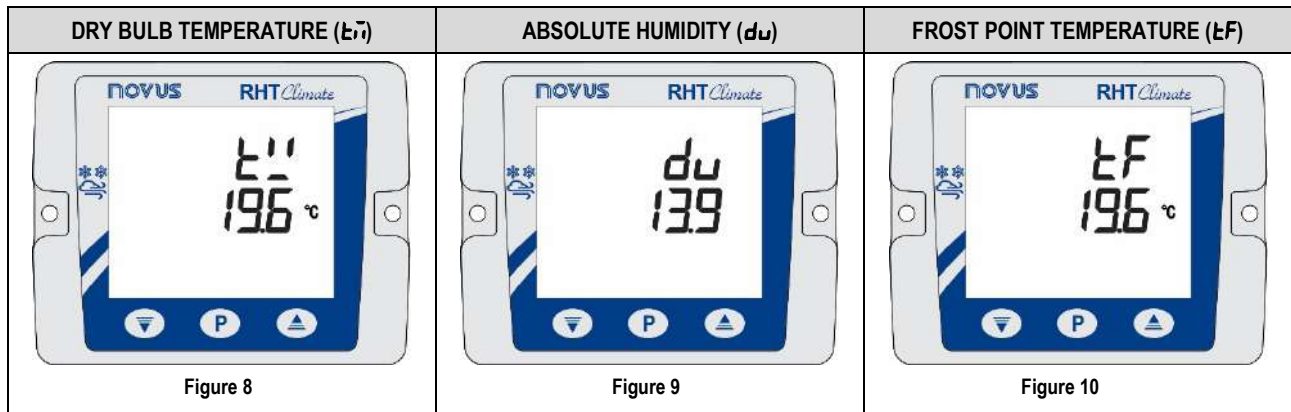

For more information on psychrometry properties, see [APPENDIX 1 – NOTIONS ABOUT PSYCHROMETRY](#).

4.4 SIGNALS

- **ALM + 1**: Indicates that the alarm 1 output is in alarm condition.
- **ALM + 1 flashing**: Indicates that the alarm 1 output is in alarm condition, but the output is disabled due to overcurrent protection.
- **ALM + 2**: Indicates that the alarm 2 output is in alarm condition.
- **ALM + 2 flashing**: Indicates that the alarm 2 output is in alarm condition, but the output is disabled due to overcurrent protection.
- **BUZZER**: The buzzer may be activated in 3 conditions:
 - BUZZER output alarm.
 - ALM1 output alarm if the buzzer is enabled in alarm 1 configuration.
 - ALM2 output alarm if the buzzer is enabled in alarm 2 configuration.
- **USB**: Indicates that the device is connected to a USB port.
- **COM flashing**: Indicates that the device is responding to a data request or command.
- **nnnn**: Indicates that the value to be displayed on one of the lines is above the display limit.
- **uuuu**: Indicates that the value to be shown on one of the lines is below the display limit.

5 INSTALLATION

5.1 MECHANICAL INSTALLATION

5.1.1 RHT *Climate* WM²

The RHT *Climate* Transmitter WM model was designed to be secured to a wall by two mounting holes on the transmitter, as shown in **Figure 14**.

Mounting should follow the sequence of steps below:

- Use the device perforation template to mark the position of transmitter mounting bore holes.
- Make the two holes using a drill with bit number 6. The bore holes should be deeper than the size of bushings.
- Insert bushings in holes. Bushings should be completely inserted into the wall.
- Position the transmitter on the wall, aiming to align with the perforations, and use bolts to secure it to the wall.



Bolts and bushings do not come with the device.

The device should be mounted with the sensor capsule facing downward to ensure the specified precision and protection rating.

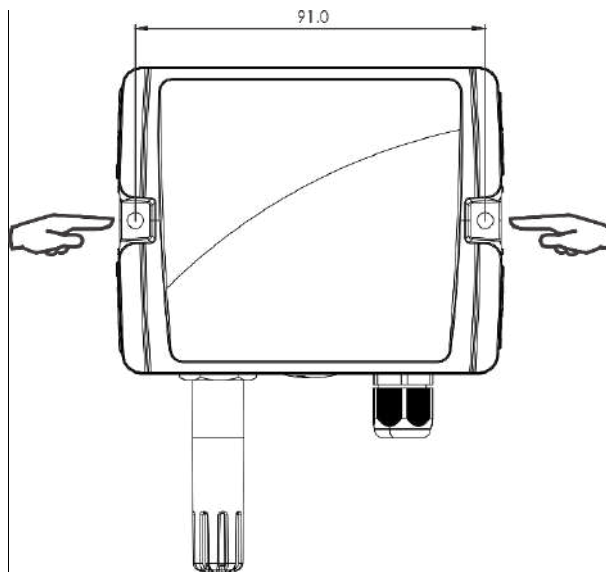

Figure 14

5.1.2 RHT *Climate* DM

The RHT *Climate* Transmitter DM model is mounted via a flange. First the flange is mounted on the duct wall, then the transmitter rod is inserted into the central bore hole on the flange and secured.

² Dimensions in millimeters.

5.1.3 DIMENSIONS³

5.1.3.1 RHT *Climate* TRANSMITTER – WM MODEL

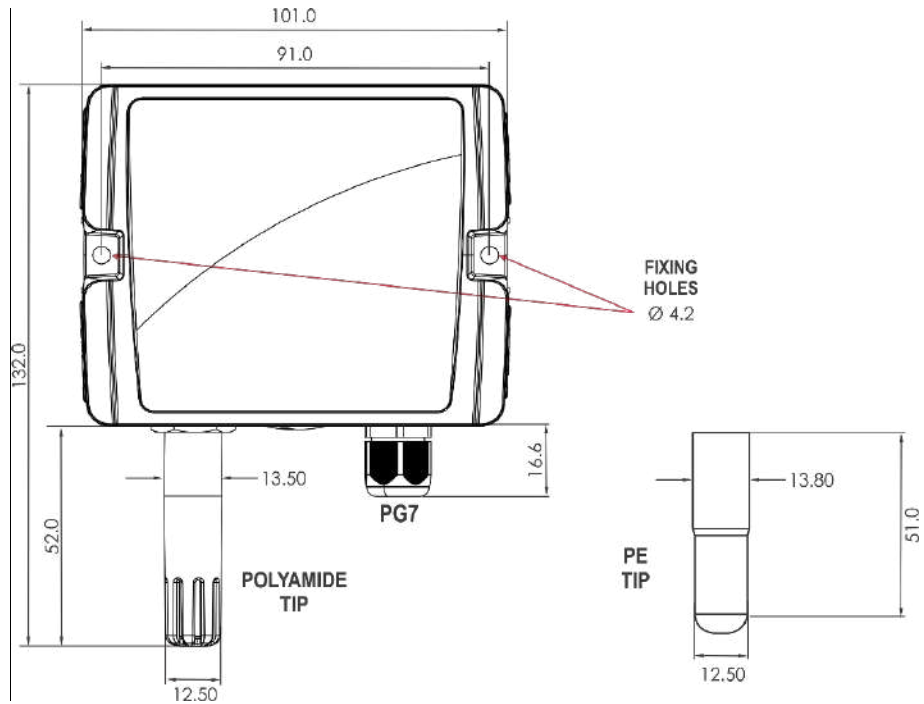

Figure 15

5.1.3.2 RHT *Climate* TRANSMITTER – DM MODEL

The figure below shows the flange dimensions and perforation:

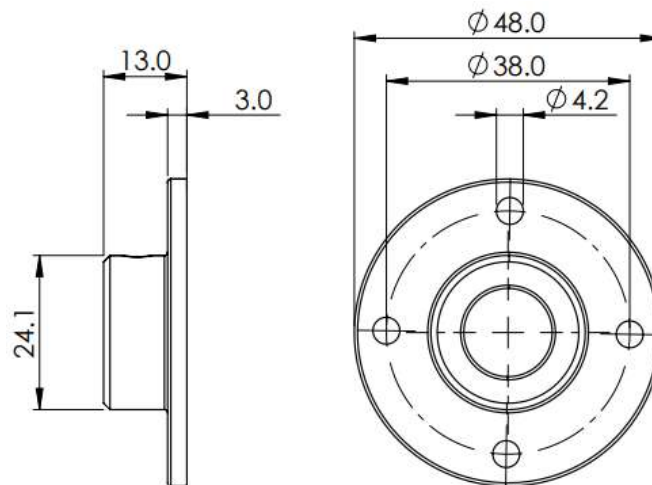

Figure 16

³ Dimensions in millimeters.

The probes for these models are made of stainless steel, with lengths of 150, 250, or 400 mm⁴:

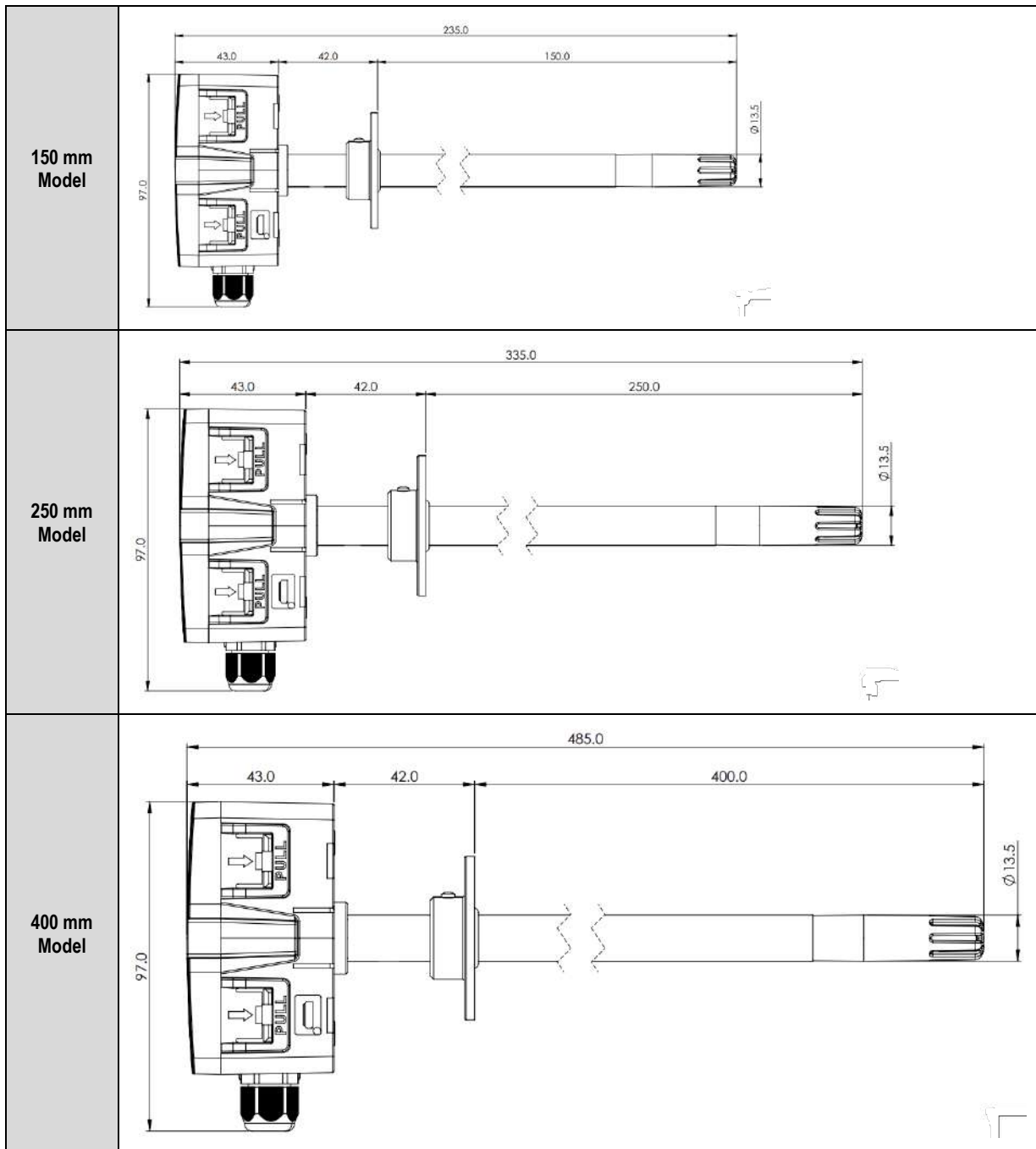

Figure 17

⁴ The figures show the dimensions of the RHT *Climate* Transmitter with the Polyamide tip.

5.1.4 REMOVING AND INSTALLING THE FRONT COVER

To remove the front cover, insert a screwdriver. It is necessary to fit in the lateral handles and to force it lightly until realizing its release. The procedure should be repeated on each of the side handles of the device, as shown in the figures below. With all sides clear, the cover can be easily removed:

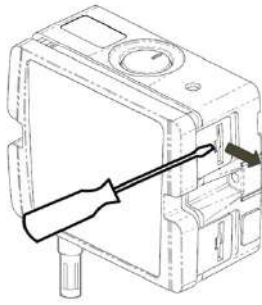

Figure 18

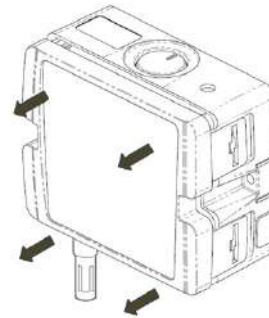

Figure 19

To install, fit the cover onto the base by pressing it with care to fully secure the transmitter, as shown in the figure below:

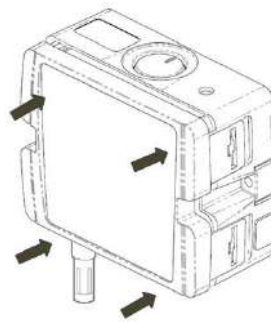

Figure 20

5.2 TYPES OF TIPS

NOVUS offers 2 types of tips, which can be purchased from authorized distributors:

- **Polyamide tip** (see figure beside): It has side openings that allow the sensor to be more exposed to the environment in which it was installed, having a shorter response time. This tip comes with **RHT Climate Transmitter**.

Order code: 8803900150



- **High Density Polyethylene (PE) tip** (see figure beside): Made of a porous material, it protects the sensor from dust and other solid particles. However, by reducing contact with the environment to be measured, the response time of this tip tends to be longer than that of the Polyamide tip (see **Note 1**).

Order code: 8803900130



Note 1: This increase in response time depends, among other things, on the speed of the air (or gas) where the sensor is inserted.

5.2.1 INSTALLATION

1. Remove the tip from RHT by slowly unscrewing it. When removing it, take care that only the tip rotates in the equipment.
2. The sensor circuit board will be exposed. It must not be touched!
3. Screw in the new tip carefully. It is not necessary to force the thread at the end.

5.3 ELECTRICAL INSTALLATION

5.3.1 INSTALLATION RECOMMENDATIONS

- Signal conductors should run through the plant separately from the power supply and output conductors. If possible, in grounded conduits.
- The power supply for electronic instruments must come from an appropriate grid for instruments.
- RC FILTERS (noise suppressor) are recommended in contactor coils, solenoids, etc.
- In control applications, it is essential to consider what could happen when some part of the system fails. The device's internal devices do not ensure total protection.
- Grounding helps limit the effects of noise due to electromagnetic interference (EMI). Run the grounding connection by using the grounding bolt and the grounding plane before turning on the device.

5.3.2 SPECIAL PRECAUTION

Because the transmitter is an electronic module, it requires some care when handling:

- When opening the transmitter to connect electrical wiring, avoid contact with the electronic circuit due to the risk of damage caused by static electricity.
- Pay close attention when connecting wires.
- Remember to pass all wires through a cable clip before completing electrical connections.
- When closing the housing, the cover should be placed again properly, ensuring proper sealing for this model.



5.3.3 ELECTRICAL CONNECTIONS

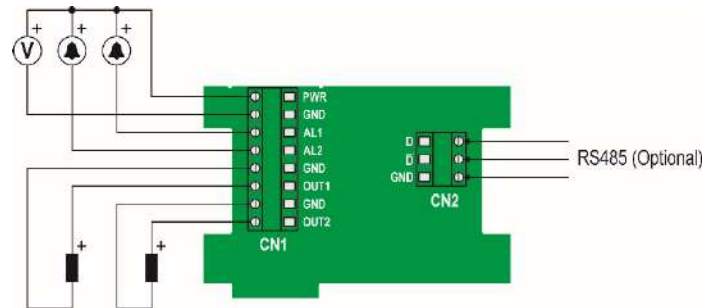

Figure 21

* Connector CN2 is only mounted on models that have RS485 interface (Optional).

5.3.4 USB CONNECTION

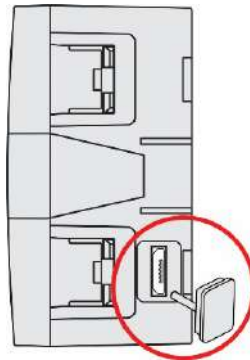



Figure 22

5.4 SENSOR MAINTENANCE

5.4.1 PRECAUTIONS WITH SENSORS

	<p>The sensor used in the RHT <i>Climate</i> Transmitter is a device that is sensitive to electrostatic discharge (ESD). Whenever the sensor is touched, measures need to be taken to prevent ESD damage.</p> <p>The sensor may be damaged or lose its calibration if exposed to atmospheres contaminated with chemical agents. Hydrochloric Acid, Nitric Acid, Sulfuric Acid and Ammonia at high concentrations can damage the sensor. Acetone, Ethanol and Propylene Glycol can cause reversible measurement errors.</p>
---	--

The humidity sensor calibration can be altered if it is exposed to contaminating vapors or extreme humidity and temperature conditions for prolonged periods. To speed up calibration restore, proceed as described below:

- Carefully remove the sensor from the capsule, avoiding contact with bare hands (it must be removed with the use of plastic tweezers or clean antistatic gloves).
- If there are solid particles on the sensor, wash it with deionized water at room temperature.
- Place the sensor in an oven at 120 °C (+/-10 °C) for 6 hours.
- Carefully replace the sensor in the capsule.

It is also possible to clean or dry the sensor using filtered and oil-free air, taking care that the air jets do not mechanically damage the sensor.

5.4.2 SENSOR REPLACEMENT

In case of damage, the humidity and temperature sensor may need to be replaced. To perform this procedure, follow the steps below:



- **Step 1:** Disconnect the transmitter from the power supply and remove the USB cable if it is connected. Locate the sensor protective tip.

This example shows the sensor replacement of an RHT *Climate* DM Transmitter. In it, the sensor is located at the end of the rod.



- **Step 2:** Remove the tip by turning it counterclockwise.



- **Step 3:** Without the tip the sensor will be exposed. Remove it by pulling it forward to disconnect it.

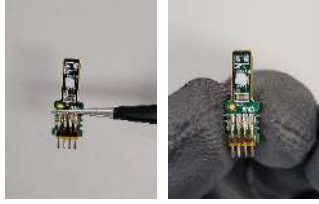

- **Step 4:** Connect the new sensor to the rod tip connector with the aid of plastic tweezers or clean antistatic gloves, avoiding pushing or engaging the sensor by hand only.

	 <p>Hold the sensor only by its terminals, using plastic tweezers or new gloves.</p>
---	--

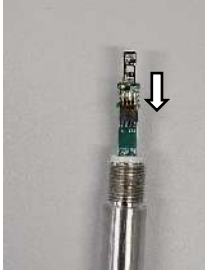

<p>Do not hold the sensor by the sensor element. Do not use metal tweezers. Do not touch the sensor without wearing gloves.</p>		

- **Step 5:** Place the protection tip again and turn it clockwise to secure it to the device.



Once the sensor is replaced, it will be automatically recognized by the equipment.

6 PARAMETER CYCLES

The configuration parameters are clustered in affinity groups, called parameter cycles. The 10 parameter cycles are:

CYCLE	ACCESS
1 - Primary Cycle: In this cycle are the screens for viewing the psychrometric variables.	Unrestricted access
2 - Out 1 Cycle: In this cycle are the configuration parameters of the transmission 1 output.	Enables the protection mode of these cycles
3 - Out 2 Cycle: In this cycle are the configuration parameters of the transmission 2 output.	
4 - AL1 Cycle: In this cycle are the configuration parameters of the alarm 1 output.	
5 - AL2 Cycle: In this cycle are the configuration parameters of the alarm 2 output.	
6 - buz Cycle: In this cycle are the configuration parameters of the buzzer.	
7 - HMI Cycle: In this cycle are the HMI configuration parameters.	
8 - dRG Cycle: In this cycle are the parameters for forcing values of temperature, relative humidity and transmission outputs, alarm, and buzzer.	
9 - COM Cycle: In this cycle, you can configure parameters related to RS485 Modbus communication.	
10 - CFG Cycle: You must enter the device password to access the parameters in this cycle. The parameters allow the selection of the measurement units, the adjustment of the atmospheric pressure, besides the offsets and the digital filters for the sensor readings. You also can enable the protection of the configuration parameters and change the password.	
11 - Information Cycle: In this cycle are displayed the serial number (Sn) and the firmware version (Fv) of the device.	

Table 2

7 CONFIGURATION

RHT *Climate* Transmitter has a set of parameters that allows the configuration of its two transmission outputs and its two alarm outputs and can assigning the psychrometric properties below to each of them. The properties can be expressed in the International System of Measures (SI) or in the English System of Measures (US).

Psychrometric properties		SI			US		
		Min.	Max.	Unit	Min.	Max.	Unit
Temperature (measured value)	t	-40	100	°C	-40	212	°F
Relative humidity (measured value)	rH	0	100	% RH	0	100	% RH
Dew point temperature (calculated value)	td	-90	100	°C	-130	212	°F
Wet bulb temperature (calculated value)	t'w	-40	100	°C	-40	212	°F
Absolute humidity (calculated value)	du	0	600	g/m ³	0	262	gr/ft ³
Frost point temperature (calculated value)	tF	-90	100	°C	-130	212	°F
Specific enthalpy (calculated value)	h	-40	700000*	kJ/kg	-18	300945*	BTU/lb
Partial vapor pressure (calculated value)	E	0	1035	mbar	0	15	psi
Mixture ratio (calculated value)	r	0	260000*	g/kg	0	1820000*	gr/lb

Temperature and relative humidity are the only variables that are measured directly from the sensor that comes with the device. All other measurements are obtained via algorithms that can lead to slight variations in relation to the real values.

Table 3

7.1 ANALOG OUTPUTS **Out 1 / Out 2**

The configuration cycle for analog outputs 1 and 2 allows you to assign:

- The psychrometric property related to the output.
- The default electrical output.
- The value to be shown in case of error in the sensor reading.
- The excursion range of the transmitted psychrometric property.

Note: When the lower limit is defined with a value higher than the higher limit, the output current operates from 20-4 mA to 10-0 V.

7.1.1 Psychrometric property to be transmitted by the analog outputs **Out 1 / Out 2**

It allows you to configure the psychrometric property to be transmitted by the analog outputs **Out 1 / Out 2**.

	Psychrometric property to be transmitted	Default: oFF	Modbus register value
Out 1 :ERS	Outputs Out 1 / Out 2 off	oFF	0
	Temperature	t	1
	Relative humidity	rH	2
	Dew point temperature	td	3
Out 2 :ERS	Wet bulb temperature	t'w	4
	Absolute humidity	du	5
	Frost point temperature	tF	6
	Specific enthalpy	h	7
	Partial vapor pressure	E	8
	Mixture ratio	r	9

Table 4

7.1.2 Analog outputs **Out 1 / Out 2** operating mode

It allows you to configure the type of electric signal to be used by the analog outputs **Out 1 / Out 2**.

	Signal type of the analog outputs Out 1 / Out 2	Default: 4-20	Modbus register value
Out 1 :ode	Analog output 1 operating in 4-20 mA mode	4-20	0
Out 2 :ode	Analog output 1 operating in 0-10 V mode	0-10	1

Table 5

7.1.3 Lower transmission range limit of analog outputs *Out 1 / Out 2*

It allows you to configure the lower full-scale for analog outputs *Out 1 / Out 2*.

	Lower transmission range limit of analog outputs <i>Out 1 / Out 2</i>	SI				US			
		Min.	Max.	Unit	Default	Min.	Max.	Unit	Default
<i>Out 1</i> L-Lo	Temperature <i>t</i>	-40	100	°C	-40	-40	212	°F	-40
	Relative humidity <i>rH</i>	0	100	% RH	0	0	100	% RH	0
	Dew point temperature <i>t_d</i>	-90	100	°C	-90	-130	212	°F	-130
	Wet bulb temperature <i>t_w</i>	-40	100	°C	-40	-40	212	°F	-40
<i>Out 2</i> L-Lo	Absolute humidity <i>dU</i>	0	600	g/m ³	0	0	262	gr/ft ³	0
	Frost point temperature <i>t_F</i>	-90	100	°C	-90	-130	212	°F	-130
	Specific enthalpy <i>h</i>	-40	700000*	kJ/kg	-40	-18	300945*	BTU/lb	-18
	Partial vapor pressure <i>E</i>	0	1035	mbar	0	0	15	psi	0
	Mixture ratio <i>r</i>	0	260000*	g/kg	0	0	1820000*	gr/lb	0

Table 6

* These values exceed the maximum value shown in the display. Through the HMI, you can adjust up to the 19999 limit. When configured by SigNow, these parameters can be adjusted up to the values shown in the table above. When accessing these parameters from the HMI, however, the **nnnn** value will be displayed.

7.1.4 Upper transmission range limit of analog outputs *Out 1 / Out 2*

It allows you to configure the upper full-scale for analog outputs *Out 1 / Out 2*.

	Lower transmission range limit of analog outputs <i>Out 1 / Out 2</i>	SI				US			
		Min.	Max.	Unit	Default	Min.	Max.	Unit	Default
<i>Out 1</i> L-Hi	Temperature	-40	100	°C	100	-40	212	°F	212
	Relative humidity	0	100	% RH	100	0	100	% RH	100
	Dew point temperature	-90	100	°C	100	-130	212	°F	212
	Wet bulb temperature	-40	100	°C	100	-40	212	°F	212
<i>Out 2</i> L-Hi	Absolute humidity	0	600	g/m ³	600	0	262	gr/ft ³	262
	Frost point temperature	-90	100	°C	100	-130	212	°F	212
	Specific enthalpy	-40	700000*	kJ/kg	700000*	-18	300945*	BTU/lb	300945*
	Partial vapor pressure	0	1035	mbar	1035	0	15	psi	15
	Mixture ratio	0	260000*	g/kg	260000*	0	1820000*	gr/lb	1820000*

Table 7

* These values exceed the maximum value shown in the display. Through the HMI, you can adjust up to the 19999 limit. When configured by SigNow, these parameters can be adjusted up to the values shown in the table above. When accessing these parameters from the HMI, however, the **nnnn** value will be displayed.

7.1.5 Status of analog outputs *Out 1 / Out 2* in case of sensor error

It allows you to configure the status of analog outputs *Out 1 / Out 2* in case of error in the sensor reading.

<i>Out 1</i> Err	Value of analog outputs <i>Out 1 / Out 2</i> in case of error	Default: Lo	Modbus register value
<i>Out 2</i> Err	Sets analog outputs <i>Out 1 / Out 2</i> to the minimum value in case of error in the sensor reading.	Lo	0
	Sets the analog outputs <i>Out 1 / Out 2</i> to the maximum value in case of error in the sensor reading.	Hi	1

Table 8

7.2 ALARM OUTPUTS AL_{11} / AL_{12}

All RHT *Climate* Transmitter models have 2 alarm outputs, which can also be used with ON/OFF control outputs. For models with display, there is the additional feature of an internal buzzer for audible signaling. For each alarm output and for the buzzer, the following can be configured:

- The associated psychrometric property
- Alarm type L_o , H_i , $L--H$, $-LH-$
- The setpoints
- Hysteresis
- Output condition in case of sensor error
- Timing

The configuration cycle for alarms AL_{11} / AL_{12} allows for assigning the psychrometric property associated with alarm outputs AL_{11} / AL_{12} , the operating mode for alarms AL_{11} / AL_{12} (type of alarm), activation points for alarms AL_{11} / AL_{12} , their timing values, inhibition of alarm condition when turning the device on, and the alarm activation mode in case of sensor reading error.

The figure below shows how the alarm outputs are activated and deactivated according to the type of alarm selected.

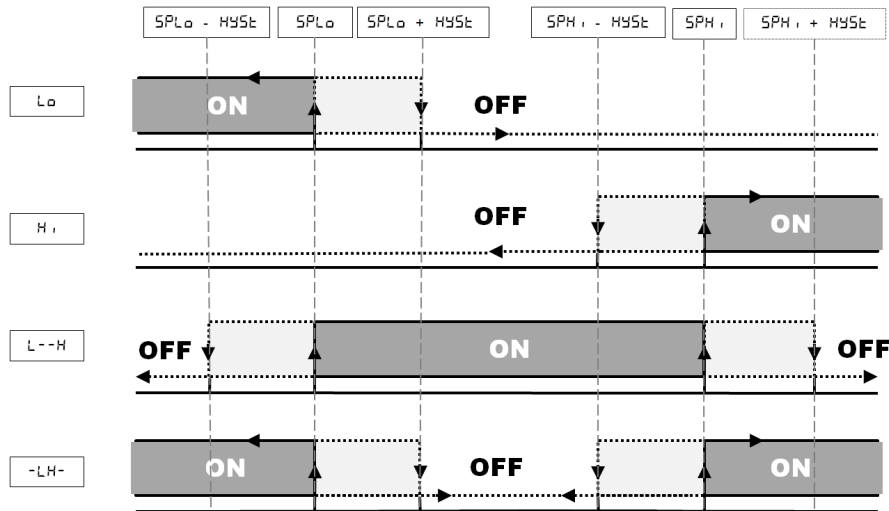

Figure 23

RHT *Climate* Transmitter allows for 4 timing options for its alarm outputs and for the buzzer:

- Normal operation
- Activation for set time
- Delay in activation
- Intermittent activation

The figures in the table below show the behavior of alarm outputs with these activation variations defined by the t_{ON} and t_{OFF} time intervals:

OPERATION	t_{ON}	t_{OFF}	ACTION
Normal operation	0	0	Alarm Output is ON immediately after Alarm Event.
Activation with set time	1 to 6500 s	0	Alarm Output is ON after a delay of t_{ON} after Alarm Event.
Delayed activation	0	1 to 6500 s	Alarm Output is ON immediately after Alarm Event, but remains ON for a delay of t_{OFF} after the event.
Intermittent activation	1 to 6500 s	1 to 6500 s	Alarm Output is ON after a delay of t_{ON} , remains ON for a delay of t_{OFF} , and then turns OFF after a delay of t_{ON} .

Table 9

The **Initial Blocking** option prevents alarm activation if there is an alarm condition when the controller is turned on. The alarm is only enabled after the process passes through a non-alarm condition.

The initial block is useful, for example, when one of the alarms is configured as minimum value alarm, potentially setting off the alarm right when the process is started up, which is often undesirable behavior.

Initial blocking is not valid for the **Open Sensor** function.

7.2.1 Psychrometric property associated with alarms AL_{n1} / AL_{n2}

It allows you to configure a psychrometric property that will be associated with alarms AL_{n1} / AL_{n2} .

	Psychrometric property associated with alarms AL_{n1} / AL_{n2}	Default: t	Modbus Register Value
AL_{n1} $ERR5$	Temperature	t	1
	Relative humidity	rH	2
	Dew point temperature	t_d	3
	Wet bulb temperature	t_w	4
AL_{n2} $ERR5$	Absolute humidity	dU	5
	Frost point temperature	t_F	6
	Specific enthalpy	h	7
	Partial vapor pressure	E	8
	Mixture ratio	r	9

Table 10

7.2.2 Activation mode for alarms AL_{n1} / AL_{n2}

It allows you to turn off alarms AL_{n1} / AL_{n2} or configure them to operate as one of the alarm types indicated below:

	Activation mode for alarm outputs AL_{n1} / AL_{n2}	Default: OFF	Modbus Register Value
AL_{n1} $mode$	Off	OFF	0
	Sets off alarm in case of sensor error	Err	1
AL_{n2} $mode$	Sets off alarm below setpoint $SPLo$	Lo	2
	Sets off alarm above setpoint $SPHi$	Hi	3
	Sets off alarm between $SPLo$ and $SPHi$	$L-H$	4
	Sets off alarm below $SPLo$ and above $SPHi$	$-LH-$	5

Table 11

7.2.3 Lower Setpoint for activating alarms AL_{n1} / AL_{n2}

It allows you to configure the setpoint for alarms Lo , $L-H$, and $-LH-$.

	Setpoint lower than alarm outputs AL_{n1} / AL_{n2}	SI				US			
		Min.	Max.	Unit	Default	Min.	Max.	Unit	Default
AL_{n1} $SPLo$	AL_{n1} / AL_{n2} for temperature	-40	100	°C	-40	-40	212	°F	-40
	AL_{n1} / AL_{n2} for relative humidity	0	100	% RH	0	0	100	% RH	0
	AL_{n1} / AL_{n2} for dew point temperature	-90	100	°C	-90	-130	212	°F	-130
	AL_{n1} / AL_{n2} for wet bulb temperature	-40	100	°C	-40	-40	212	°F	-40
AL_{n2} $SPLo$	AL_{n1} / AL_{n2} for absolute humidity	0	600	g/m ³	0	0	262	gr/ft ³	0
	AL_{n1} / AL_{n2} for frost point temperature	-90	100	°C	-90	-130	212	°F	-130
	AL_{n1} / AL_{n2} for specific enthalpy	-40	700000*	kJ/kg	-40	-18	300945*	BTU/lb	-18
	AL_{n1} / AL_{n2} for partial vapor pressure	0	1035	Mbar	0	0	15	psi	0
	AL_{n1} / AL_{n2} for mixture ratio	0	260000*	g/kg	0	0	1820000*	gr/lb	0

Table 12

* These values exceed the maximum value shown in the display. Through the HMI, you can adjust up to the 19999 limit. When configured by SigNow, these parameters can be adjusted up to the values shown in the table above. When accessing these parameters from the HMI, however, the **0000** value will be displayed.

7.2.4 Higher Setpoint for activating alarms AL_{n1} / AL_{n2}

It allows you to configure the setpoint for alarm types H , L , $-H$, and $-L$.

		SI				US			
Setpoint higher than alarm outputs AL_{n1} / AL_{n2}		Min.	Max.	Unit	Default	Min.	Max.	Unit	Default
AL_{n1} SPH	AL_{n1} / AL_{n2} for temperature	-40	100	°C	100	-40	212	°F	212
	AL_{n1} / AL_{n2} for relative humidity	0	100	% RH	100	0	100	% RH	100
	AL_{n1} / AL_{n2} for dew point temperature	-90	100	°C	100	-130	212	°F	212
	AL_{n1} / AL_{n2} for wet bulb temperature	-40	100	°C	100	-40	212	°F	212
AL_{n2} SPH	AL_{n1} / AL_{n2} for absolute humidity	0	600	g/m ³	600	0	262	gr/ft ³	262
	AL_{n1} / AL_{n2} for frost point temperature	-90	100	°C	100	-130	212	°F	212
	AL_{n1} / AL_{n2} for specific enthalpy	-40	700000*	kJ/kg	700000*	-18	300945*	BTU/lb	300945*
	AL_{n1} / AL_{n2} for partial vapor pressure	0	1035	mbar	1035	0	15	psi	15
	AL_{n1} / AL_{n2} for mixture ratio	0	260000*	g/kg	260000*	0	1820000*	gr/lb	1820000*

Table 13

* These values exceed the maximum value shown in the display. Through the HMI, you can adjust up to the 19999 limit. When configured by SigNow, these parameters can be adjusted up to the values shown in the table above. When accessing these parameters from the HMI, however, the 9999 value will be displayed.

7.2.5 Hysteresis for turning off alarms AL_{n1} / AL_{n2}

It allows you to adjust the differential for turning off alarms AL_{n1} / AL_{n2} .

		SI				US			
Output hysteresis of alarms AL_{n1} / AL_{n2}		Min.	Max.	Unit	Default	Min.	Max.	Unit	Default
AL_{n1} HYS	AL_{n1} / AL_{n2} for temperature	0	20	°C	0	0	20	°F	0
	AL_{n1} / AL_{n2} for relative humidity	0	20	% RH	0	0	20	% RH	0
	AL_{n1} / AL_{n2} for dew point temperature	0	20	°C	0	0	20	°F	0
	AL_{n1} / AL_{n2} for wet bulb temperature	0	20	°C	0	0	20	°F	0
AL_{n2} HYS	AL_{n1} / AL_{n2} for absolute humidity	0	20	g/m ³	0	0	20	gr/ft ³	0
	AL_{n1} / AL_{n2} for frost point temperature	0	20	°C	0	0	20	°F	0
	AL_{n1} / AL_{n2} for specific enthalpy	0	20	kJ/kg	0	0	20	BTU/lb	0
	AL_{n1} / AL_{n2} for partial vapor pressure	0	20	mbar	0	0	20	psi	0
	AL_{n1} / AL_{n2} for mixture ratio	0	20	g/kg	0	0	20	gr/lb	0

Table 14

7.2.6 Alarms AL_{n1} / AL_{n2} on time

		Min.	Max.	Unit	Default
AL_{n1} t_{ON}	Time of alarms on.	0	6500	s	0
AL_{n2} t_{ON}					

Table 15

7.2.7 Alarms AL_{n1} / AL_{n2} off time

		Min.	Max.	Unit	Default
AL_{n1} t_{OFF}	Time of alarms off.	0	6500	s	0
AL_{n2} t_{OFF}					

Table 16

7.2.8 Initial blocking of alarms AL_{11} / AL_{12}

It allows blocking the activation of alarms AL_{11} / AL_{12} if the transmitter starts up in alarm condition.

AL_{11} bLR	Initial blocking of alarms AL_{11} / AL_{12}	Default: YES	Modbus Register Value
AL_{12} bLR	Without initial blocking of alarms AL_{11} / AL_{12} .	no	0
	With initial blocking of alarms AL_{11} / AL_{12} .	YES	1

Table 17

7.2.9 Status of alarms AL_{11} / AL_{12} in case of sensor error

It allows you to configure the outputs from alarms AL_{11} / AL_{12} so that they are activated in case of sensor reading error.

AL_{11} Err	Status of alarm outputs AL_{11} / AL_{12} in case of sensor error	Default: oFF	Modbus Register Value
AL_{12} Err	Alarms AL_{11} / AL_{12} off	oFF	0
	Alarms AL_{11} / AL_{12} on	on	1

Table 18

7.2.10 Enable buzzer activation linked to alarms AL_{11} / AL_{12}

It allows you to enable buzzer activation linked to alarms AL_{11} / AL_{12} .

AL_{11} $bu22$	Enable buzzer for alarm outputs AL_{11} / AL_{12}	Default: d5bL	Modbus Register Value
AL_{12} $bu22$	The buzzer will not be activated when alarms AL_{11} / AL_{12} occur.	d5bL	0
	The buzzer will be activated when alarms AL_{11} / AL_{12} occur.	EnbL	1

Table 19

7.3 BUZZER CONFIGURATION CYCLE

The buzzer configuration cycle allows for assigning the psychrometric property associated with the buzzer, the buzzer operating mode (type of alarm), buzzer activation points, their timing values, inhibition of alarm condition when turning the device on, and the buzzer activation mode in case of sensor reading error.

7.3.1 Psychrometric property associated with the buzzer

It allows you to configure the psychrometric property that will be associated with the buzzer.

$bu22$ $NEAS$	Psychrometric property associated with the buzzer	Default: t	Modbus Register Value
	Temperature	t	1
	Relative humidity	rH	2
	Dew point temperature	tD	3
	Wet bulb temperature	tW	4
	Absolute humidity	dU	5
	Frost point temperature	tF	6
	Specific enthalpy	h	7
	Partial vapor pressure	E	8
	Mixture ratio	r	9

Table 20

7.3.2 Buzzer activation mode

It allows you to turn off the buzzer or configure it to operate as one of the alarm types set forth below:

$bu22$ $modE$	Buzzer activation mode	Default: oFF
	Off	oFF
	Activates the alarm in case of sensor error	Err
	Activates alarm below setpoint SPLo	Lo
	Activates alarm above setpoint SPHi	Hi
	Activates alarm between SPLo and SPHi	L-H
Activates alarm below SPLo and above SPHi	-LH-	

Table 21

7.3.3 Lower psychrometric property setpoint for buzzer activation

It allows you to configure the setpoint for alarms **Lo**, **L--H**, and **-LH-**.

		SI				US			
bu22 SPLo	Psychrometric property	Min.	Max.	Unit	Default	Min.	Max.	Unit	Default
	Temperature	-40	100	°C	-40	-40	212	°F	-40
	Relative humidity	0	100	% RH	0	0	100	% RH	0
	Dew point temperature	-90	100	°C	-90	-130	212	°F	-130
	Wet bulb temperature	-40	100	°C	-40	-40	212	°F	-40
	Absolute humidity	0	600	g/m ³	0	0	262	gr/ft ³	0
	Frost point temperature	-90	100	°C	-90	-130	212	°F	-130
	Specific enthalpy	-40	700000*	kJ/kg	-40	-18	300945*	BTU/lb	-18
	Partial vapor pressure	0	1035	mbar	0	0	15	psi	0
	Mixture ratio	0	260000*	g/kg	0	0	1820000*	gr/lb	0

Table 22

* These values exceed the maximum value shown in the display. Through the HMI, you can adjust up to the 19999 limit. When configured by SigNow, these parameters can be adjusted up to the values shown in the table above. When accessing these parameters from the HMI, however, the **9999** value will be displayed.

7.3.4 Higher Setpoint for buzzer activation

It allows you to configure the set point for alarm types **H+**, **L--H**, and **-LH-**.

		SI				US			
bu22 SPH+	Higher Setpoint for buzzer activation	Min.	Max.	Unit	Default	Min.	Max.	Unit	Default
	Temperature	-40	100	°C	100	-40	212	°F	212
	Relative humidity	0	100	% RH	100	0	100	% RH	100
	Dew point temperature	-90	100	°C	100	-130	212	°F	212
	Wet bulb temperature	-40	100	°C	100	-40	212	°F	212
	Absolute humidity	0	600	g/m ³	600	0	262	gr/ft ³	262
	Frost point temperature	-90	100	°C	100	-130	212	°F	212
	Specific enthalpy	-40	700000*	kJ/kg	700000*	-18	300945*	BTU/lb	300945*
	Partial vapor pressure	0	1035	mbar	1035	0	15	psi	15
	Mixture ratio	0	260000*	g/kg	260000*	0	1820000*	gr/lb	1820000*

Table 23

* These values exceed the maximum value shown in the display. Through the HMI, you can adjust up to the 19999 limit. When configured by SigNow, these parameters can be adjusted up to the values shown in the table above. When accessing these parameters from the HMI, however, the **9999** value will be displayed.

7.3.5 Hysteresis for turning off buzzer

It allows you to adjust the differential for turning off the buzzer.

		SI				US			
bu22 HYSt	Hysteresis for turning off buzzer	Min.	Max.	Unit	Default	Min.	Max.	Unit	Default
	Temperature	0	20	°C	0	0	20	°F	0
	Relative humidity	0	20	% RH	0	0	20	% RH	0
	Dew point temperature	0	20	°C	0	0	20	°F	0
	Wet bulb temperature	0	20	°C	0	0	20	°F	0
	Absolute humidity	0	20	g/m ³	0	0	20	gr/ft ³	0
	Frost point temperature	0	20	°C	0	0	20	°F	0
	Specific enthalpy	0	20	kJ/kg	0	0	20	BTU/lb	0
	Partial vapor pressure	0	20	mbar	0	0	20	psi	0
	Mixture ratio	0	20	g/kg	0	0	20	gr/lb	0

Table 24

7.3.6 Buzzer on time

		Min.	Max.	Unit	Default
bu22 tOn	Buzzer on time	0	6500	s	0

Table 25

7.3.7 Buzzer off time

		Min.	Max.	Unit	Default
bu22 tOFF	Buzzer off time	0	6500	s	0

Table 26

7.3.8 Initial buzzer blocking

It allows blocking buzzer activation if the transmitter starts up in alarm condition.

bu22 bLR	Initial buzzer blocking	Default: YES	Modbus Register Value
	Without initial buzzer blocking	no	0
	With initial buzzer blocking	YES	1

Table 27

7.3.9 Buzzer status in case of sensor error

It allows you to configure the buzzer output so that it is activated in case of sensor reading error.

bu22 Err	Buzzer status in case of sensor error	Default: oFF	Modbus Register Value
	Buzzer off	oFF	0
	Buzzer on	on	1

Table 28

7.4 HMI CONFIGURATION CYCLE

The HMI configuration cycle allows for adjusting contrast, display backlight operating mode and functions of increase and decrease keys.

7.4.1 Backlight

It adjusts the display backlight operating mode.

HMI bclt	Backlight	Default: on	Modbus Register Value
	Off	oFF	0
	Always on	on	1
	On for 15 seconds after pressing any key	Pr55	2

Table 29

7.4.2 Contrast

It adjusts the display contrast. Depending on the preferred viewing angle, the contrast may need to be adjusted to improve the clarity of information on the display.

HMI cont	Contrast	Default: 3
	Contrast 1 (-40° in relation to the horizontal line)	1
	Contrast 2 (-20° in relation to the horizontal line)	2
	Contrast 3 (0° in relation to the horizontal line)	3
	Contrast 4 (+20° in relation to the horizontal line)	4
	Contrast 5 (+40° in relation to the horizontal line)	5

Table 30

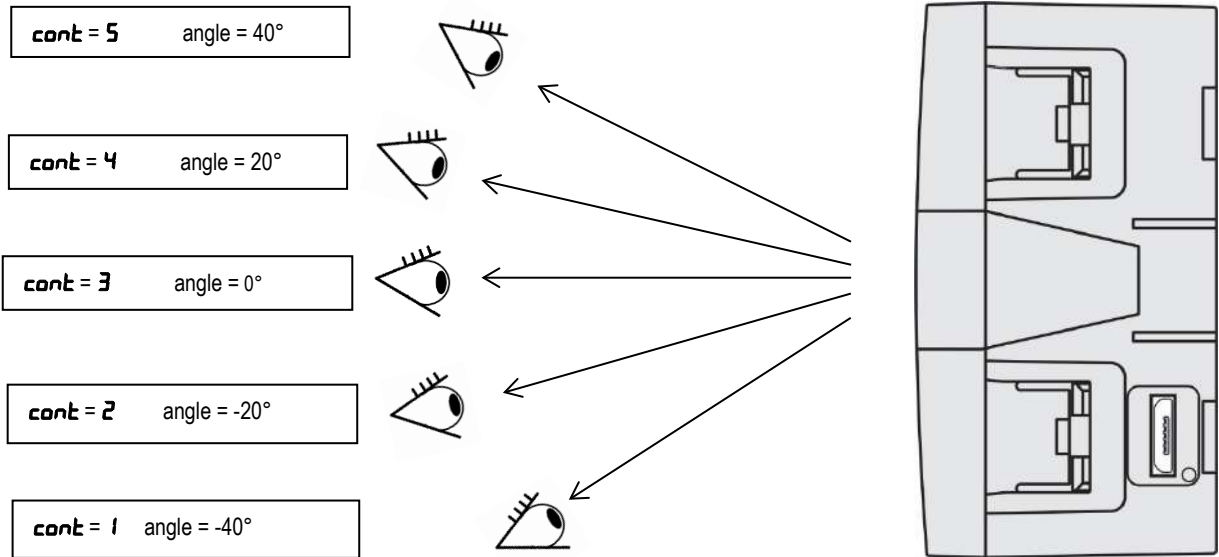

Figure 24

7.4.3 Second function of key

It allows you to configure the second function of the increase key.

IH1 F1	Second function of the increase key	Default: <i>nonE</i>	Modbus Register Value
	None	<i>nonE</i>	0
	Mutes buzzer	<i>b2</i>	1
	Mutes buzzer and turns off alarm output	<i>b2AL</i>	2

Table 31

7.4.4 Second function of key

It allows you to configure the second function of the decrease key.

IH1 F2	Second function of the decrease key	Default: <i>nonE</i>	Modbus Register Value
	None	<i>nonE</i>	0
	Clear maximum and minimum values	<i>CLr</i>	1

Table 32

7.4.5 Configuring the third line of the display

It allows you to configure the information to be displayed on the third line of the display.

IH1 Ln3	Third line of the display	Default: <i>td</i>	Modbus Register Value
	Dew point	<i>td</i>	0
	Wet bulb temperature	<i>tw</i>	1
	Absolute humidity	<i>du</i>	2
	Frost point	<i>tf</i>	3
	Specific enthalpy	<i>h</i>	4
	Partial vapor pressure	<i>E</i>	5
	Mixture ratio	<i>r</i>	6
	None	<i>oFF</i>	7

Table 33

7.5 DIAGNOSTIC CYCLE

The diagnostic cycle lets you evaluate the operation of RHT *Climate Transmitter*, making sure that all its peripherals are working properly.

7.5.1 Analog output $FoU1$ / $FoU2$ forcing

It allows you to force a current or voltage value at the analog output **OUT1** / **OUT2**. If the output is configured as output at voltage 0-10 V, you can adjust the value between 0.00 V and 10.00 V. If the output is configured as an output at current 4-20 mA, you can adjust the value between 4.00 mA and 20.00 mA (to check the operating range for the output in current). Above 20.0 mA, you will be able to adjust the output to 21.0 mA, to simulate the transmission failure signal. The same thing happens for the lower limit, which may shift to 3.6 mA.

The figure below shows the normal transmission range limits and the transmission failure signal zones.

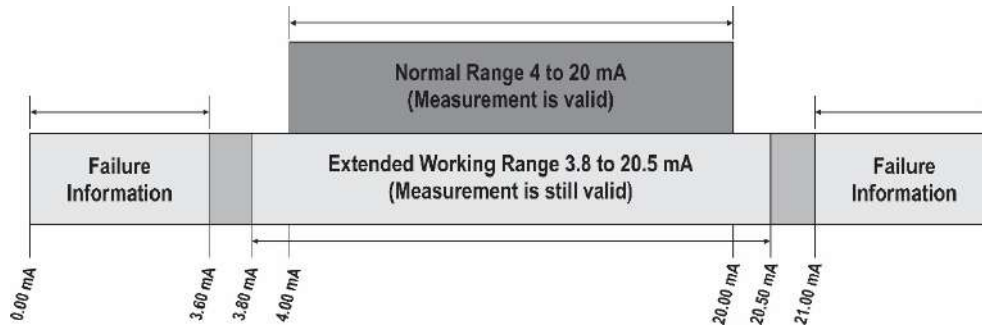

Figure 25

		Min.	Max.	Unit	Default
$d.AG$ $FoU1$	Forces voltage value at analog output 1. (If $Out1 / Out2$ mode = 0-10)	0	10.00	V	0
$d.AG$ $FoU2$	Forces current value at analog output 1. (If $Out1 / Out2$ mode = 4-20)	3.6	21.00	mA	4

Table 34

7.5.2 Temperature reading forcing

It allows you to force a temperature value. This feature can be used to simulate temperature alarms or alarms for other variables due to change.

		SI				US			
		Min.	Max.	Unit	Default	Min.	Max.	Unit	Default
$d.AG$ $F.t$	Forces the temperature reading value.	-40	100	°C	-40	-40	212	°F	-40

Table 35

7.5.3 Relative humidity reading forcing

It allows you to force a relative humidity value. This feature can be used to simulate relative humidity alarms or alarms for other variables due to change. If, for example, alarm output 1 is configured to activate whenever relative humidity is higher than 80% RH or lower than 40% RH, you can evidence the $AL1$ output operating as the forced value varies.

		Min.	Max.	Unit	Default
$d.AG$ $F.rH$	Forces relative humidity reading value.	0	100	%	0

Table 36

7.5.4 Alarm $AL1$ / $AL2$ output forcing

It allows you to force activation of alarm output $AL1$ / $AL2$.

$d.AG$ $FA1$ / $d.AG$ $FA1$	Forces alarm output $AL1$ / $AL2$	Default: off	Modbus Register Value
	Forces alarm $AL1$ / $AL2$ off output	off	0
	Forces alarm $AL1$ / $AL2$ on output	on	1

Table 37

7.5.5 Buzzer forcing

It allows you to force buzzer activation.

d .RG Fb22	Forces buzzer output	Default: <i>oFF</i>	Modbus Register Value
	Forces buzzer off output	<i>oFF</i>	0
	Forces buzzer on output	<i>on</i>	1

Table 38

7.6 COMMUNICATION CYCLE

In the communication cycle, you will find configuration parameters for the RS485 Modbus serial port: Baud rate, parity, and address.

Table 39 shows how to connect the connectors to the RS485 communication interface:

D0	D̄	D-	A	Inverted bidirectional data line.
D1	D	D+	B	Bidirectional data line.
C				Optional connection which improves the communication performance.
GND				

Table 39

7.6.1 Baud Rate

The RHT Transmitter can be access via a Modbus-RTU network. The baud rate, parity and device address on the network need to be configured for this. The device responds to the read and write commands in its internal registers according to the specifications set out in this manual (see SERIAL COMMUNICATION chapter).

[nFG] bRud	Baud Rate	19.2	Modbus Register Value
	1200 bps	1.2	0
	2400 bps	2.4	1
	4800 bps	4.8	2
	9600 bps	9.6	3
	19200 bps	19.2	4
	38400 bps	38.4	5
	57600 bps	57.6	6
	115200 bps	115.2	7

Table 40

7.6.2 Parity

This parameter configures the parity for RHT *Climate* Transmitter communication on a Modbus-RTU network.

[nFG] Prty	Parity	Default: <i>nonE</i>	Modbus Register Value
	Without parity	<i>nonE</i>	0
	Even Parity	<i>EuEn</i>	1
	Odd Parity	<i>odd</i>	2

Table 41

7.6.3 Address

This parameter configures the address for RHT *Climate* Transmitter communication on a Modbus-RTU network. This parameter should be adjusted so that no two devices use the same address within a Modbus-RTU network.

[nFG] Rddr	Internet address	Min.	Max.	Unit	Default
		1	247	-	1

Table 42

7.7 GENERAL CONFIGURATION CYCLE

To access the parameters in this cycle, you must enter with the device password. The parameters in this cycle allow for selecting units of measure, adjusting atmospheric pressure, as well as offsets and digital filters for the sensor readings. Also in this cycle, you can enable configuration parameter protection and change the password.

7.7.1 Unit of Measure

The RHT *Climate* Transmitter can operate using the standard measurements in the International System of Measures (SI) or the English System of Measures (US). The table below shows the measurement unit adopted for each psychrometric property according to the value configured in this parameter.

CFG Unit	Units of measure	Default: SI	Modbus Register Value
	International System of Measures	SI	0
	English System of Measures	US	1

	SI	US
Temperature	°C	°F
Relative humidity	% RH	% RH
Dew point temperature	°C	°F
Partial vapor pressure	mbar	psi
Wet bulb temperature	°C	°F
Absolute humidity	g/m ³	gr/ft ³
Mixture ratio	g/kg	gr/lb
Specific enthalpy	kJ/kg	BTU/lb
Frost point temperature	°C	°F

Table 43

7.7.2 Atmospheric Pressure

The RHT *Climate* Transmitter uses the atmospheric pressure value to calculate some psychrometric properties. The default value used by this device is 1013 mbar (14.7 psi), but you can refine this information by inserting the value read by another reference instrument. Atmospheric pressure may vary according to altitude, or due to conditions of the process itself.

CFG PrES	Configures the atmospheric pressure value. This value is used for the calculation of psychrometric properties.	SI				US			
		Min.	Max.	Unit	Default	Min.	Max.	Unit	Default
		0	10000	mbar	1013	0	145	psi	14.7

Table 44

7.7.3 Digital temperature reading filter

A digital filter can be inserted at the temperature value read by the sensor, to reduce undesirable variations. The higher the time value configured in the digital filter, the slower the temperature reading response will be.

CFG FLt	Temperature sensor reading filter	Min.	Max.	Unit	Default
		0	300	s	60

Table 45

7.7.4 Digital relative humidity reading filter

A digital filter can be inserted at the relative humidity value read by the sensor, to reduce undesirable variations. The higher the time value configured in the digital filter, the slower the relative humidity reading response will be.

CFG FLrH	Humidity sensor reading filter	Min.	Max.	Unit	Default
		0	300	s	0

Table 46

7.7.5 Temperature reading offset

This parameter allows for correcting offset displacement in the temperature reading.

		SI				US			
		Min.	Max.	Unit	Default	Min.	Max.	Unit	Default
CFG OFt	Temperature reading offset	-5	5	°C	0	-9	9	°F	0

Table 47

7.7.6 Relative humidity reading offset

This parameter allows for correcting offset displacement in the relative humidity reading.

		Min.	Max.	Unit	Default
CFG OFrH	Humidity reading offset	-5	5	%	0

Table 48

7.7.7 Password

The **RHT Climate Transmitter** can be protected with a password, which ensures greater protection for the parameters defined in the device. This feature prevents unauthorized people from making changes to the transmitter's operating mode.

The configured factory default password is "1111". To change the password, you must enter the master password, which is formed as follows:

Master password = 9 followed by the last three digits forming the serial number.
--

After entering the master password, you can insert a new password.

		Min.	Max.	Unit	Default
CFG PASS	Password	0	9999	-	1111

Table 49

7.7.8 Parameter Protection

This parameter allows for enabling and disabling the protection of other parameters. When parameter protection is enabled, the **RHT Climate Transmitter** will allow for viewing the parameters but will not allow any change to the configured values. The device leaves the factor with parameter protection disabled.

CFG Prot	Parameter protection	Default: d5bL
	Parameter protection disabled	d5bL
	Parameter protection enabled	EnbL

Table 50

After configuring the transmitter, you can access this parameter and select the **EnbL** option to enable protection. As of this moment, the protection will be enabled.

To disable protection, you should access the **PASS** parameter and enter the configured password. Next you should access the **Prot** parameter and select the **d5bL** option. As of this moment, the protection will be disabled.

If the protection is enabled and you attempt to alter any parameter, the transmitter will show the **Prot** message on the display instead of the defined value.

7.8 INFORMATION CYCLE

In the information cycle, the RHT *Climate* Transmitter displays the serial number (**Sn**) and firmware version (**Firv**) of the device.



Figure 26

8 PARAMETERS MAP

PRIMARY CYCLE	Out1	Out2	AL1	AL2	bu22	IH1	d.AG	CO 1	CFG	
Temperature Relative humidity Selected variable	ERS	ERS	ERS	ERS	ERS	bct	F0u1	bAud	PASS	Sn
Maximum temperature Minimum temperature	radE	radE	radE	radE	radE	Cont	F0u2	Prty	Unit	Fin
Maximum relative humidity Minimum relative humidity	L-Lo	L-Lo	SPLo	SPLo	SPLo	F1	Flt	Addr	PrES	
Maximum dew point Minimum dew point	L-H1	L-H1	SPH1	SPH1	SPH1	F2	F1rH		FLt	
Wet bulb temperature	Err	Err	HYSct	HYSct	HYSct	Scr L1n3	FAL1		FLrH	
Absolute humidity			tOn	tOn	tOn		FAL2		DFt	
Frost point temp.			tOFF	tOFF	tOFF		Fb22		DFrH	
Enthalpy			bLA	bLA	bLA				PASS	
Partial vapor pressure			Err	Err	Err				Prot	
Mixture ratio			bu22	bu22						

Table 51

9 COMMUNICATION INTERFACES

9.1 CONNECTING TO A COMPUTER

The USB interface is used to CONFIGURE or MONITOR the device.

To CONFIGURE, you should use **SigNow** software or **SigNow** app, which offer features to create, view, save, and open configurations from the device or from files on your computer. The feature to save and open settings in files allows you to transfer settings between devices and create backups.

You can update the firmware (internal software) of the **RHT Climate Transmitter** via the USB interface.

To MONITOR, you can use any supervisory (SCADA) or laboratory software that supports Modbus RTU communication over a serial communication port. When connected to the USB interface of a computer, the **RHT Climate Transmitter** will be recognized as a conventional serial port (COM x).

You should use **SigNow** software or consult the Device Manager in the Windows Control Panel to identify the COM port assigned to the device. To MONITOR, refer to the Modbus memory mapping in the device communication manual and the supervisory software documentation.

To use the USB communication, follow the steps below:

- Download **SigNow** software (see [SIGNOW SOFTWARE](#) section) from our website.
- Install the software on the computer to be used. The USB drivers required for the operation of the communication will be installed along with the software.
- Connect the USB cable between the device and the computer. The device does not need to be powered. The USB interface will provide enough power for communication operation (other device functions may not operate).
- Run the software, configure the communication, and start the device recognition.



The USB interface IS NOT ISOLATED from the relay outputs and alarm outputs. Its purpose is temporary use during CONFIGURATION and MONITORING periods. For the safety of people and devices, it should only be used when the device is fully disconnected from the external power input.



In any other situation it is possible to use the USB interface, but it requires careful consideration by the people performing the installation.

For MONITORING over long periods and with the inputs and outputs connected, it is recommended to use the RS485 interface, available or optional in most of our devices.

9.2 CONNECTING TO ANDROID SMARTPHONE

9.2.1 CONNECTION VIA OTG CABLE

Smartphones Android with On the Go (OTG) technology can be directly connected to the device via the USB input. By connecting the OTG cable to the smartphone, you can recognize and configure your **RHT Climate Transmitter** by running **SigNow** app.

To use the USB communication, follow the steps below:

- Download **SigNow** app from the *Google Play Store*.
- Install the app on the smartphone to be used.
- Connect the USB cable between the device and the computer. The device does not need to be powered. The USB interface will provide enough power for communication operation (other device functions may not operate).
- Run the software, configure the communication, and start the device recognition (see [CONNECTING TO THE APP VIA OTG CABLE](#)).



If you position the cable end incorrectly, it is possible that the device will not be recognized by the application.

9.2.2 CONNECTION VIA MODBUS-TCP PROTOCOL

Android smartphones can also connect to the device via Modbus-TCP protocol (using a Modbus-TCP/Modbus-RTU Gateway). To do this, follow the steps below:

- Download **SigNow** app from the *Google Play Store*.
- Wait for the installation process to complete.
- Run the software, configure the Modbus-TCP communication, and start the device recognition (see [CONNECTING TO THE APP VIA MODBUS-TCP PROTOCOL](#)).

9.3 CONNECTING TO iOS SMARTPHONE

iOS smartphones can connect to the device via Modbus-TCP protocol (using a Modbus-TCP/Modbus-RTU Gateway). To do this, follow the steps below:

- Download **SigNow** app from the *App Store*.
- Wait for the installation process to complete.
- Run the software, configure the Modbus-TCP communication, and start the device recognition (see [CONNECTING TO THE APP VIA MODBUS-TCP PROTOCOL](#)).



iOS smartphones are not compatible with the OTG cable.

10 SERIAL COMMUNICATION

RHT *Climate* Transmitter can be recognized on a RS485 network with Modbus RTU protocol as a slave device. All the controller configurable parameters can be read and/or written via serial communication. Writing to Registers in Broadcast mode is also allowed, using address 0.

The available Modbus commands are as follows:

03 – Read Holding Register

05 – Write Single Coil

06 – Write Single Register

16 – Write Multiple Registers

10.1 HOLDING REGISTER TABLE

				SI			US		
PRIMARY CYCLE INDICATION REGISTERS									
Address	Description	R/W	Variable Type	Min.	Max.	Default	Min.	Max.	Default
0	Relative humidity value	RO	32 bits	0	10000	-	0	10000	-
1									
2	Dry bulb temperature value	RO	32 bits	-4000	10000	-	-4000	21200	-
3									
4	Wet bulb temperature value	RO	32 bits	-4000	10000	-	-4000	21200	-
5									
6	Dew point value	RO	32 bits	-9000	10000	-	-13000	21200	-
7									
8	Frost point value	RO	32 bits	-9000	10000	-	-13000	21200	-
9									
10	Specific enthalpy value	RO	32 bits	-4000	70000000*	-	-1800	30094500*	-
11									
12	Absolute humidity value	RO	32 bits	0	60000	-	0	26200	-
13									
14	Partial vapor pressure value	RO	32 bits	0	103500	-	0	1500	-
15									
16	Mixture ratio value	RO	32 bits	0	26000000*	-	0	182000000*	-
17									
18	Minimum humidity value	RO	32 bits	0	1000	-	0	1000	-
19									
20	Maximum humidity value	RO	32 bits	0	1000	-	0	1000	-
21									
22	Minimum temperature value	RO	32 bits	-4000	1000	-	-4000	2120	-
23									
24	Maximum temperature value	RO	32 bits	-4000	1000	-	-4000	2120	-
25									
26	Minimum dew point value	RO	32 bits	-9000	1000	-	-13000	2120	-
27									
28	Maximum dew point value	RO	32 bits	-9000	1000	-	-13000	2120	-
29									

Table 52

ANALOG OUTPUT OUT1 TRANSMISSION REGISTERS									
Address	Description	R/W	Variable Type	Min.	Max.	Default	Min.	Max.	Default
101	Transmission output type	RW	16 bits	0	1	0	0	1	0
102	Variable that will be transmitted	RW	16 bits	0	9	0	0	9	0
103	Upper retransmission limit input	RW	32 bits	The limits depend on the psychrometric property configured at address 102.					
104									
105	Lower retransmission limit input	RW	32 bits	The limits depend on the psychrometric property configured at address 102.					
106									
107	Value in case of error	RW	16 bits	0	1	1	0	1	1
108	Upper retransmission limit	RO	32 bits	The limits depend on the psychrometric property configured at address 102.					
109									
110	Lower retransmission limit	RO	32 bits	The limits depend on the psychrometric property configured at address 102.					
111									

Table 53

ANALOG OUTPUT OUT2 TRANSMISSION REGISTERS									
Address	Description	R/W	Variable Type	Min.	Max.	Default	Min.	Max.	Default
113	Retransmission output type	RW	16 bits	0	1	0	0	1	0
114	Variable that will be transmitted	RW	16 bits	0	9	0	0	9	0
115	Upper retransmission limit input	RW	32 bits	The limits depend on the psychrometric property configured at address 114.					
116									
117	Lower retransmission limit input	RW	32 bits	The limits depend on the psychrometric property configured at address 114.					
118									
119	Value in case of error	RW	16 bits	0	1	0	0	1	0
120	Upper retransmission limit	RO	32 bits	The limits depend on the psychrometric property configured at address 114.					
121									
122	Lower retransmission limit	RO	32 bits	The limits depend on the psychrometric property configured at address 114.					
123									

Table 54

FILTER AND UNIT SYSTEM REGISTERS									
Address	Description	R/W	Variable Type	Min.	Max.	Default	Min.	Max.	Default
125	Filter for humidity reading	RW	16 bits	0	300	60	0	300	60
126	Filter for temperature reading	RW	16 bits	0	300	60	0	300	60
127	Configuring units	RW	16 bits	0	1	0	0	1	0

Table 55

ALARM ALM1 OUTPUT REGISTERS									
Address	Description	R/W	Variable Type	Min.	Max.	Default	Min.	Max.	Default
133	Variable that will set off alarm	RW	16 bits	1	9	1	1	9	1
134	Type of alarm	RW	16 bits	0	5	0	0	5	0
135	High Setpoint input for alarm	RW	32 bits	The limits depend on the psychrometric property configured at address 133.					
136									
137	Low Setpoint input for alarm	RW	32 bits	The limits depend on the psychrometric property configured at address 133.					
138									
139	Alarm blocking	RW	16 bits	0	1	1	0	1	1
140	Alarm hysteresis	RW	16 bits	0	200	0	0	200	0
141	Alarm ON time	RW	16 bits	0	6500	0	0	6500	0
142	Alarm OFF time	RW	16 bits	0	6500	0	0	6500	0

ALARM ALM1 OUTPUT REGISTERS									
Address	Description	R/W	Variable Type	Min.	Max.	Default	Min.	Max.	Default
143	Determines the alarm status in case of sensor error	RW	16 bits	0	1	0	0	1	0
144	Determines buzzer activation	RW	16 bits	0	1	0	0	1	0
145	Setpoint High Alarm	RO	32 bits	The limits depend on the psychrometric property configured at address 133.					
146									
147	Setpoint Low Alarm	RO	32 bits	The limits depend on the psychrometric property configured at address 133.					
148									

Table 56

ALARM ALM2 OUTPUT REGISTERS									
Address	Description	R/W	Variable Type	Min.	Max.	Default	Min.	Max.	Default
150	Variable that will set off alarm	RW	16 bits	1	9	1	1	9	1
151	Type of alarm	RW	16 bits	0	5	0	0	5	0
152	Alarm Setpoint High Input	RW	32 bits	The limits depend on the psychrometric property configured at address 150.					
153									
154	Alarm Setpoint Low Input	RW	32 bits	The limits depend on the psychrometric property configured at address 150.					
155									
156	Alarm blocking	RW	16 bits	0	1	1	0	1	1
157	Alarm hysteresis	RW	16 bits	0	200	0	0	200	0
158	Alarm ON time	RW	16 bits	0	6500	0	0	6500	0
159	Alarm OFF time	RW	16 bits	0	6500	0	0	6500	0
160	Determines the alarm status in case of sensor error	RW	16 bits	0	1	0	0	1	0
161	Determines buzzer activation	RW	16 bits	0	1	0	0	1	0
162	Alarm Setpoint High	RO	32 bits	The limits depend on the psychrometric property configured at address 150.					
163									
164	Alarm Setpoint Low	RO	32 bits	The limits depend on the psychrometric property configured at address 150.					
165									

Table 57

ALARM ALM3 OUTPUT REGISTERS									
Address	Description	R/W	Variable Type	Min.	Max.	Default	Min.	Max.	Default
167	Variable that will set off alarm	RW	16 bits	1	9	1	1	9	1
168	Type of alarm	RW	16 bits	0	5	0	0	5	0
169	Alarm Setpoint High Input	RW	32 bits	The limits depend on the psychrometric property configured at address 167.					
170									
171	Alarm Setpoint Low Input	RW	32 bits	The limits depend on the psychrometric property configured at address 167.					
172									
173	Alarm blocking	RW	16 bits	0	1	1	0	1	1
174	Alarm hysteresis	RW	16 bits	0	200	0	0	200	0
175	Alarm ON time	RW	16 bits	0	6500	0	0	6500	0
176	Alarm OFF time	RW	16 bits	0	6500	0	0	6500	0
177	Alarm status in case of sensor error	RW	16 bits	0	1	0	0	1	0

ALARM ALM3 OUTPUT REGISTERS									
Address	Address	Address	Address	Address	Address	Address	Address	Address	Address
178	Determines buzzer activation	RW	16 bits	0	1	0	0	1	0
179	Alarm Setpoint High	RO	32 bits	The limits depend on the psychrometric property configured at address 167.					
180									
181	Alarm Setpoint Low	RO	32 bits	The limits depend on the psychrometric property configured at address 167.					
182									

Table 58

RS485 MODBUS COMMUNICATION PORT CONFIGURATION REGISTERS									
Address	Description	R/W	Variable Type	Min.	Max.	Default	Min.	Max.	Default
184	Baud rate	RW	16 bits	0	7	4	0	7	4
185	Parity	RW	16 bits	0	2	0	0	2	0
186	Slave address	RW	16 bits	1	247	1	1	247	1
187	Defines the variable of the third line of the HMI	RW	16 bits	0	7	0	0	7	0

Table 59

OFFSET REGISTERS									
Address	Description	R/W	Variable Type	Min.	Max.	Default	Min.	Max.	Default
192	Temperature Offset	RW	16 bits	-50	50	0	-90	90	0
193	Humidity Offset	RW	16 bits	-50	50	0	-50	50	0
200	Pressure value used for calculations	RW	16 bits	0	10000	1013	0	10000	147

Table 60

FORCING REGISTERS									
Address	Description	R/W	Variable Type	Min.	Max.	Default	Min.	Max.	Default
201	Enables output 1 forcing	RW	16 bits	0	1	0	0	1	0
202	Forced value for output 1	RW	16 bits	Limits depend on the analog output 1 configuration.					
203	Enables output 2 forcing	RW	16 bits	0	1	0	0	1	0
204	Forced value for output 2	RW	16 bits	Limits depend on the analog output 2 configuration.					
205	Enables forcing of alarm 1	RW	16 bits	0	1	0	0	1	0
206	Changes alarm status	RW	16 bits	0	1	0	0	1	0
207	Enables forcing of alarm 2	RW	16 bits	0	1	0	0	1	0
208	Changes alarm status	RW	16 bits	0	1	0	0	1	0
209	Turning backlight on	RW	16 bits	0	2	1	0	2	1
211	Enables buzzing forcing	RW	16 bits	0	1	0	0	1	0
212	Buzzer activation	RW	16 bits	0	1	0	0	1	0
213	Enables humidity forcing	RW	16 bits	0	1	0	0	1	0
214	Forced humidity value	RW	16 bits	0	1000	0	0	1000	0
215	Enables temperature forcing	RW	16 bits	0	1	0	0	1	0
216	Forced temperature value	RW	16 bits	-400	1000	0	-400	2120	0

Table 61



MINIMUM AND MAXIMUM PSYCHROMETRIC PROPERTIES AND SECOND KEY FUNCTION RESET REGISTERS									
Address	Description	R/W	Variable Type	Min.	Max.	Default	Min.	Max.	Default
217	Reset of all min. and max. values	RW	16 bits	0	1	0	0	1	0
221	Second function of key 	RW	16 bits	0	2	0	0	2	0
222	Second function of key 	RW	16 bits	0	1	0	0	1	0

Table 62

DEVICE TAG REGISTERS									
Address	Description	R/W	Variable Type	Min.	Max.	Default	Min.	Max.	Default
224	Device name string	RW	16 bits	ASCII	CHARACTER 2	CHARACTER 1			
225		RW	16 bits	ASCII	CHARACTER 4	CHARACTER 3			
226		RW	16 bits	ASCII	CHARACTER 6	CHARACTER 5			
227		RW	16 bits	ASCII	CHARACTER 8	CHARACTER 7			
228		RW	16 bits	ASCII	CHARACTER 10	CHARACTER 9			
229		RW	16 bits	ASCII	CHARACTER 12	CHARACTER 11			
230		RW	16 bits	ASCII	CHARACTER 14	CHARACTER 13			
231		RW	16 bits	ASCII	CHARACTER 16	CHARACTER 15			
232		RW	16 bits	ASCII	CHARACTER 18	CHARACTER 17			
233		RW	16 bits	ASCII	CHARACTER 20	CHARACTER 19			

Table 63

SENSOR LINEARIZATION REGISTERS									
Address	Description	R/W	Variable Type	Min.	Max.	Default	Min.	Max.	Default
234	Enables temperature linearization	RW	16 bits	0	1	0	0	1	0
235	Real temperature value 1	RW	16 bits	-400	1000	0	-400	2120	0
236	Target temperature value 1	RW	16 bits	-400	1000	0	-400	2120	0
237	Real temperature value 2	RW	16 bits	-400	1000	0	-400	2120	0
238	Target temperature value 2	RW	16 bits	-400	1000	0	-400	2120	0
239	Real temperature value 3	RW	16 bits	-400	1000	0	-400	2120	0
240	Target temperature value 3	RW	16 bits	-400	1000	0	-400	2120	0
241	Real temperature value 4	RW	16 bits	-400	1000	0	-400	2120	0
242	Target temperature value 4	RW	16 bits	-400	1000	0	-400	2120	0
243	Real temperature value 5	RW	16 bits	-400	1000	0	-400	2120	0
244	Target temperature value 5	RW	16 bits	-400	1000	0	-400	2120	0
245	Enables humidity linearization	RW	16 bits	0	1	0	0	1	0
246	Real humidity value 1	RW	16 bits	0	1000	0	0	1000	0
247	Target humidity value 1	RW	16 bits	0	1000	0	0	1000	0
248	Real humidity value 2	RW	16 bits	0	1000	0	0	1000	0
249	Target humidity value 2	RW	16 bits	0	1000	0	0	1000	0
250	Real humidity value 3	RW	16 bits	0	1000	0	0	1000	0
251	Target humidity value 3	RW	16 bits	0	1000	0	0	1000	0
252	Real humidity value 4	RW	16 bits	0	1000	0	0	1000	0
253	Target humidity value 4	RW	16 bits	0	1000	0	0	1000	0
254	Real humidity value 5	RW	16 bits	0	1000	0	0	1000	0
255	Target humidity value 5	RW	16 bits	0	1000	0	0	1000	0

Table 64

DEVICE INFORMATION REGISTERS			
Address	Description	R/W	Variable Type
300	High serial number	RO	16 bits
301	Low serial number	RO	16 bits
302	Firmware version	RO	16 bits
303	Release version	RO	16 bits
304	ID	RO	16 bits
305	Informs the device model	RO	16 bits

Table 65

DIAGNOSTIC REGISTERS		
Address	bit	Description
341	0	-
	1	Analog output 1 in overload.
	2	Analog output 2 in overload.
	3	Alarm 1 output status.
	4	Alarm 2 output status.
	5	Alarm 1 condition status.
	6	Alarm 2 condition status.
	7	Buzzer status in alarm 1.
	8	Buzzer status in alarm 2.
	9	Buzzer status.
	10	Alarm 1 forcing status.
	11	Alarm 2 forcing status.
	12	Analog output 1 forcing status.
	13	Analog output 2 forcing status.
342	0	Sensor error.
	1	Error in water vapor saturation pressure.
	2	Error in water vapor pressure.
	3	Error at dew point.
	4	Error in absolute humidity.
	5	Error in mixture ratio.
	6	-
	7	-
	8	Error in wet bulb temperature.
	9	Error in specific enthalpy.
	10	-
	11	Error in frost point.
343	1	Input values for retransmission limits of output 1 out of range.
	2	Input values for retransmission limits of output 2 out of range.
	3	Input values for alarm 1 setpoints out of range.
	4	Input values for alarm 2 setpoints out of range.
	5	Input values for alarm 3 setpoints out of range.

Table 66

The registers 103 to 106, 115 to 118, 135 to 138, 152 to 155 and 169 to 172 shall be used to enter the values of their respective parameters. If they are within limits, the device will automatically pass these values to registers 108 to 111, 120 to 123, 145 to 148, 162 to 165 and 179 to 182, which show the values considered during the operation. If the limits were extrapolated, this condition will be signaled in the diagnostic register 343.

For 32-bit data, the two registers that compose them must be read and/or written for the values to be updated.

The values of the 32-bit registers are available in little-endian with byte swap format, i.e., the first 16-bit register corresponds to the least significant part and the second one corresponds to the most significant part. All 16-bit registers are available as big-endian.

11 SIGNOW SOFTWARE AND APP

11.1 SIGNOW SOFTWARE

SigNow software is the main tool for configuring, downloading, and analyzing data from the **RHT Climate Transmitter**. It allows you to use all the features of the device, communicating through the USB interface.

To install **SigNow**, just download and run the **SigNowSetup.exe** file, available on our website.

This manual describes the generic functionalities of the software. For detailed instructions on setting up other devices and operating certain tools, you should check the specific operation manual. The software and its respective manual can be downloaded for free in the Download Area of our website www.novusautomation.com.

11.2 SIGNOW APP

SigNow app is the ideal tool for the daily use of the **RHT Climate Transmitter**. With our app, you can easily monitor or download data from your smartphone. It is compatible with both Android and iOS devices, making it accessible to everyone.

SigNow app can be downloaded for free from *Google Play Store* or *App Store*.

To configure the device through the Android app, you must connect it to the smartphone via an OTG cable (see [CONNECTION VIA AN OTG CABLE](#) section).

To configure the device through the iOS app, you must connect it to the smartphone via a Modbus-TCP connection (see [CONNECTING TO iOS SMARTPHONE](#) section). iOS smartphones **are not** compatible with OTG technology.



To communicate via Modbus-TCP protocol, it is necessary to use a Modbus-TCP/Modbus-RTU Gateway.

11.3 STARTING SIGNOW

When running **SigNow**, the following screens will appear:



Figure 27

To communicate with the software, **RHT Climate Transmitter** must be connected to the computer and have the USB drivers previously installed (see [CONNECTING TO A COMPUTER](#) section). To communicate with the app, you must connect the device to the smartphone via an OTG cable (see [CONNECTING TO A SMARTPHONE](#) section).

Next you can click either **Configuration** or **Diagnostics**.

The **Create Configuration** option allows you to create a configuration. The device does not need to be connected. This configuration can be saved to a file for future use or be written to a connected device. The **Open Configuration** option, on the other hand, allows you to read an already created configuration file.

11.4 CONNECTING TO THE SOFTWARE

Once the software is running, it is possible to read a device. To do this, you must click **Configuration**, select the USB option, and then the connected device:

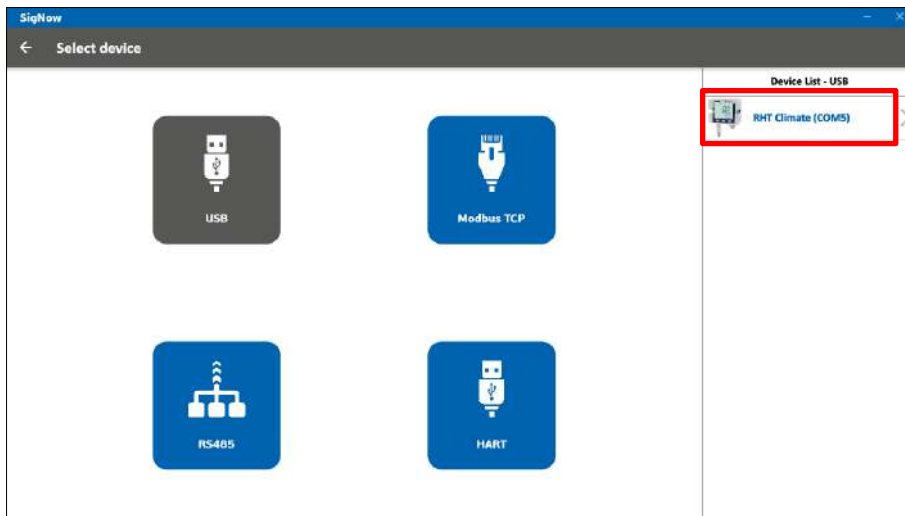

Figure 28

When you click on the **RHT Climate Transmitter** icon, the software will read the current device configuration and present all available features, as shown in the figure below:

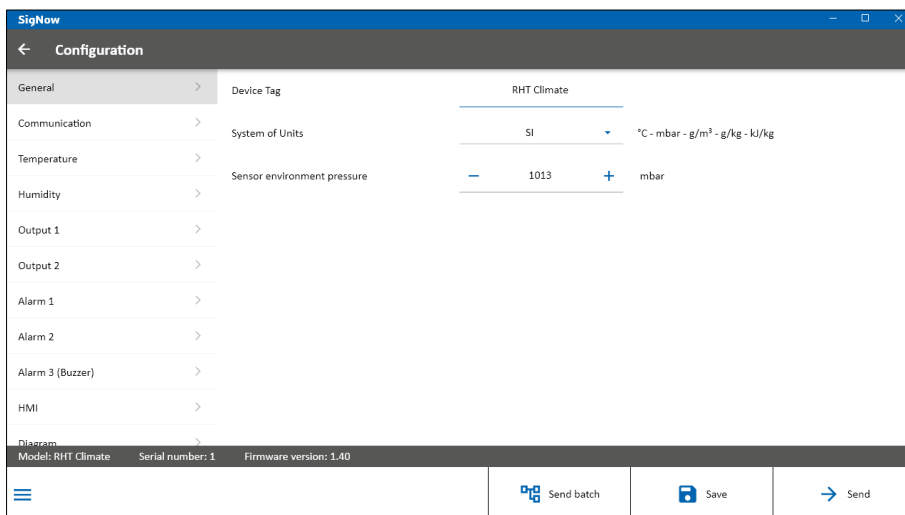



Figure 29

The configuration screen is divided into 12 sections: **General**, **Communication**, **Temperature**, **Humidity**, **Output 1**, **Output 2**, **Alarm 1**, **Alarm 2**, **Alarm 3 (Buzzer)**, **HMI**, **Diagram**, and **Firmware Update**. You can access these sections via the side menu. The **General** screen is the first screen to appear.

The bottom part of the screen displays information about the model, serial number, and firmware version, non-editable fields that are read by the software directly from the device. In addition, it displays the buttons , **Send Batch**, **Save**, and **Send**.

The  button compiles the following options:

- 1) **Manual**: Allows you to access the online manual for the device.
- 2) **Support**: Allows you to access the Technical Support page.
- 3) **Event Log**: Allows you to access a window that displays information about the settings made so far.
- 4) **Report**: Allows you to create a report with a .pdf extension, displaying all settings of the device.

11.5 CONNECTING TO THE APP VIA OTG CABLE

When using the **SigNow** app on an Android smartphone with an OTG cable (see [CONNECTION VIA OTG CABLE](#)), the device will be automatically recognized by the smartphone, as shown in the figure below:



Figure 30

Clicking the **Configuration** button on the home screen will take you directly to the device information screen:

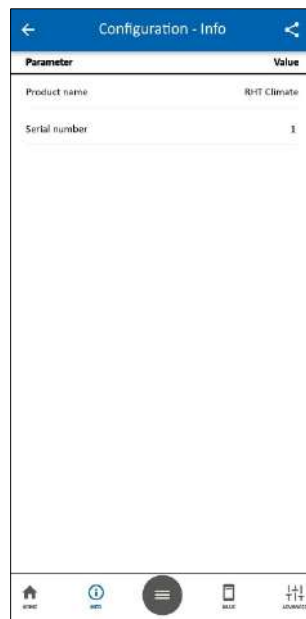



Figure 31

This screen, which can be accessed at any time by clicking the Info button, displays information about the product model and serial number, non-editable fields that are read by the app directly from the device. In addition, it displays the buttons , **Home**, **Basic**, and **Advanced**.

The  button compiles the following options:

- 1) **Manual:** Allows you to access the online manual for the device.
- 2) **Support:** Allows you to access the Technical Support page.
- 3) **Save:** Allows you to save the settings made so far.
- 4) **Send:** Allows you to send the settings to the device.

11.6 CONNECTING TO THE APP VIA MODBUS-TCP PROTOCOL

To establish a communication via Modbus-TCP protocol (either via an Android smartphone or an iOS smartphone), click on the **Configure** button on the main screen and then on **TCP/IP**:



Figure 32

To establish a Modbus-TCP connection, however, a Modbus-TCP/Modbus-RTU Gateway is required, which will act as an intermediary between the smartphone and the device. Once the connection has been established, the device will display the information screen:

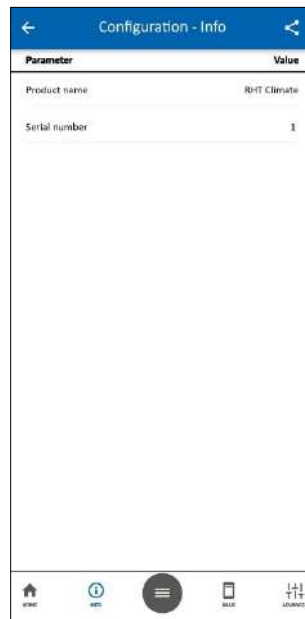



Figure 33

This screen, which can be accessed at any time by clicking the Info button, displays information about the product model and serial number, non-editable fields that are read by the app directly from the device. In addition, it displays the buttons , **Home**, **Basic**, and **Advanced**.

The  button compiles the following options:

- 1) **Manual:** Allows you to access the online manual for the device.
- 2) **Support:** Allows you to access the Technical Support page.
- 3) **Save:** Allows you to save the settings made so far.
- 4) **Send:** Allows you to send the settings to the device.

For more information on the TCP/IP connection mode of the application, refer to the **SigNow** manual, available on the product page on **NOVUS** website.

11.7 CONFIGURING THE DEVICE

The connection mode is slightly different between software and app, but the configuration and distribution of information and parameters is the same between both.

11.7.1 GENERAL / BASIC

This screen allows you to view general device information. The name of the screen changes between software (called **General**) and app (called **Basic**):

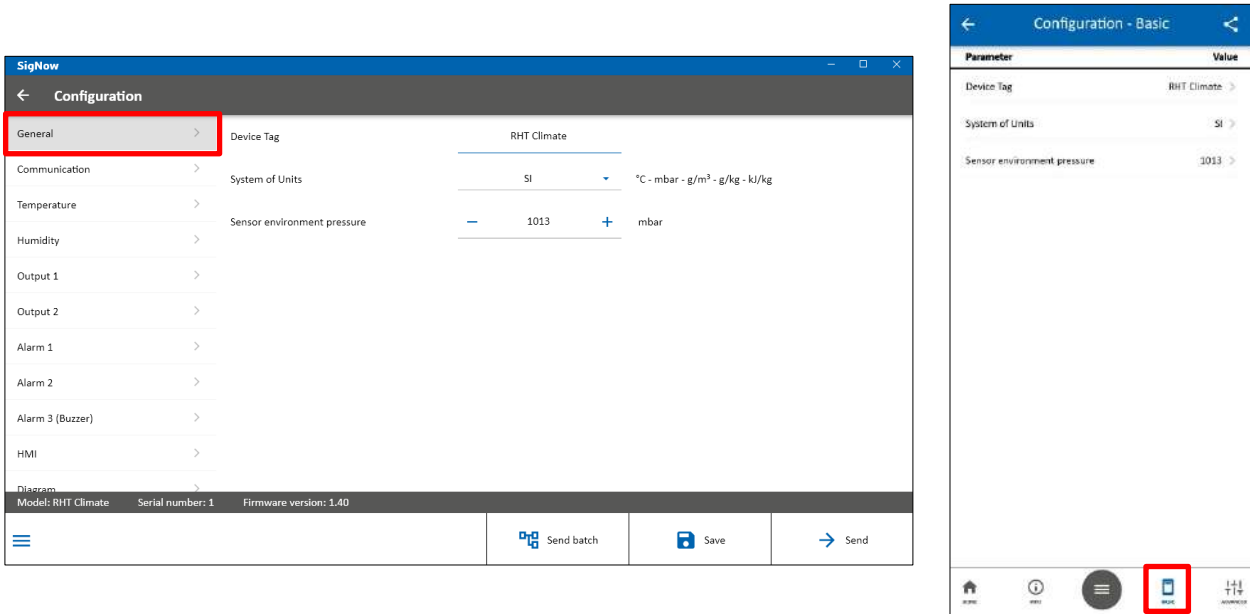

Figure 34

In the **Device Tag** field, you can assign a name to the device to be configured. This helps make the device easily identifiable within a network with multiple devices.

In the **System of Units** field, you can select the International System of Units (**SI**) or the American System of Units (**US**) (see [GENERAL CONFIGURATION CYCLE](#) section).

In the **Sensor environment pressure**, **RHT Climate Transmitter** allows you to set the atmospheric pressure. The device leaves the factory configured with a pressure value equivalent to atmospheric pressure at sea level. The values of the psychrometric properties calculated by the **RHT Climate Transmitter** can change depending on the pressure. In high altitude locations or in pressurized environments, you must adjust the value of this parameter. This way, **RHT Climate Transmitter** can use it in its compensation algorithms.

11.7.2 COMMUNICATION

This screen allows you to configure the communication parameters of the device:

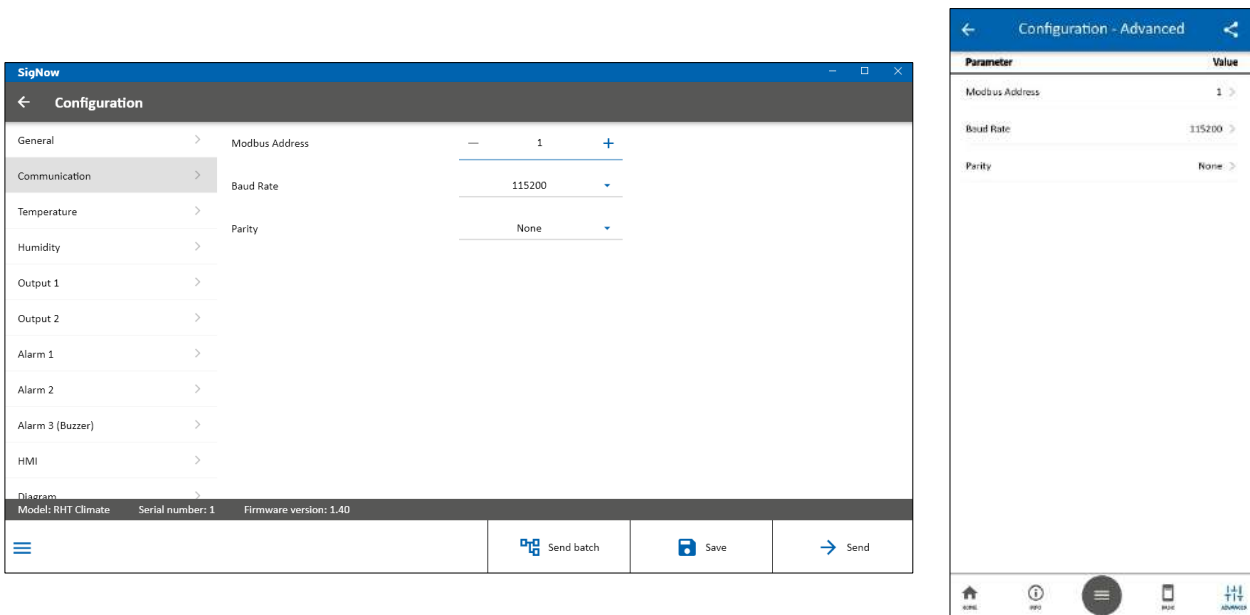

Figure 35

For the **RHT Climate Transmitter** to be recognized as a slave device in an RS485 Modbus network, you need to set a unique **Modbus Address** on the network, as well as the **Baud Rate** and **Parity**.

11.7.3 TEMPERATURE

This screen allows you to configure the parameters for the temperature sensor:

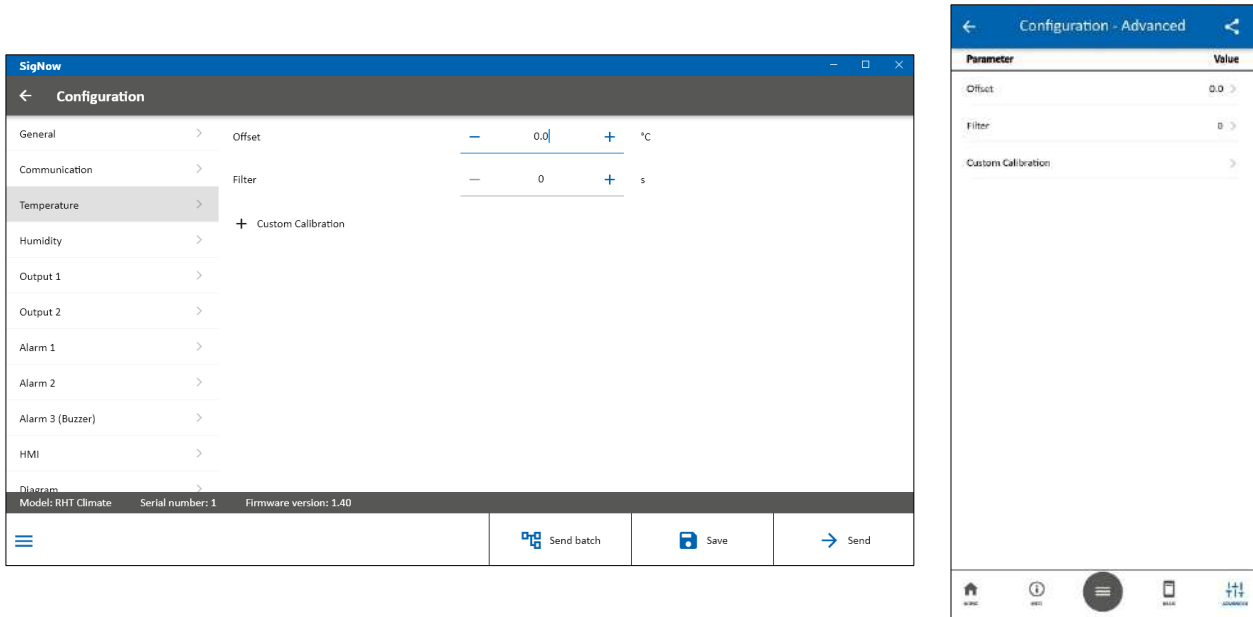

Figure 36

To read the temperature, the device provides **Offset** and **Filter** settings. With these features you can make small corrections to the sensor readings and slow down the response speed of the sensor.

For greater sensor accuracy, **RHT Climate Transmitter** has a **Custom Calibration** function that allows you to enter up to 5 temperature points. For more details about this feature, see the **SigNow** manual.

11.7.4 RELATIVE HUMIDITY

This screen allows you to configure the parameters for the relative humidity sensor:

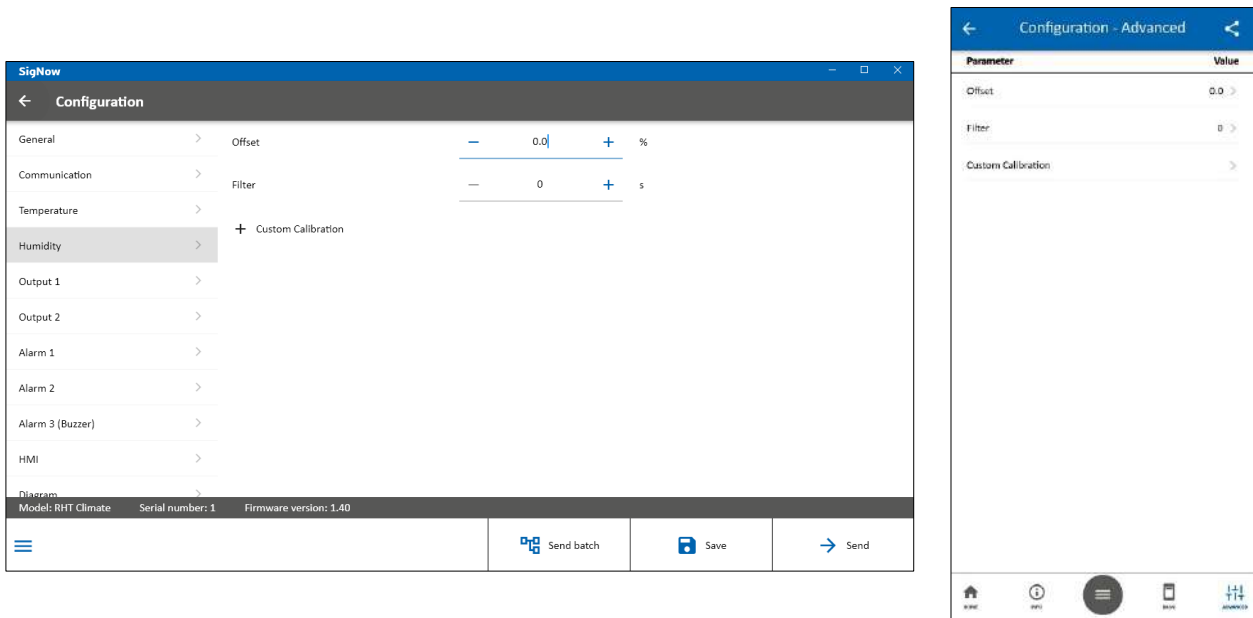

Figure 37

To read the relative humidity, the device provides **Offset** and **Filter** settings. With these features you can make small corrections to the sensor readings and slow down the response speed of the sensor.

For greater sensor accuracy, **RHT Climate Transmitter** has a **Custom Calibration** function that allows you to enter up to 5 temperature points. For more details about this feature, see the **SigNow** manual.

11.7.5 OUTPUTS 1 AND 2

The screens for the **Output 1** and **Output 2** sections are identical and allow you to configure their respective outputs, as shown in the example for **Output 1**:

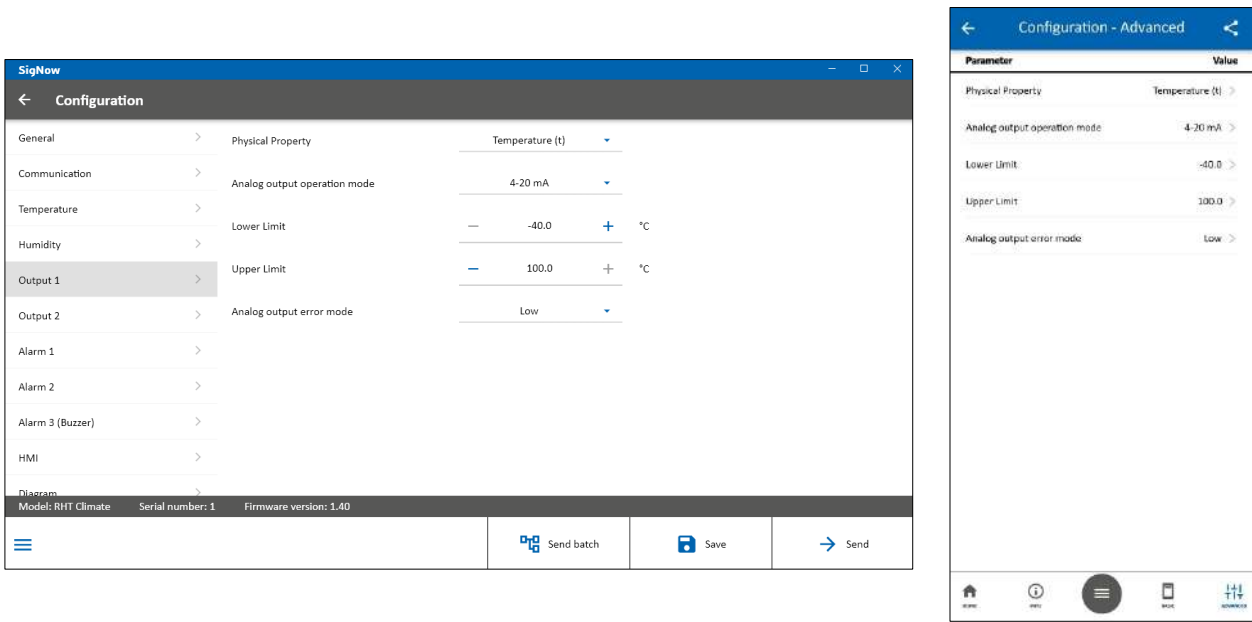

Figure 38

In the **Physical Property** field, you can select the psychrometric property to be transmitted by the output. The **Analog Output Operation Mode** function allows you to select the electrical standard to be used for transmission: 0-10 V or 4-20 mA. The electrical output signal will be proportional to the selected magnitude, respecting the values set in the parameters **Lower Limit** and **Upper Limit**.

In case of a sensor failure, the quantity to be transmitted by the analog output will go into error mode, as configured in the **Analog Output Error Mode** parameter. For the error condition, you must select the **High** or **Low** status:

MODE	ERROR MODE	
	LOW	HIGH
0-10 V	0 V	10 V
4-20 mA	3.6 mA	21.0 mA

Table 67

11.7.6 ALARMS 1 AND 2

The screens for the **Alarm 1** and **Alarm 2** sections are identical and allow you to configure their respective outputs, as shown in the example for **Alarm 1**:

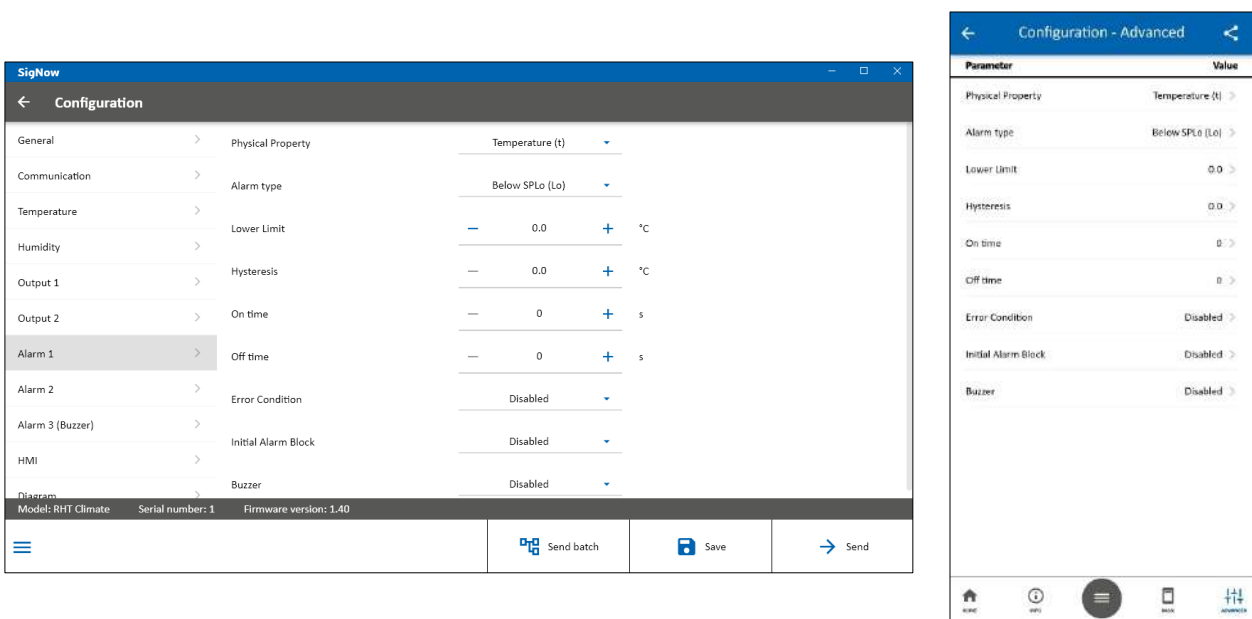

Figure 39

The alarm output can be timed using the parameters **On Time** and **Off Time**.

If the device is configured with alarm **L**, **H**, **L--H** or **-LH-**, the parameter **Error Condition** allows you to configure the status of the alarm output in case of temperature and relative humidity sensor failure. Therefore, the output will be turned on or off according to the value set in these parameters.

In some applications, it may be necessary to disregard alarms when turning the device on. A typical example refers to an application where you want to keep a refrigerated environment. If the alarm is set to activate below -10 °C or above 2 °C, it will trigger if the initial room temperature is 25 °C at the time **RHT Climate Transmitter** is turned on. To block this initial triggering, you can enable the **Initial Alarm Block** parameter. With initial block enabled, the device must reach a non-alarm condition for an alarm event to trigger the output.

It is also possible to link the activation of the buzzer to each alarm output. In this way, whenever the alarm output is on, the buzzer will be activated, respecting the timings. To link the buzzer to the alarm output, you must enable the **Buzzer** parameter⁵.

The buzzer settings are like those for alarms 1 and 2.

11.7.7 HMI

This screen allows you to configure the parameters for the display and keypad features⁶:

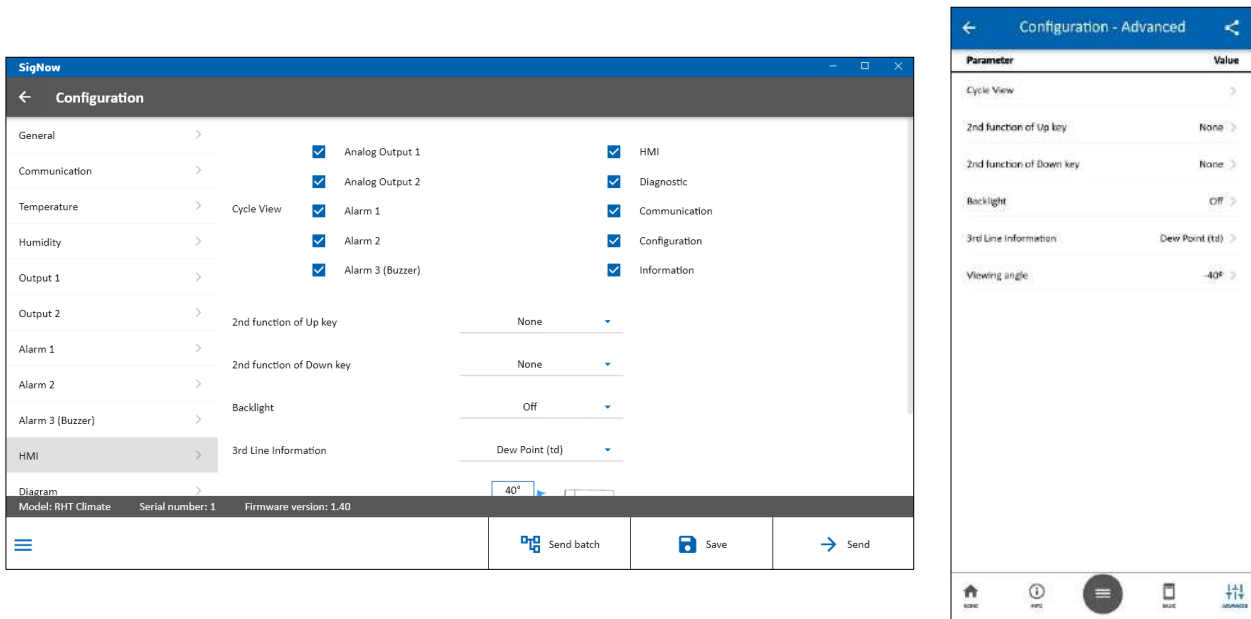



Figure 40

On this screen, you can:

- Select the configuration cycles that will be visible on the HMI.
- Set the second function of keys  and .
- Select the **Backlight** operation mode.
- Define the quantity to be shown on the third line of the display.
- Adjust the display contrast.

When navigating the configuration screens of **RHT Climate Transmitter** via keyboard, you can access only the cycles that are enabled by **SigNow**. In the example picture below, you can see only the selected screens:

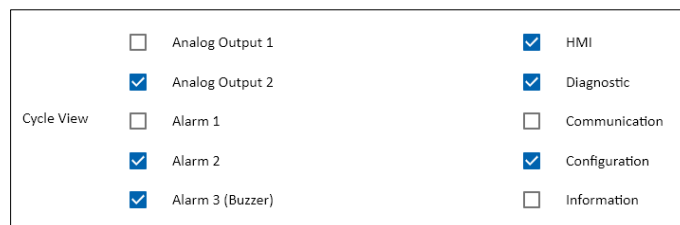





Figure 41

The  and  keys of the device, in addition to their function of incrementing, decrementing, and selecting options, can take on a second function if you configure the parameters **2nd Function of Up Key** and **2nd Function of Down Key**.

⁵ Function available only for LCD models.

⁶ Function available only for LCD models.

The  key can have the following functions:

- No action.
- Disable buzzer.
- Disable buzzer and alarm output.

If you configure the second key  function to disable the buzzer, and, during an alarm, you press this key (long press), the buzzer will be muted but the alarm output will still be activated.

If you configure the second key  function to disable the buzzer and the alarm output, and, during an alarm, you press this key (long press), the buzzer will be muted and the alarm output will be disabled.

The buzzer and alarm output will be reactivated only if the **RHT Climate Transmitter** goes into a non-alarm condition and then returns to an alarm condition.

The  key can have the following functions:

- No action.
- Clear minimum and maximum values.

If you configure the second key  function to reset minimum and maximum values and, while viewing any minimum and maximum display screen, press this key (long touch), the minimum and maximum values of all psychrometric properties of the device will be reset.

The **Backlight** mode of operation can operate in the following ways:

- **Off:** The display backlight remains off.
- **On:** The display backlight remains on.
- **On for 15 s:** The backlight turns on whenever a key is pressed. If you don't press any key after 15 seconds, the backlight will automatically turn off.

The display allows you to adjust five levels of contrast, which makes it easier to visualize the display information from different viewing angles. To select the best angle, click on the desired angle value.

You can also define the quantity to be shown on the third line of the display, according to the options shown in the parameter **3rd Line Information**.

11.7.8 DIAGRAM

This screen shows information about the display and the basic electrical connections of the device:

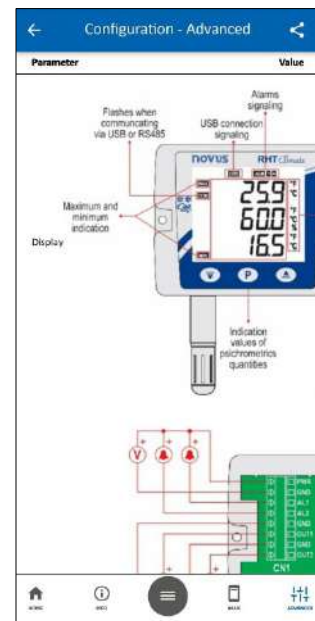
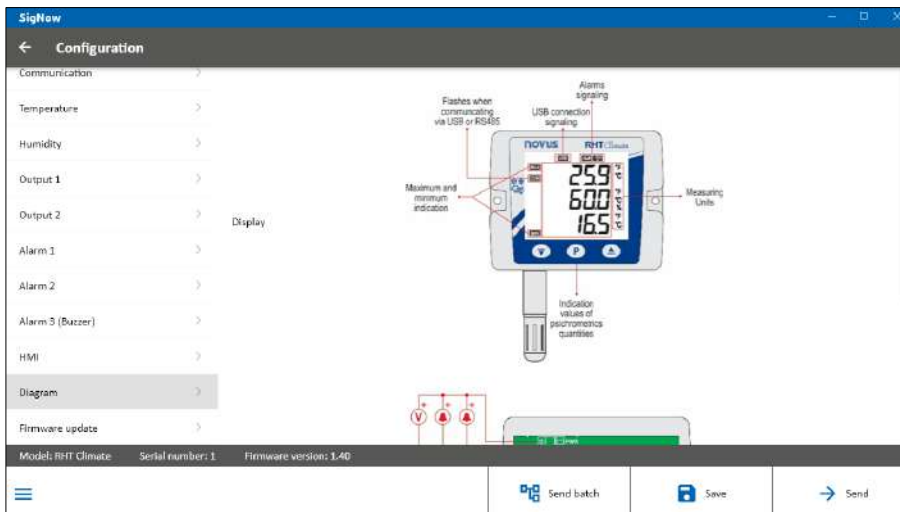

Figure 42

11.7.9 FIRMWARE UPDATE

This screen allows you to update the firmware of the device:

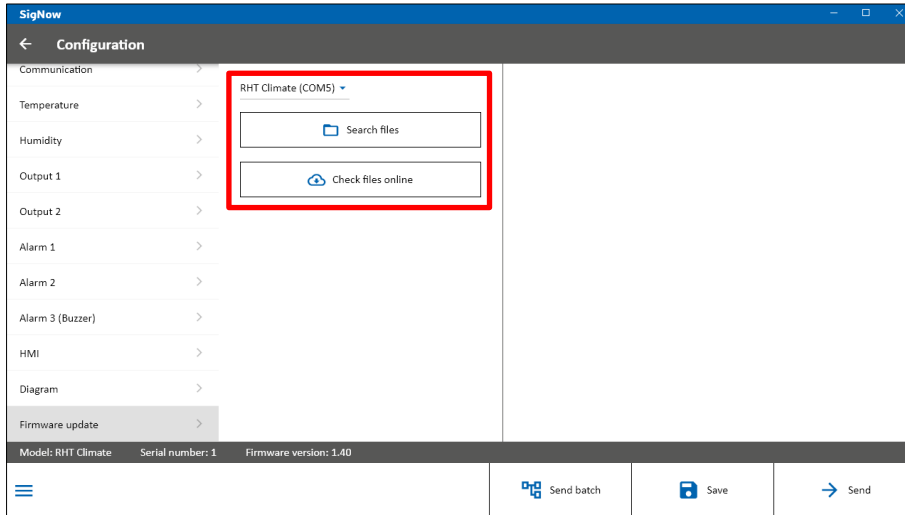

Figure 43

The firmware update process is standard for all **NOVUS** devices linked to **SigNow** and can be viewed in detail in the software manual. To update the firmware through the application, however, you must click on the **Firmware** button, located on the start screen, and then proceed in the same way, searching for the desired file or checking online for its existence.



Figure 44

11.8 PERFORMING THE DIAGNOSTICS

From the **SigNow** home screen, you can access the **Diagnostics** screen and monitor some device status. The information update interval is 1 second. In this section you can verify the correct operation of the **RHT Climate Transmitter** by forcing the temperature and relative humidity readings, the alarm outputs, and the buzzer.

To access it, you must click **Diagnostics**, select the **USB** option, and then the connected device:

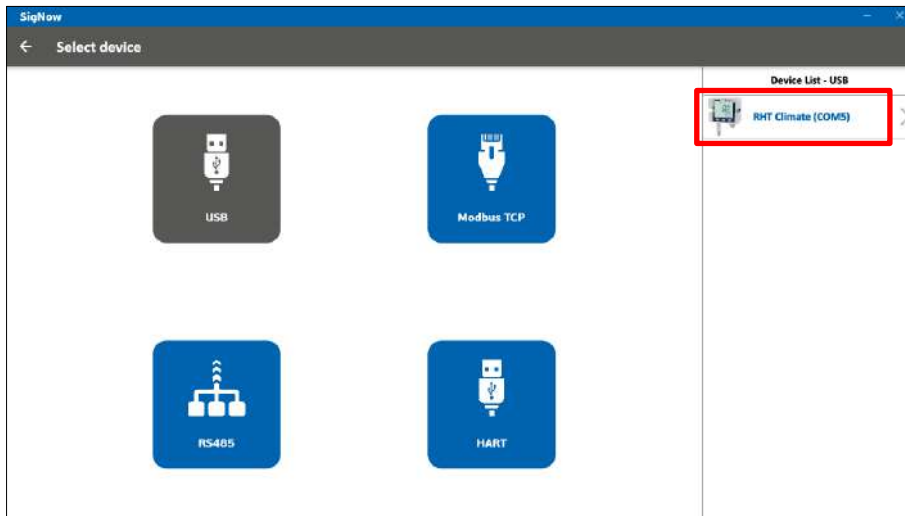

Figure 45

The above process should be disregarded if you are using **SigNow** app, since the app performs device recognition from the first moment of connection.

Then both the software and the app will read the current device configuration and present all available features, as shown in the figure below:

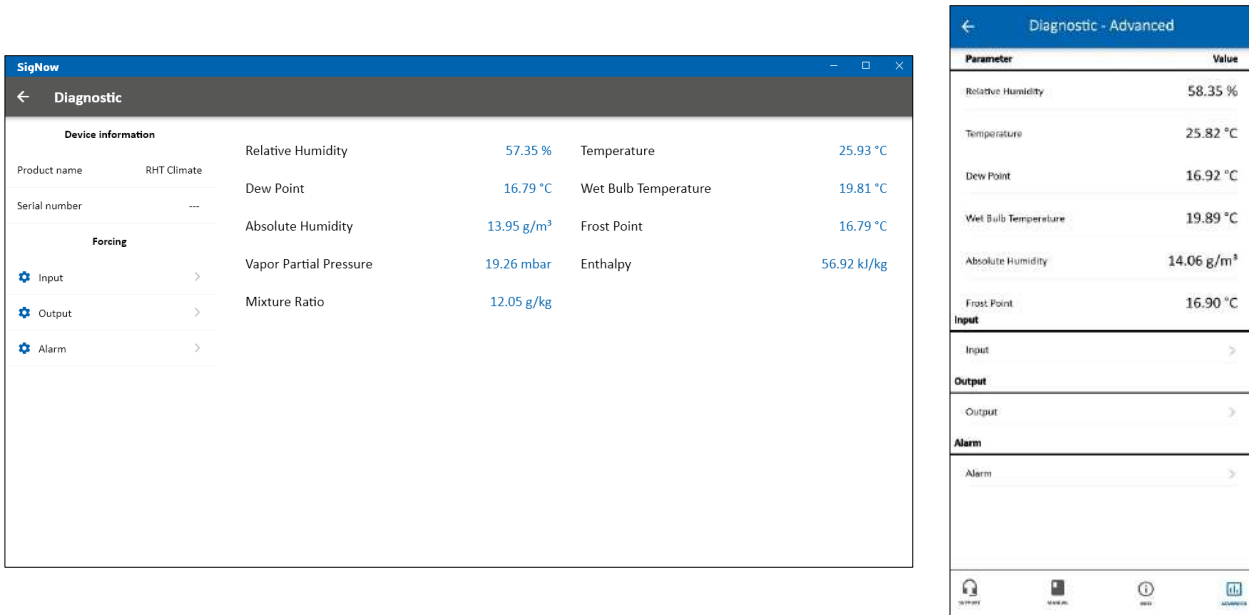

Figure 46

The diagnostic displays information about the instantaneous value of the psychrometric properties, presented to two decimal places. Additionally, accessing the **Input**, **Output**, and **Alarm** sections, available in the side menu, also allows you to force values with one decimal place.

In the **Input** section, you can enter the desired value and use the activation key (→) to force temperature or relative humidity values.

In the **Output** section, you can enter the desired value and use the activation key (→) to force voltage or current values for outputs 1 and 2. The transmission mode (0-10 V or 4-20 mA) that will be forced on the outputs depends on the configuration applied to each of them (see [OUTPUTS 1 AND 2](#) section).

You can also force an error value to be transmitted by checking the **Min. Error** and **Max. Error**. These values depend on the mode (0-10 V or 4-20 mA) configured for each output.

In the **Alarm** section, you can force the alarm outputs to be on or off, as shown in the figure below:

Alarm Output 1	<input checked="" type="checkbox"/>	Turns On	<input type="checkbox"/>	Turns off	Status: Forced-on
Alarm Output 2	<input type="checkbox"/>	Turns On	<input checked="" type="checkbox"/>	Turns off	Status: Forced-off
Buzzer	<input type="checkbox"/>	Turns On	<input checked="" type="checkbox"/>	Turns off	Status: Forced-off

Figure 47

In some cases, it is possible that an alarm output is activated due to an alarm condition. Thus, it may be desirable to force the off status to be able to identify some failure in the wiring or in the configuration of the device.

12 TECHNICAL SPECIFICATIONS

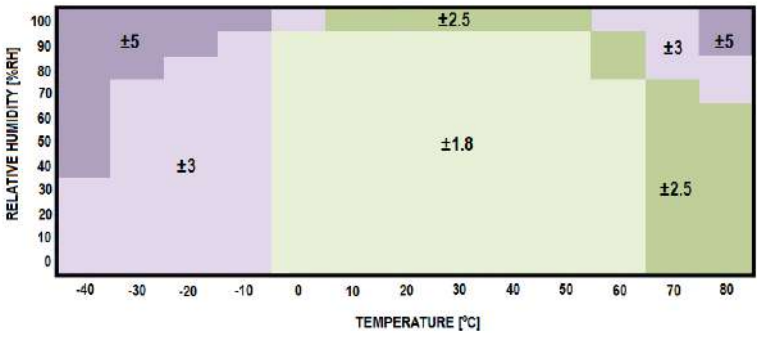
SPECIFICATIONS	RHT <i>Climate</i> Transmitter											
Humidity measurement	Measurement range: <ul style="list-style-type: none"> Configurable: Between 0 % RH and 100 % RH (no condensing). Configurable: Between -90 °C at 100 °C in dew point. 											
	Response time (1/e (63 %)): < 4 seconds @25 °C (with air moving at 1 m/s and polyamide tip)											
Temperature measurement	Measuring Range: <ul style="list-style-type: none"> DM model: -40 °C to 100 °C (-40 to 212 °F). WM model: -40 °C to 60 °C (-40 to 140 °F). 											
	Response time (1/e (63 %)): < 5 seconds @25 °C (with air moving at 1 m/s and polyamide tip).											
Accuracy	<ul style="list-style-type: none"> Temperature¹: ± 0.4 °C (0 °C to 60 °C). Relative Humidity: See image below. 											
	 <p>Other error sources:</p> <table border="1"> <thead> <tr> <th>ERROR SOURCE</th> <th>HUMIDITY</th> <th>TEMPERATURE</th> </tr> </thead> <tbody> <tr> <td>Degradation over time</td> <td>< 0.5 % RH / year</td> <td>< 0.05 °C / year</td> </tr> <tr> <td>Reproducibility</td> <td>Included in the figure above</td> <td>± 0.1 °C</td> </tr> <tr> <td>Thermal drift</td> <td>0.05 % RH / °C</td> <td>Does not apply</td> </tr> </tbody> </table> <p>Note 1: When performing a transmitter calibration through a Metrology Lab, it is necessary to consider that the calibration uncertainty must be added to the product accuracy.</p>	ERROR SOURCE	HUMIDITY	TEMPERATURE	Degradation over time	< 0.5 % RH / year	< 0.05 °C / year	Reproducibility	Included in the figure above	± 0.1 °C	Thermal drift	0.05 % RH / °C
ERROR SOURCE	HUMIDITY	TEMPERATURE										
Degradation over time	< 0.5 % RH / year	< 0.05 °C / year										
Reproducibility	Included in the figure above	± 0.1 °C										
Thermal drift	0.05 % RH / °C	Does not apply										
Operating temperature of the transmitter	<ul style="list-style-type: none"> Operating temperature: -40 to 60 °C (-40 to 140 °F). Storage temperature: -40 to 70 °C (-40 to 158 °F). 											
Power supply	<ul style="list-style-type: none"> Power supply via PWR terminals: 12 Vdc to 30 Vdc. Power supply via USB cable: 4.75 Vdc to 5.25 Vdc. Internal protection against power supply voltage reverse polarity.											
Maximum power supply current	< 70 mA ± 10 % @ 24 Vdc											
OUT1 Output OUT2 Output	They may be configured independently to operate with signals 0-10 V or 4-20 mA. <ul style="list-style-type: none"> 0-10 V: <ul style="list-style-type: none"> Maximum current: 2 mA Resolution: 0.003 V 4-20 mA: <ul style="list-style-type: none"> 500 R maximum load Resolution: 0.006 mA 											
AL1 Alarm AL2 Alarm	<ul style="list-style-type: none"> Channel N 30 V / 200 mA type output. Protection against overcurrent > 200 mA. Overcurrent protection reset time: 5 seconds. 											
Buzzer sound intensity	Approximately 70 dB at a distance of 1 m.											
Protection rating	<ul style="list-style-type: none"> Electronic module housing: IP65. 											

SPECIFICATIONS	RHT <i>Climate</i> Transmitter
	<ul style="list-style-type: none"> • Sensor capsule: IP40 or IP20, according to the models: Sintered PTFE (with the device) or polyamide (optional).
Cable entrance	Cable gland PG7.
Housing	ABS+PC
Configurator Software	<ul style="list-style-type: none"> • SigNow software, compatible with Windows 10 or higher. • SigNow app, compatible with Android and iOS smartphones.
Certifications	<p>CE Mark</p> <p>This is a Class A product. In a domestic environment, this product may cause radio interference in which case the user may be required to take adequate measures.</p>

Table 68

13 WARRANTY

Warranty conditions are available on our website www.novusautomation.com/warranty.

14 APPENDIX 1 – NOTIONS ABOUT PSYCHROMETRY

Psychrometry is the study of thermodynamic properties of dry air and water vapor mixtures. Obtaining the psychrometric properties is crucial in the psychrometric processes of air conditioning, refrigeration, cooling and freezing, air humidification and dehumidification, drying and dehydration of humid devices, as well as in environmental and meteorological control.

The psychrometric properties provided by the RHT *Climate Transmitter* are:

- Dry Bulb Temperature
- Relative Humidity
- Dew Point Temperature
- Wet Bulb Temperature
- Absolute Humidity
- Frost Point Temperature
- Specific Enthalpy
- Partial Vapor Pressure
- Mixture Ratio

14.1 DRY BULB TEMPERATURE | [°C] OR [°F]

It is simply the temperature of the air and water vapor mixture surrounding the thermometer.

14.2 RELATIVE HUMIDITY | [%RH]

Relative humidity expresses the percentage of water vapor contained in a certain amount of air. When the air reaches 100% relative humidity, it will have reached its maximum water absorption capacity. In this condition, the air is said to be saturated and water vapor condensation starts to be evident on the surfaces surrounded by this mixture.

14.3 DEW POINT TEMPERATURE | [°C] OR [°F]

The dew point is defined as the temperature to which the air must be cooled for water condensation to begin, meaning for the air to be saturated with water vapor. At dew point temperature, the amount of water vapor present in the air is maximum.

The capacity to retain water by air is heavily dependent on temperature: warm air can retain more water. The dew point is typically used to represent the amount of water vapor in dry air or gas. At low humidity, changes in dew point temperature are greater than changes in relative humidity, allowing for greater measurement precision and control.

14.4 WET BULB TEMPERATURE | [°C] OR [°F]

The wet bulb temperature is measured by a thermometer with bulb covered by a mesh (usually cotton) that is submerged in a recipient containing distilled water. Water evaporation draws out heat from the bulb, making the wet bulb thermometer indicate a temperature lower than the ambient air. Evaporation consumes heat, causing cooling. This evaporation, and consequently the wet bulb temperature, is greater when the atmospheric air is drier, and is null when the atmosphere is saturated with water vapor (relative air humidity equal to 100%).

14.5 ABSOLUTE HUMIDITY | [G/M³] OR [GR/FT³]

Absolute humidity expresses the mass of water vapor contained in each volume. If all the water of one cubic meter of air is condensed in a vessel, this vessel will contain all the absolute humidity of that portion of air and the amount of condensed water can be weighed to quantify the absolute humidity.

14.6 FROST POINT TEMPERATURE | [°C] OR [°F]

The frost point temperature is the temperature to which air must be cooled, with constant pressure, to reach saturation (in relation to liquid water) and to settle in the form of frost on a surface.

14.7 SPECIFIC ENTHALPY | [KJ/KG] OR [BTU/LB]

It is the energy contained in moist air by the amount of dry air. For a given mass of air to occupy a given volume at a given pressure, this occurs at the expense of energy. The higher the relative air humidity, the higher its specific enthalpy will be.

14.8 PARTIAL VAPOR PRESSURE | [MBAR] OR [PSI]

The partial pressure of a gas in a gaseous mixture of ideal gases corresponds to the pressure that it would exert if it were occupying the whole container alone, at the same temperature as the ideal mixture. As such, the total pressure is calculated via the sum of partial pressures of the gases that make up the mixture.

14.9 MIXTURE RATIO | [G/KG] OR [GR/LB]

The mixture ratio is expressed as the ratio of the mass of water vapor per kilogram of dry air into any portion of the atmosphere separated for study. The mixture ratio varies with temperature, except if the temperature is lower than the dew point, or when the air is completely saturated with water vapor. In these conditions, the drop in temperature will cause forced water condensation.