



TELIK GARDO READER



USER GUIDE V1.0x D

NOVUS
We Measure, We Control, We Record

1	SAFETY ALERTS	3
2	INTRODUCTION	4
2.1	DEVICE.....	4
2.2	ANTENNA.....	4
2.3	SENSORS	4
3	INSTALLATION	5
3.1	ELECTRICAL INSTALLATION	5
3.1.1	INSTALLATION RECOMMENDATIONS	5
3.1.2	POWER SUPPLY CONNECTIONS.....	5
3.2	DIMENSIONS	5
3.2.1	TELIK GARDO.....	5
3.2.2	TELIK GARDO ANTENNA.....	5
3.2.3	TELIK GARDO SENSOR.....	6
3.3	MECHANICAL INSTALLATION.....	6
3.4	COMMUNICATION INTERFACES.....	6
3.4.1	USB INTERFACE	6
3.4.2	RS485 INTERFACE.....	6
4	HOW TO INSTALL THE CONFIGURATION SOFTWARE	7
4.1	INSTALL THE USB DRIVER	7
4.2	INSTALL THE CONFIGURATOR SOFTWARE.....	7
4.3	CONNECT THE DEVICE TO THE COMPUTER.....	7
5	HOW TO USE THE TELIK GARDO SOFTWARE	8
5.1	SOFTWARE INITIAL RUN.....	8
5.2	TELIK GARDO SOFTWARE INTERFACE	9
5.2.1	SOFTWARE VERSION	9
5.2.2	PANEL WITH CONFIGURATION FUNCTIONS.....	10
5.2.3	DISPLAYING TEMPERATURE DATA FOR THE SENSOR.....	10
5.2.4	SELECTION OF THE RELATED USB COMMUNICATION PORT	10
5.2.5	REAL-TIME DATA COLLECTION FUNCTION.....	10
5.2.6	FIRMWARE VERSION	11
5.2.7	START/STOP SENSOR READING.....	11
5.3	HOW TO CONFIGURE THE P1 SENSORID INTERFACE.....	11
5.4	HOW TO PERFORM A BASIC CONFIGURATION.....	13
5.5	HOW TO CONFIGURE THE ANTENNAS.....	13
5.6	HOW TO USE THE TOOLBAR	14
5.6.1	TOOLBAR.....	14
5.6.2	RF CTRL INTERFACE INSTRUCTIONS	15
5.6.3	FIRMWARE DOWNLOAD INTERFACE INSTRUCTIONS.....	15
6	MODBUS-RTU PROTOCOL	17
6.1	COMMANDS.....	17
6.2	REGISTERS TABLE.....	17
6.2.1	RELATIVE HUMIDITY INFORMATION (OPTIONAL)	18
7	TECHNICAL SPECIFICATIONS	19
7.1	CERTIFICATIONS	19
8	WARRANTY	21

1 SAFETY ALERTS

The following symbols are used on the equipment and throughout this manual to draw the user's attention to valuable information related to the safety and use of the equipment.

		
CAUTION Read the manual completely before installing and operating the equipment.	CAUTION OR HAZARD Risk of electric shock.	ATTENTION Material sensitive to static charge. Be sure to take proper precautions before handling it.

All safety recommendations appearing in this manual must be followed to ensure personal safety and prevent damage to the instrument or system. If the instrument is used in a manner other than that specified in this manual, the device safety protections may not be effective.

2 INTRODUCTION

Some of the main challenges for electric power distribution companies involve uninterrupted power supply and the need to meet the requirements of regulatory agencies regarding the quality of electricity supply.

Therefore, it is necessary to monitor the most critical components of power substations to ensure their integrity.

Since an unusual temperature rise can be seen as an early warning indicator of anomaly or asset degradation, **NOVUS** has launched the **Telik Gardo** kit, a remote temperature monitoring system that allows you to view information online and manage the maintenance process.

Using wireless temperature sensors, **Telik Gardo Reader** is easy to install and deploy. It can be integrated into any SCADA system or any cloud platform using an IoT Gateway.

2.1 DEVICE

This is the **Telik Gardo Reader**:



Figure 1

Ideal for DIN rail installation, the device allows you to collect data, read temperature information, and perform continuous monitoring of power substations.

2.2 ANTENNA

This is the **Telik Gardo Antenna**:

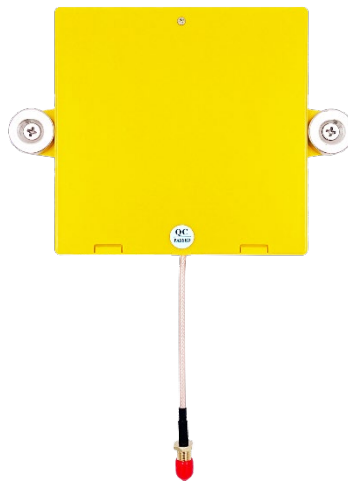

Figure 2

The antenna must be attached to the wall by using two screws or connected to the surface by using the magnets. Connected to the antenna, you must install the **Telik Gardo Cable**, which is 3 meters long.

2.3 SENSORS

These are the **Telik Gardo Sensors**:



Figure 3

The sensors must be installed close to the place to be monitored, fixed with a screw or cable ties. Since they are passive sensors, they do not require batteries.

3 INSTALLATION

3.1 ELECTRICAL INSTALLATION

3.1.1 INSTALLATION RECOMMENDATIONS

- Electronic and analog signal conductors must run through the plant separately from the output and supply conductors. If possible, in grounded conduits.
- The power supply for the electronic instruments must come from a proper instrumentation network.
- It is recommended to use RC FILTERS (noise suppressors) at contactor coils, solenoids, etc.
- In control applications, it is essential to consider what can happen when any part of the system fails. The internal devices of the equipment do not guarantee full protection.
- The electrical connections must be made with the connection terminals detached from the equipment. Before connecting them, make sure that the connections have been made correctly.

3.1.2 POWER SUPPLY CONNECTIONS

You must connect the source to the device, using the following identification:

P	Positive.
N	Negative / Neutral.
	Ground.

Table 1

3.2 DIMENSIONS

3.2.1 TELIK GARDO

The device has the following dimensions:

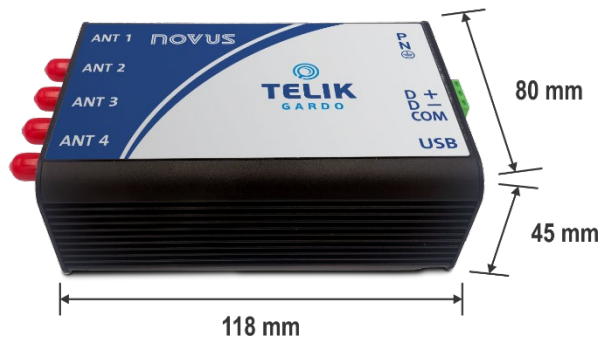

Figure 4

3.2.2 TELIK GARDO ANTENNA

The antenna has the following dimensions:

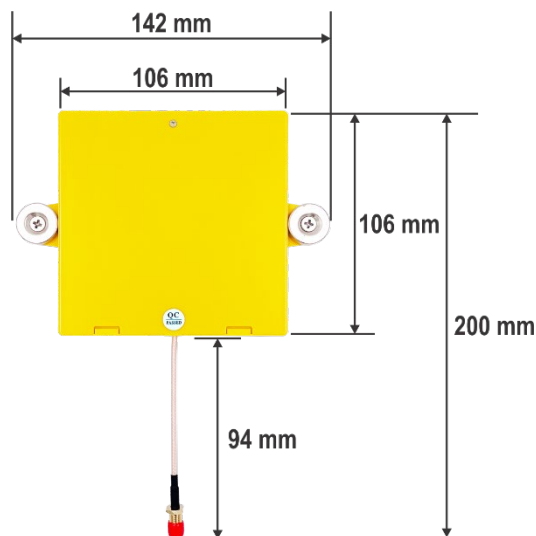

Figure 5

3.2.3 TELIK GARDO SENSOR

The sensor has the following dimensions:



Figure 6

3.3 MECHANICAL INSTALLATION

Telik Gardo Reader is intended for a 35 mm DIN rail mounting. You should use the fixing holes or the magnets to attach your antennas to the wall or desired surface. You can attach the sensors to the electrical panel or surface by using a screw or cable ties.

3.4 COMMUNICATION INTERFACES

3.4.1 USB INTERFACE

Telik Gardo Reader has a USB interface, located on the side of the device. The USB interface must be used to configure and perform device diagnostics via **Telik Gardo** software. To connect the device to a computer, you must use a micro-USB standard USB cable (not supplied).

Before installing the configuration software, you must install the USB interface drivers (see [HOW TO INSTALL THE CONFIGURATION SOFTWARE](#) chapter).

	The USB interface should be used temporarily to CONFIGURE and PERFORM DIAGNOSTICS of the device.
--	---

3.4.2 RS485 INTERFACE

Telik Gardo Reader has a RS485 interface, located on the side of the device. The RS485 interface can be configured to operate at the following speeds (Baud Rates): 1200, 2400, 4800, 9600, 19200, 38400, 57600, and 115200. In addition, it can be configured to operate with 1 or 2 Stop Bits and in the parities 8N1, 8N2, 8O1, or 8E1. All these parameters can be configured through the software.

The table below helps you to perform the RS485 communication interface connection:

D0	\bar{D}	D-	A	Inverted bidirectional data line.
D1	D	D+	B	Bidirectional data line.
COM				Optional connection that improves communication performance.
GND				

Table 2

More details on implementing a device network via RS485 can be found in the document "RS485 and RS422 basics", available at www.novusautomation.com.

4 HOW TO INSTALL THE CONFIGURATION SOFTWARE

Telik Gardo Reader is compatible with the **Telik Gardo** software, used to configure and monitor the device. To use it, you must follow the steps below.

4.1 INSTALL THE USB DRIVER

Install the USB driver to enable the computer you are using to recognize **Telik Gardo Reader** via the USB interface.

Simply double-click the file *CP210x_Universal_Windows_Driver*, available for download from **NOVUS'** product page. To complete the installation, follow the instructions that will appear on the screen.

4.2 INSTALL THE CONFIGURATOR SOFTWARE

Install **Telik Gardo** software to configure and perform data reading from **Telik Gardo Reader**. The software is compatible with Windows 10 and later versions.

Simply double-click the file *Reader_UT_4.0.3_Setup_NOVUS*, available for download from **NOVUS'** product page. To complete the installation, follow the instructions that will appear on the screen.

4.3 CONNECT THE DEVICE TO THE COMPUTER

Once the USB driver for the **Telik Gardo Reader** and the configuration software has been installed, you can configure the device. Then you should follow the steps below:

1. Connect the **Telik Gardo Reader** to a power supply (for more information about the power supply and voltage ranges, see [TECHNICAL SPECIFICATIONS](#) chapter).
2. Connect the device to mains power. The power indicator light on the device should light up and flash at intervals.
3. After installing the USB driver for the device, connect the USB cable from **Telik Gardo Reader** to the computer's USB interface.
4. Run the **Telik Gardo** software.

The figure below shows the communication and power interfaces of the device:



Figure 7

5 HOW TO USE TELIK GARDO SOFTWARE

5.1 SOFTWARE INITIAL RUN

1. To run **Telik Gardo** software, double-click the following shortcut icon on your computer desktop:



Figure 8

2. After starting the software, open the Windows "Device Manager". Check the **Ports (COM & LPT)** section. In it, find the *Silicon Labs CP210X USB to UARTBridge (COMX)* device.

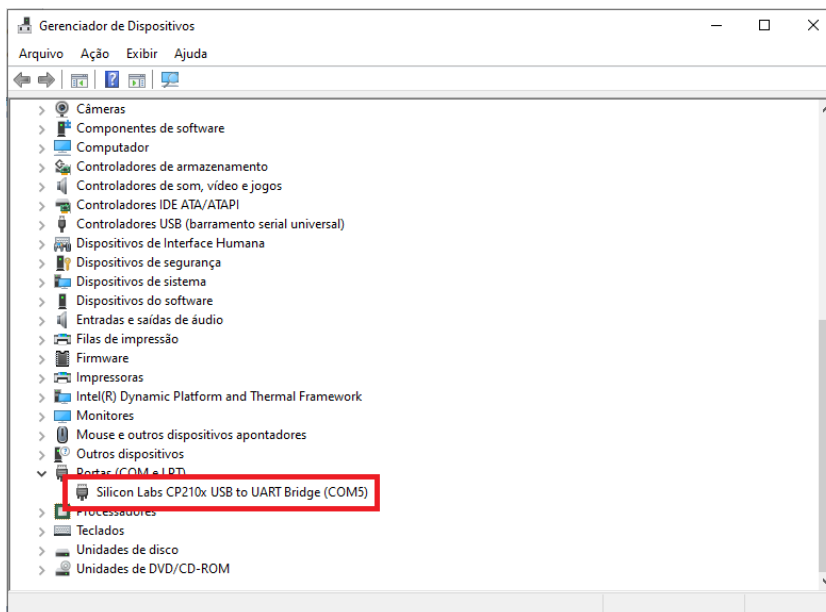

Figure 9

3. Select the USB COMX port and click **Open**:

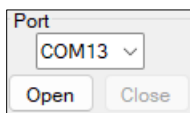

Figure 10

4. The following window will be displayed:

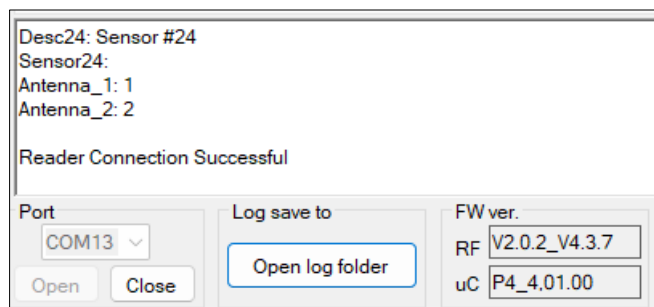

Figure 11

Make sure that the parameter **FW Ver.** displays the version number. The example above shows a situation where **Telik Gardo Reader** is properly connected.

5. Click the **Start** button. The software will display messages regarding the scanning of the sensors connected to the reader:

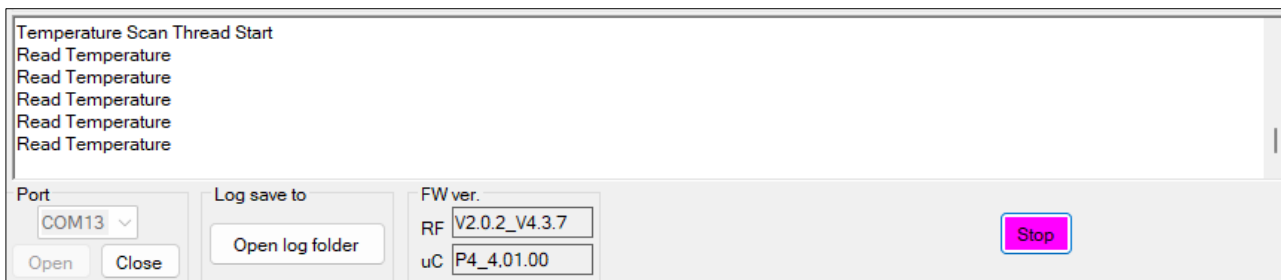

Figure 12

If displayed, the message "Timeout" indicates that communication between the device and the software was unsuccessful. This does not stop the device from working but indicates that it is busy and is in No_Resp mode.

5.2 TELIK GARDO SOFTWARE INTERFACE

Once opened, the **Telik Gardo** software will display the following interface:

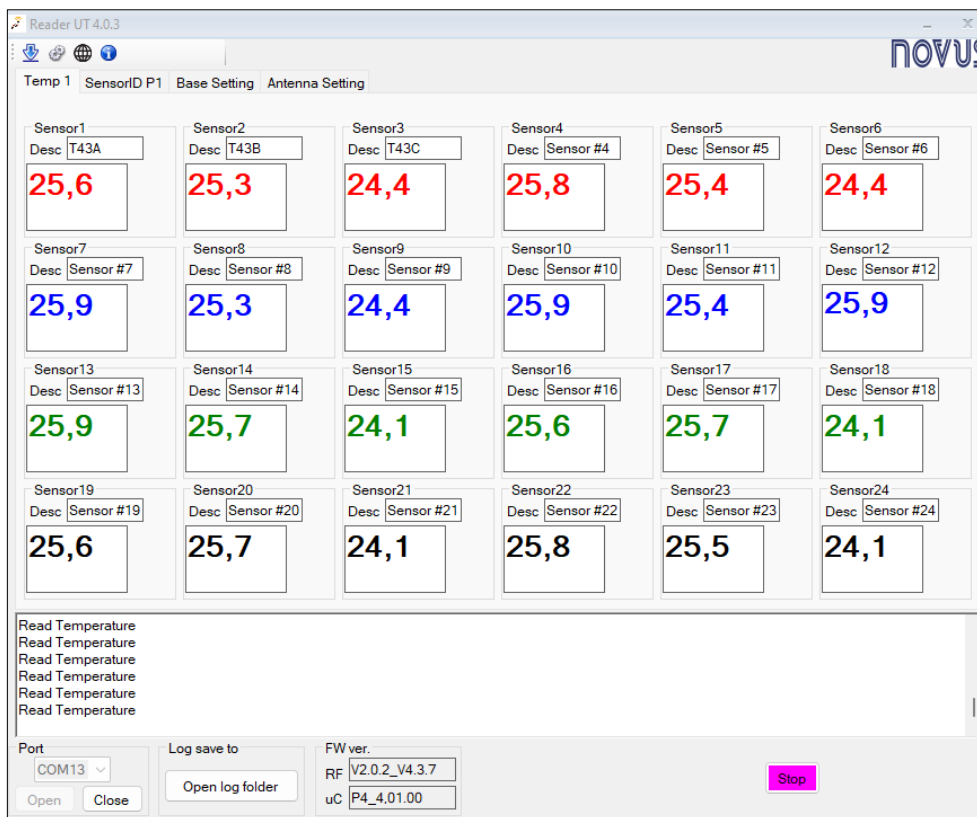

Figure 13

This interface is divided into the following sections:

5.2.1 SOFTWARE VERSION

The software version is displayed at the top of the window:

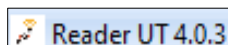

Figure 14

For software updates, check NOVUS website periodically.

5.2.2 PANEL WITH CONFIGURATION FUNCTIONS

These are the tabs with configuration functions:

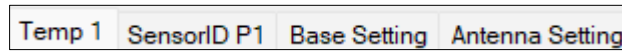

Figure 15

- **Temp 1:** Displays information about the sensor status and the sensor notification panel.
- **SensorID P1:** Allows you to enable or disable sensors and sensor identification settings. For more information, see [HOW TO CONFIGURE THE P1 SENSORID INTERFACE](#) section.
- **Basic Settings:** Allows you to configure the address and put the panel in test mode. For more information, see [HOW TO PERFORM A BASIC CONFIGURATION](#) section.
- **Antenna Settings:** Allows you to enable or disable the antenna. For more information, see [HOW TO CONFIGURE THE ANTENNAS](#) section.

5.2.3 DISPLAYING TEMPERATURE DATA FOR THE SENSOR

This section displays the temperature data from the sensor used:

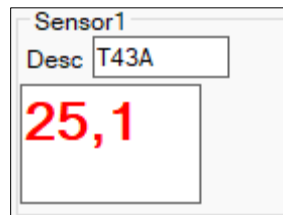

Figure 16

In addition to the temperature value, the software can also display the following messages:

- When the warning "Reading Failed" is displayed: There has been a failure to read the temperature.
- When the warning "Not configured" is displayed: The sensor ID has not been set.
- When the warning "Disabled" is displayed: This sensor has been disabled.
- When "---" is displayed: Software still in boot process. The software has not received any temperature readings.
- When the warning "ANT Disabled" is displayed: The antenna to read the sensor has been disabled.

5.2.4 SELECTION OF THE RELATED USB COMMUNICATION PORT

You can select which USB port to use:

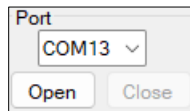

Figure 17

You can find the computer's COM port under "Control Panel" → "Device Manager" → "Silicon Labs CP210x USB to UART Bridge Port".

- **Open/Close** button: Allows you to start/stop the connection with the reader.

For more information about the USB interface, see [USB INTERFACE](#) section.

5.2.5 REAL-TIME DATA COLLECTION FUNCTION

By clicking on the **Open log folder** button, you can view the folder created for saving information about the data collection:

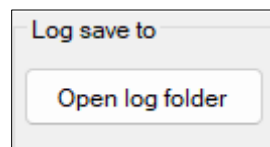

Figure 18

The "T_Log" folder will be created when you first use the software (at reading temperature). By double-clicking **Open log folder** and choosing the "3.0" folder within it, you can find the log file of the reading.

Each reading will generate a document, as shown in the figure below. The file will be named after the reading has been stopped.

 Export_Parameter_2023_6_7_11_4	07/06/2023 11:04	Documento de Texto	2 KB
 log1_R_2023_6_7_11_4	07/06/2023 11:05	Arquivo de Valores Sepa...	19 KB

Figure 19

File description:

- Text file "Export_Parameter_(Time)": Log file for reader parameters at the beginning of the reading.

- CSV file "Log_(Time)": Real-time log file for reading temperatures, antenna signal, etc.

5.2.6 FIRMWARE VERSION

This section displays the firmware version of the device:

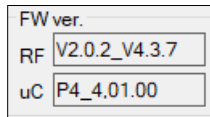

Figure 20

Field description:

- **RF**: Refers to the Radio Module.
- **uC**: Refers to the Control Module.

When installing a new control module firmware, you should test its compatibility with the Telik Gardo software version. This will prevent errors in the device. Check NOVUS website periodically for firmware updates.

5.2.7 START/STOP SENSOR READING

This button is used to start or stop the sensor reading:



Figure 21

5.3 HOW TO CONFIGURE THE P1 SENSORID INTERFACE

This section displays instructions on how to assign an ID for the sensor read by **Telik Gardo Reader**. The sensor settings will be visible when the read function is enabled to request signals from **Telik Gardo Reader**.

To do this, you must click on the **SensorID P1** tab of the configuration software, as shown in the figure below:

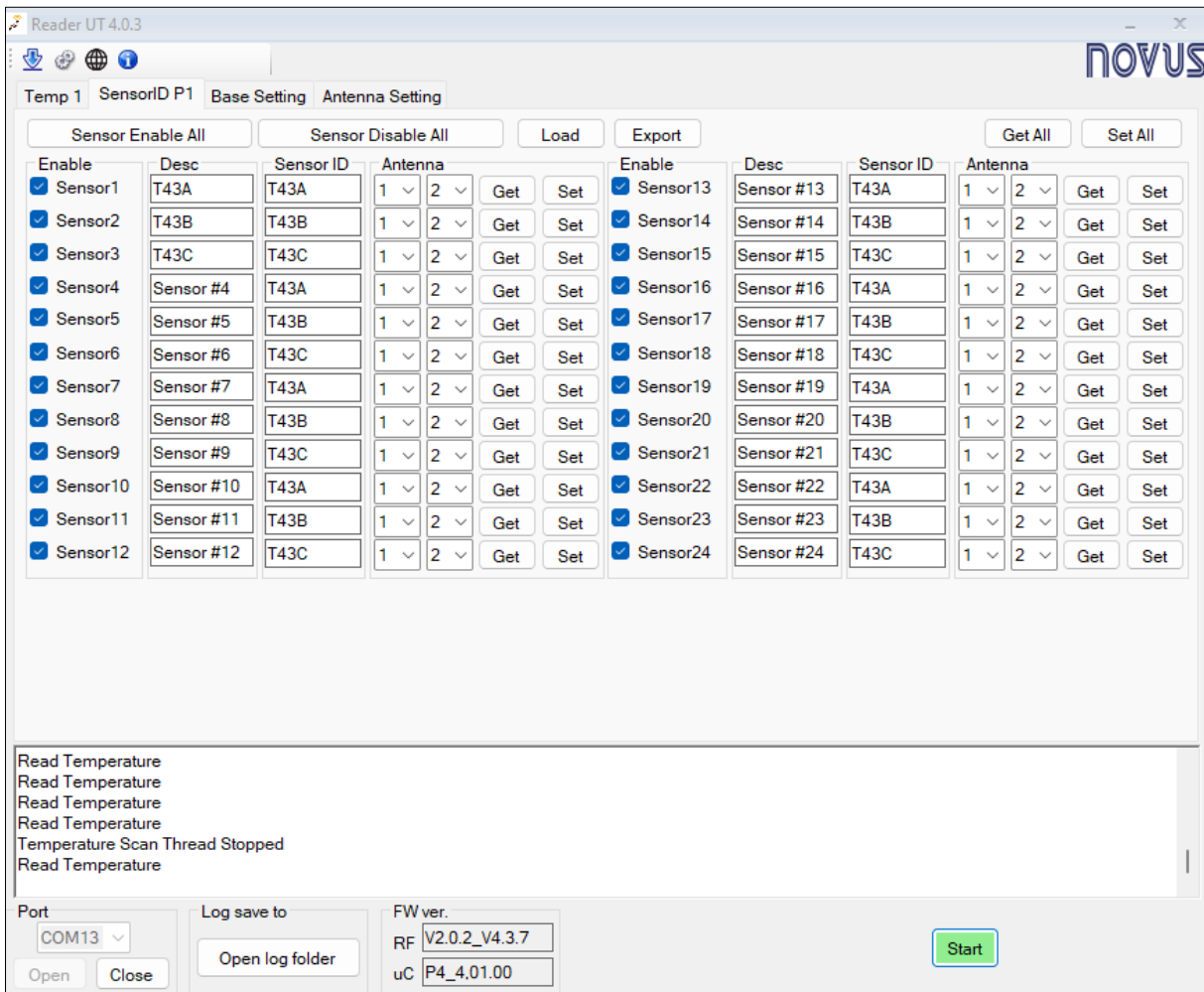

Figure 22

Then you should follow the steps below:

1. Select the sensors to be read by the device:

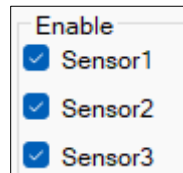

Figure 23

2. Define an ID and a description for the sensor:

Desc	Sensor ID
T43A	T43A
T43CB	T43B
T43C	T43C

Figure 24

Field description:

- **Desc:** Allows you to enter a description for the sensor. You can use letters and numbers (Example: X33A).
- **Sensor ID:** Allows you to enter an ID for the sensor. You can enter numbers and upper-case and lower-case letters.

Advanced Function: After defining the sensor ID, you can double-click on the text in the "Sensor ID" field. This allows you to copy the information from the Sensor ID column to the Desc column.

3. Set the antenna port for the sensor (ANT 1 ~ ANT 4):

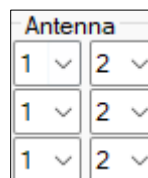

Figure 25

You must configure the antenna according to the field tests previously performed. Each sensor can have a maximum of 2 antennas.

4. Use the **Read** and **Write** buttons to set the parameters. The **Read** button allows you to get the current configuration parameters. The **Write** button allows you to overwrite and update the **Telik Gardo Reader** settings with the defined parameters.
5. You can use the **Read All** and **Write All** buttons (located in the upper right corner of this tab) to get or set all the configuration parameters.
6. You can use the **Enable All Sensors** and **Disable All Sensors** buttons to enable or disable all sensors at once.
7. You can use the **Load** and **Export** buttons to load or export the function list.
8. You can use the **Read All** and **Write All** buttons to collect or configure all sensor information at once.

5.4 HOW TO PERFORM A BASIC CONFIGURATION

This section displays information on how to configure a slave for the Modbus communication protocol (**Telik Gardo Reader** for master device). To do this, you must click on the **Basic Settings** tab, as shown in the figure below:

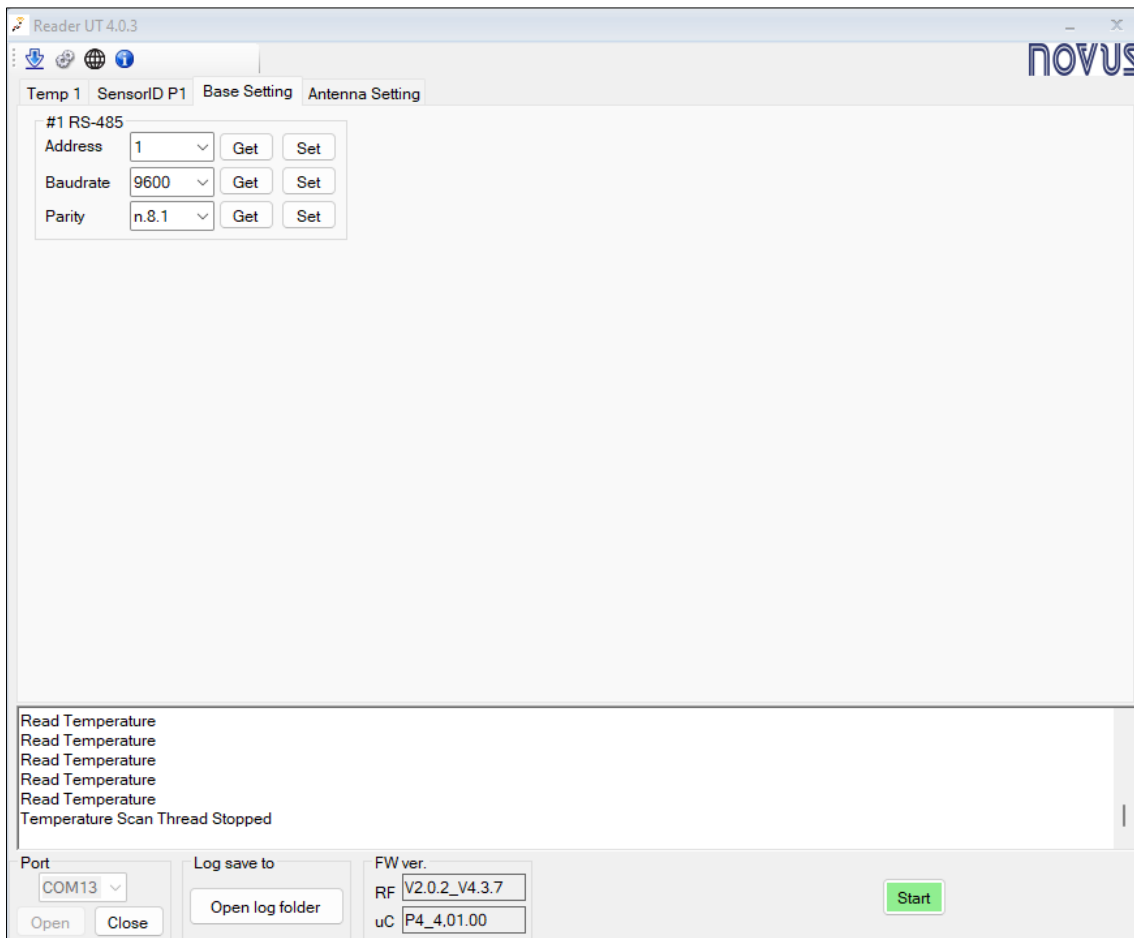

Figure 26

On this screen, you must configure the parameters of the RS485 interface:

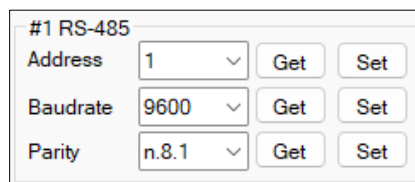

Figure 27

You must choose the desired settings from the options for each parameter. The **Read** button allows you to overwrite the data. The **Write** button allows you to get the current parameters.

Parameter description:

- **Slave address:** Allows you to define the slave address to be used.
- **Baud Rate:** Allows you to define the Baud Rate to be used.
- **Parity:** Allows you to define the parity, data length and Stop Bits.

For more information about the RS485 interface, see [RS485 INTERFACE](#) section.

5.5 HOW TO CONFIGURE THE ANTENNAS

This section presents instructions on how to enable or disable the antenna ports of **Telik Gardo Reader**. To do this, you must click on the **Antenna Settings** tab, as shown in the figure below:

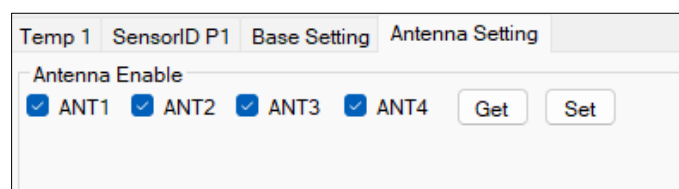

Figure 28

Then you should follow the steps below:

1. Enable the desired antenna (ANT 1 ~ ANT 4):

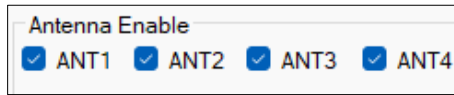

Figure 29 Enabling the antennas

The ANT 1 ~ ANT 4 options do not appear until the COM port is enabled.

2. Use the **Read** and **Write** buttons to get or set all the configuration parameters.

5.6 HOW TO USE THE TOOLBAR

5.6.1 TOOLBAR

This is the toolbar:

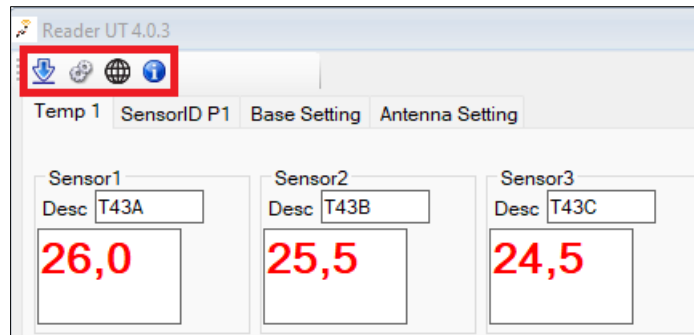







Figure 30

Icon description:

-  : Allows you to download and upgrade the firmware of the module and the base board.
-  : Allows you to open the control panel.
-  : Allows you to change the language settings.
-  : Displays information about the software version.

5.6.2 RF CTRL INTERFACE INSTRUCTIONS

You must click on the  icon to open the RF CTRL interface, as shown in the figure below:

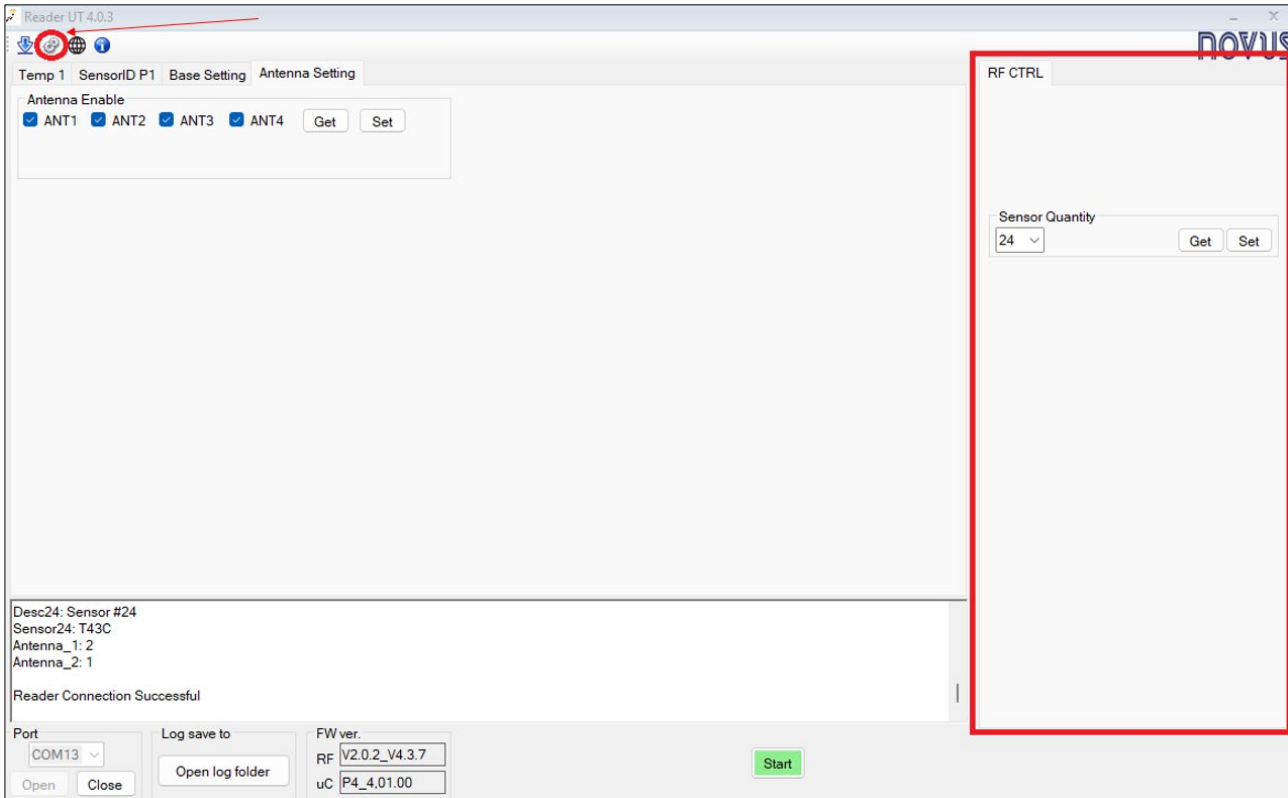



Figure 31

5.6.3 FIRMWARE DOWNLOAD INTERFACE INSTRUCTIONS

You must click the  icon to open the interface for downloading the module or base board firmware, as shown in the figure below:

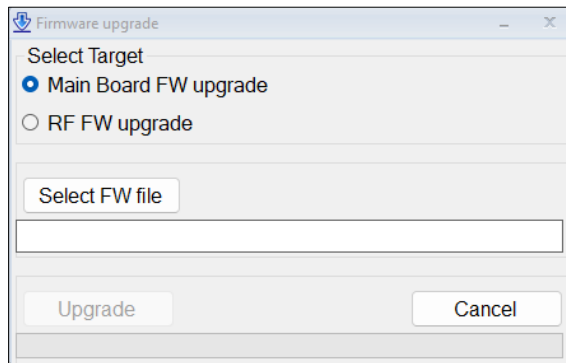

Figure 32

Then you should follow the steps below:

1. Select the firmware to upgrade and click **Select FW File**. This will allow you to choose the destination folder:

 TGModulo_V4.37.bin	24/02/2022 00:07	Arquivo BIN	207 KB
 Reader_FW_P4_v4_00_04.bin	24/02/2022 00:07	Arquivo BIN	52 KB

Figure 33

Files description:

- **RF Firmware:** TGModulo_V4.XX... bin file to update the RF Module firmware.
- **Motherboard firmware:** TGPlacaMae_FW_P8... bin file for updating the motherboard firmware.

2. The update should proceed after choosing the firmware file. The loading bar indicates the progress of the process:

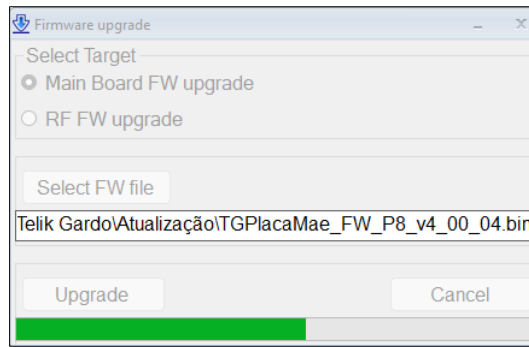

Figure 34

3. After the update has been completed, Windows will display the following pop-up:

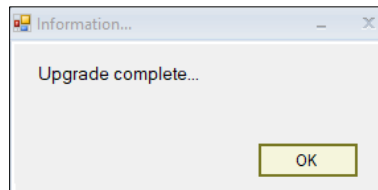

Figure 35



During the upgrade process, do not disconnect the device's power supply or USB connection cables. Otherwise, there may be a failure during the upgrade, as well as irreversible damage. If something happens, contact Technical Support.

6 MODBUS-RTU PROTOCOL

Telik Gardo Reader is compatible with the Modbus-RTU protocol, a data communication protocol used to connect the device to supervisory control and data acquisition systems (SCADA).

6.1 COMMANDS

READ HOLDING REGISTERS – 0x03:

This command can be used to read the value of one or up to a maximum of 125 consecutive registers, according to the **Register Table**.

6.2 REGISTERS TABLE

ADDRESS	DESCRIPTION	UNIT	RANGE
1300	Temperature Sensor #1	0.1 °C	-400 ~ 1500
1301	Temperature Sensor #2	0.1 °C	-400 ~ 1500
1302	Temperature Sensor #3	0.1 °C	-400 ~ 1500
1303	Temperature Sensor #4	0.1 °C	-400 ~ 1500
1304	Temperature Sensor #5	0.1 °C	-400 ~ 1500
1305	Temperature Sensor #6	0.1 °C	-400 ~ 1500
1306	Temperature Sensor #7	0.1 °C	-400 ~ 1500
1307	Temperature Sensor #8	0.1 °C	-400 ~ 1500
1308	Temperature Sensor #9	0.1 °C	-400 ~ 1500
1309	Temperature Sensor #10	0.1 °C	-400 ~ 1500
1310	Temperature Sensor #11	0.1 °C	-400 ~ 1500
1311	Temperature Sensor #12	0.1 °C	-400 ~ 1500
1312	Temperature Sensor #13	0.1 °C	-400 ~ 1500
1313	Temperature Sensor #14	0.1 °C	-400 ~ 1500
1314	Temperature Sensor #15	0.1 °C	-400 ~ 1500
1315	Temperature Sensor #16	0.1 °C	-400 ~ 1500
1316	Temperature Sensor #17	0.1 °C	-400 ~ 1500
1317	Temperature Sensor #18	0.1 °C	-400 ~ 1500
1318	Temperature Sensor #19	0.1 °C	-400 ~ 1500
1319	Temperature Sensor #20	0.1 °C	-400 ~ 1500
1320	Temperature Sensor #21	0.1 °C	-400 ~ 1500
1321	Temperature Sensor #22	0.1 °C	-400 ~ 1500
1322	Temperature Sensor #23	0.1 °C	-400 ~ 1500
1323	Temperature Sensor #24	0.1 °C	-400 ~ 1500
1324	Temperature Sensor #25	0.1 °C	-400 ~ 1500
1325	Temperature Sensor #26	0.1 °C	-400 ~ 1500
1326	Temperature Sensor #27	0.1 °C	-400 ~ 1500
1327	Temperature Sensor #28	0.1 °C	-400 ~ 1500
1328	Temperature Sensor #29	0.1 °C	-400 ~ 1500
1329	Temperature Sensor #30	0.1 °C	-400 ~ 1500
1330	Temperature Sensor #31	0.1 °C	-400 ~ 1500
1331	Temperature Sensor #32	0.1 °C	-400 ~ 1500
1332	Temperature Sensor #33	0.1 °C	-400 ~ 1500
1333	Temperature Sensor #34	0.1 °C	-400 ~ 1500
1334	Temperature Sensor #35	0.1 °C	-400 ~ 1500
1335	Temperature Sensor #36	0.1 °C	-400 ~ 1500

ADDRESS	DESCRIPTION	UNIT	RANGE
1336	Temperature Sensor #37	0.1 °C	-400 ~ 1500
1337	Temperature Sensor #38	0.1 °C	-400 ~ 1500
1338	Temperature Sensor #39	0.1 °C	-400 ~ 1500
1339	Temperature Sensor #40	0.1 °C	-400 ~ 1500
1340	Temperature Sensor #41	0.1 °C	-400 ~ 1500
1341	Temperature Sensor #42	0.1 °C	-400 ~ 1500
1342	Temperature Sensor #43	0.1 °C	-400 ~ 1500
1343	Temperature Sensor #44	0.1 °C	-400 ~ 1500
1344	Temperature Sensor #45	0.1 °C	-400 ~ 1500
1345	Temperature Sensor #46	0.1 °C	-400 ~ 1500
1346	Temperature Sensor #47	0.1 °C	-400 ~ 1500
1347	Temperature Sensor #48	0.1 °C	-400 ~ 1500

Table 3

6.2.1 RELATIVE HUMIDITY INFORMATION (OPTIONAL)

ADDRESS	DESCRIPTION	UNIT	RANGE
1491	Room temperature 1	0.1 °C	-400 ~ 1500
1492	Humidity 1	0.1 %	0 ~ 999
1493	Dew point 1	0.1 °C	-400 ~ 1500
1494	Room temperature 2	0.1 °C	-400 ~ 1500
1495	Humidity 2	0.1 %	0 ~ 999
1496	Dew point 2	0.1 °C	-400 ~ 1500
1497	Room temperature 3	0.1 °C	-400 ~ 1500
1498	Humidity 3	0.1 %	0 ~ 999
1499	Dew point 3	0.1 °C	-400 ~ 1500

Table 4

7 TECHNICAL SPECIFICATIONS

FEATURES	TELIK GARDO READER
Operating temperature	-20 to 70 °C (-4 to 158 °F)
Frequency range	902–907.5 MHz and 915–928 MHz
Antenna ports	4 ports
Range / Receive range	Up to 2 meters, depending on the position of the antenna and sensor.
Dimensions	80 x 45 x 118 mm
Communication interfaces	USB 2.0 Interface RS485 Communication Interface with Modbus-RTU protocol
Power supply	100 ~ 240 V (±10 %)
Software	Telik Gardo Software
Certifications	Anatel (01031-22-11205), FCC, CE

Table 5

FEATURES	TELIK GARDO ANTENNA
Connector	SMA Male
Dimensions	46.5 x 21.1 x 22.2 mm
Installation type	Assemble with magnet or screw.
Operating temperature	-20 to 85 °C (-4 to 185 °F)
Polarization	Circular
Antenna gain	3 dbi
Protection Index	IP54

Table 6

FEATURES	TELIK GARDO SENSOR
Accuracy	± 2 °C (± 3.6 °F)
Dimensions	69 x 27 x 23 mm
Installation type	Screw or clamp
Reading range	2-3 meters
Operating temperature	-20 to 125 °C (-4 to 257 °F)
Measurement range	-20 to 125 °C (-4 to 257 °F)
Protection index	IP30
Maximum monitored line voltage	40 kV

Table 7

7.1 CERTIFICATIONS

ANATEL

This device is homologated by ANATEL, according to the regulated procedures for conformity assessment of telecommunications products, and meets the technical requirements applied.

This equipment is not subject to the protection from harmful interference and may not cause interference with duly authorized systems.

For more information, see ANATEL website: www.anatel.gov.br.

FCC

FCC ID: 2A3F5PQS-RD-01

This equipment has been tested and found to comply with the limits for a Class A digital device, pursuant to Part 15 of the FCC Rules. These limits are designed to provide reasonable protection against harmful interference when the equipment is operated in a commercial environment. This equipment generates, uses, and can radiate radio frequency energy and, if not installed and used in accordance with the instruction manual, may cause harmful interference to radio communications.

Any changes or modifications not expressly approved by the party responsible for compliance could void the user's authority to operate this equipment.

RF Exposure: To meet the FCC RF exposure requirements for mobile and base station transmission, a separation distance of 6.5 cm or more must be maintained between the antenna of this device and people during operation. To ensure compliance, it is not recommended to operate at a closer distance. The antennas used for this transmitter must not coincide or operate with any other antenna or transmitter.

This device complies with part 15 of the FCC Rules. Operation is subject to the following two conditions: (1) This device may not cause harmful interference, and (2) this device must accept any interference received, including interference that may cause undesired operation.

CE Mark

This is a Class A product. In a domestic environment, this product may cause radio interference in which case the user may be required to take adequate measures.

8 WARRANTY

Warranty conditions are available on our website www.NOVUSautomation.com/warranty.