



# **QM-Height High-Precision Digital Height Gauge**

**QMH-600AX**

**QMH-600BX**

**QMH-350AX**

**QMH-350BX**

**QMH-24"AX**

**QMH-24"BX**

**QMH-14"AX**

**QMH-14"BX**

## **User's Manual - Instructions for use -**

Read this User's Manual thoroughly before operating the instrument. After reading, retain it close at hand for future reference.

No. 99MAF600B

Date of publication: December 1, 2018 (1)



---

## ■ Correspondence of product names and model numbers

Product name	Model number
QM-Height	QMH-600AX
High-Precision Digital Height Gauge	QMH-600BX
	QMH-350AX
	QMH-350BX
	QMH-24"AX
	QMH-24"BX
	QMH-14"AX
	QMH-14"BX

## ■ Notice regarding this guide





- Mitutoyo Corporation assumes no responsibilities for any damage to the instrument, caused by its use not conforming to the procedure described in this User's Manual.
- Upon loan or transfer of this instrument, be sure to attach this User's Manual to the instrument.
- In the event of loss or damage to this manual, immediately contact a Mitutoyo sales office or your dealer.
- Before operation of the instrument, thoroughly read this manual to comprehend its contents.
- Particularly, for full understanding of information, carefully read "Safety Precautions" and "Precautions for Use" at the outset of this manual before using the instrument.
- The contents in this manual are based on the information current as of December, 2018.
- No part or whole of this manual may be transmitted or reproduced by any means without prior written permission of Mitutoyo Corporation.
- Some screen displays in this manual may be highlighted, simplified or partially omitted for convenience of explanation. In addition, some of them may differ from actual ones to the extent that no user will misunderstand the functions and operations.
- The corporation, organization and product names that appear in this manual are their trademarks or registered trademarks.

© 2018 Mitutoyo Corporation. All rights reserved.



# CONVENTIONS USED IN MANUALS

Conventions used in Mitutoyo's User's Manual are roughly divided into three types (safety reminders, prohibited and mandatory actions, and referential information and locations). Moreover, these safety symbols include general warnings and specific warnings. Specific warning symbols are provided with concrete pictograms inside of them.

## ■ Safety reminder conventions and wording warning against potential hazards

General	 <b>DANGER</b>	Indicates an immediately hazardous situation which, if not avoided, will result in serious injury or death.
	 <b>WARNING</b>	Indicates a potentially hazardous situation which, if not avoided, could result in serious injury or death.
	 <b>CAUTION</b>	Indicates a potentially hazardous situation which, if not avoided, may result in minor injury.
	 <b>NOTICE</b>	Indicates a potentially hazardous situation which, if not avoided, may result in property damage.
Specific		Alerts the user to a specific hazardous situation that means "Caution, risk of electric shock".

## ■ Conventions and wording indicating prohibited and mandatory actions

General		Indicates concrete information about prohibited actions.
		Indicates concrete information about mandatory actions.
Specific		Indicates that grounding needs to be implemented.

## ■ Conventions and wording indicating referential information or referential locations

**Tips** Indicates referential information such as that for when the operating methods and procedures which are printed in these sentences are to be applied to specific conditions.



Indicates referential locations if there is information that should be referred to in this guide or an extraneous manual.

E.g.: For details,  "2.1 Measuring the Height" (page 17)

---

# Safety Precautions

Read these Safety Precautions thoroughly before operating the system to use it properly.

These safety precautions include such information as to prevent an injury to the operator and other persons or damage to property. Be sure to observe the precautions.

## **WARNING**

- Do not disassemble or modify this product. Doing so can result in fire or electric shock.
- Do not place the product on an unstable surface. It may fall or topple over, causing an injury.
- Do not place containers with water, such as flower pots, near this product. If water gets into the device, a fire or electric shock may occur. If water does get into the device, turn off the power, and contact us. Continuing to use the device may result in a fire or electric shock.
- Do not use the device in areas where volatile gases may be released. Doing so can result in a fire.

## **CAUTION**

- Do not apply an external voltage to the product with a device such as an electric engraver. Doing so may lead to damage or malfunction.
- If the device will not be used for an extended period of time, remove the batteries. Battery leakage can damage the device.
- Only use LR6 (AA alkaline) or Ni-MH (nickel metal hydride) batteries. Handle the batteries according to their instructions.
- Do not charge or disassemble the accompanying batteries. They may short circuit.

---

# Precautions for Use

## ■ Product applications and handling

- This product is a measuring instrument.

Do not use it for any purposes other than measuring.

- This product is precision equipment.

It must be carefully handled. Be careful not to apply excessive shock or force to any of the parts during operation.

## ■ Installation environment

Only use this product in the following environments.

- Areas free of dirt and dust
- Areas free of vibrations
- Areas with an ambient temperature between 0 °C and 40 °C (For precision measurements, the temperature should be consistently around 20 °C.)
- Areas with low humidity
- On a surface plate

Avoid using the product in the following environments.

- In locations where it may directly exposed to cutting fluids, water, etc.
- In locations where it may be exposed directly to sunlight or hot or cold wind
- In locations near machines that generate electromagnetic noise, such as welders or electrical discharge machines

## ■ Maintenance

- Clean the main unit, base, or probe by wiping it with a lint-free cloth or paper towel dampened with a neutral detergent. Do not use an organic solvent such as a thinner.
- In order to prevent dirt and dust accumulation, we recommend covering the main unit with the included product cover.

## ■ Power supply

- Turn off the power after use.
- Do not connect the AC adapter (optional accessory) to a high-current power supply used by machine tools or large CNC measuring instrument.
- If the power to the product is cut off by removing the batteries or the AC adapter (optional accessory) cable, the following contents will be erased:
  - Incremental measurement (INC) reference
    - ☰ "■ INC reference setup" (page 13)
  - Reference for calculating the difference between 2 measurements
    - ☰ "3.1.2 Continuously Measuring the Distance from One Specific Point to Multiple Other Points" (page 33)
  - Measurements stored in the memory
    - ☰ "3.1.3 Calculating the Difference Between Values Stored in the Memory" (page 35)

---

## Electromagnetic Compatibility (EMC)

This product complies with the EU EMC Directive. Note that, in environments where electromagnetic interference exceeds the EMC requirements defined in this directive, appropriate countermeasures are required to ensure product performance.

## Export Control Compliance

This product falls into the Catch-All-Controlled Goods and/or Catch-All-Controlled Technologies (including Programs) under Category 16 of Appended Table 1 of the Export Trade Control Order or under Category 16 of the Appended Table of Foreign Exchange Control Order, based on the Foreign Exchange and Foreign Trade Act of Japan.

If you intend re-export of the product from a country other than Japan, re-sale of the product in a country other than Japan, or re-provision of the technology (including program), you are obligated to observe the regulations of your country.

Also, if an option is added or modified to add a function to this product, this product may fall under the category of List-Control Goods and/or List-Control Technology (including Programs) under Category 1 - 15 of Appended Table 1 of the Export Trade Control Order or under Category 1 - 15 of the Appended Table of Foreign Exchange Control Order, based on Foreign Exchange and Foreign Trade Act of Japan. In that case, if you intend re-export of the product from a country other than Japan, re-sale of the product in a country other than Japan, or re-provision of the technology (including program), you are obligated to observe the regulations of your country. Please contact Mitutoyo in advance.

## Notes on Export to EU Member Countries

When you intend export of this product to any of the EU member countries, you may be required to provide User's Manual(s) in English and EU Declaration of Conformity in English (under certain circumstances, User's Manual(s) in the destination country's official language and EU Declaration of Conformity in the destination country's official language). For detailed information, please contact Mitutoyo in advance.

## Disposal of Products outside the European Union and Other European Countries

Please follow the official instruction in each community and country.

## Disposal of Old Electrical & Electronic Equipment (Applicable in the European Union and Other European Countries with Separate Collection Systems)



This symbol on the product or on its packaging is based on the WEEE Directive (Directive on Waste Electrical and Electronic Equipment), which is a regulation in EU member countries, and indicates that this product shall not be treated as household waste.



To reduce environmental impact and minimize the volume of landfill, please cooperate in reuse and recycling.

For information on how to dispose of the product, please contact your dealer or the nearest Mitutoyo sales office.

# Disposal of Waste Batteries and Accumulators (Applicable in the European Union and Other European Countries with Separate Collection Systems)



Batteries and accumulators containing heavy metals such as mercury, lead, and cadmium may contaminate the environment if improperly discarded. When incinerated, certain chemicals are released into the air or concentrated in the ash residue from the combustion process. These may lead to health risks to humans and animals, and also damage the environment in general.

In compliance with legal requirements, the symbol of a 'crossed-out wheeled bin' is either applied on the battery or on its packaging. This symbol indicates that disposal of the batteries as household wastes is strictly prohibited. Instead, the batteries must be disposed according to separate collection and recycling rules. Additional marking identifies that heavy metal content (i.e. Cd =cadmium, Hg = mercury, Pb = lead) contained within the battery is over prescribed levels. End users are obliged by law to comply with the discarding procedure for waste batteries. At Mitutoyo facilities, or at its appointed distributors, receptacles will be provided to accept the disposal of previously supplied batteries at no charge.

## China RoHS Compliance Information

This product meets China RoHS requirements. See the table below.

产品中有害物质的名称及含量

部件名称	有害物质					
	铅 (Pb)	汞 (Hg)	镉 (Cd)	六价铬 (Cr(VI))	多溴联苯 (PBB)	多溴二苯醚 (PBDE)
本体	×	○	○	○	○	○
配件	○	○	○	○	○	○

本表格依据 SJ/T 11364 的规定编制。

○: 表示该有害物质在该部件所有均质材料中的含量均在 GB/T 26572 规定的限量要求以下。

×: 表示该有害物质至少在该部件的某一均质材料中的含量超出 GB/T 26572 规定的限量要求。



环保使用期限标识, 是根据电器电子产品有害物质限制使用管理办法以及, 电子电气产品有害物质限制使用标识要求(SJ/T11364-2014), 制定的适用于中国境内销售电子电气产品的标识。

电子电气产品只要按照安全及使用说明内容, 正常使用情况下, 从生产月期算起, 在此期限内, 产品中含有的有毒有害物质不致发生外泄或突变, 不致对环境造成严重污染或对其人身、财产造成严重损害。

产品正常使用后, 要废弃在环保使用年限内或者刚到年限的产品时, 请根据国家标准采取适当的方法进行处置。

另外, 此期限不同于质量/ 功能的保证期限。

---

## Warranty

In the event that this product should prove defective in workmanship or material, within one year from the date of original purchase for use, it will be repaired or replaced, at Mitutoyo's option, free of charge upon its prepaid return to Mitutoyo, without prejudice to the provisions of the Mitutoyo Software End User License Agreement.

If this product fails or is damaged for any of the following reasons, it will be subject to a repair charge, even if it is still under warranty.

- Failure or damage owing to fair wear and tear
- Failure or damage owing to inappropriate handling, maintenance or repair, or to unauthorized modification
- Failure or damage owing to transport, dropping, or relocation of the instrument after purchase
- Failure or damage owing to fire, salt, gas, abnormal voltage, lightning surge, or natural disaster
- Failure or damage owing to use in combination with hardware or software other than those designated or permitted by Mitutoyo
- Failure or damage owing to use in ultra-hazardous activities

This warranty is effective only where the instrument is properly installed and operated in conformance with the instructions in this manual within the original country of the installation.

EXCEPT AS SPECIFIED IN THIS WARRANTY, ALL EXPRESS OR IMPLIED CONDITIONS, REPRESENTATIONS, AND WARRANTIES OF ANY NATURE WHATSOEVER INCLUDING, WITHOUT LIMITATION, ANY IMPLIED WARRANTY OF MERCHANTABILITY, FITNESS FOR A PARTICULAR PURPOSE, NONINFRINGEMENT OR WARRANTY ARISING FROM A COURSE OF DEALING, USAGE, OR TRADE PRACTICE, ARE HEREBY EXCLUDED TO THE MAXIMUM EXTENT ALLOWED BY APPLICABLE LAW.

You assume all responsibility for all results arising out of its selection of this product to achieve its intended results.

## Disclaimer

IN NO EVENT WILL MITUTOYO, ITS AFFILIATED AND RELATED COMPANIES AND SUPPLIERS BE LIABLE FOR ANY LOST REVENUE, PROFIT, OR DATA, OR FOR SPECIAL, DIRECT, INDIRECT, CONSEQUENTIAL, INCIDENTAL, OR PUNITIVE DAMAGES HOWEVER CAUSED AND REGARDLESS OF THE THEORY OF LIABILITY ARISING OUT OF THE USE OF OR INABILITY TO USE THIS PRODUCT EVEN IF MITUTOYO OR ITS AFFILIATED AND RELATED COMPANIES AND/OR SUPPLIERS HAVE BEEN ADVISED OF THE POSSIBILITY OF SUCH DAMAGES.

If, notwithstanding the foregoing, Mitutoyo is found to be liable to you for any damage or loss which arises out of or is in any way connected with use of this product by you, in no event shall Mitutoyo's and/or its affiliated and related companies' and suppliers' liability to you, whether in contract, tort (including negligence), or otherwise, exceed the price paid by you for the product only.

The foregoing limitations shall apply even if the above-stated warranty fails in its essential purpose. BECAUSE SOME COUNTRIES, STATES OR JURISDICTIONS DO NOT ALLOW THE EXCLUSION OR THE LIMITATION OF LIABILITY FOR CONSEQUENTIAL OR INCIDENTAL DAMAGES, IN SUCH COUNTRIES, STATES OR JURISDICTIONS, MITUTOYO'S LIABILITY SHALL BE LIMITED TO THE EXTENT PERMITTED BY LAW.

---

# About This Document

## ■ Positioning of this document in document map

This document explains how to use the product and provides troubleshooting information. In addition to this document, a setup guide and a quick reference chart are available.

### ● Operation

User's Manual (This Document)

### ● Setup

Setup Manual

### ● Quick reference chart

Quick Reference Manual

## ■ Intended readers and purpose of this document

### ● Intended readers

This document is intended for beginners of the High-Precision Digital Height Gauge. The readers are assumed to have been familiar with basic operations of a PC and Windows. They are also assumed to be able to understand individual instructions by reading screen displays.

### ● Purpose

To use this product safely and correctly, read this document thoroughly. After reading, keep it in a safe place close to the product.

This document is aimed at understanding how to use the High-Precision Digital Height Gauge to perform basic measurements and specific usage applications.

---

# Contents

<b>CONVENTIONS USED IN MANUALS</b> .....	<b>i</b>
<b>Safety Precautions</b> .....	<b>ii</b>
<b>Precautions for Use</b> .....	<b>iii</b>
<b>Electromagnetic Compatibility (EMC)</b> .....	<b>iv</b>
<b>Export Control Compliance</b> .....	<b>iv</b>
<b>Notes on Export to EU Member Countries</b> .....	<b>iv</b>
<b>Disposal of Products outside the European Union and Other European Countries...</b>	<b>iv</b>
<b>Disposal of Old Electrical &amp; Electronic Equipment (Applicable in the European Union and Other European Countries with Separate Collection Systems)</b> .....	<b>iv</b>
<b>Disposal of Waste Batteries and Accumulators (Applicable in the European Union and Other European Countries with Separate Collection Systems)</b> .....	<b>v</b>
<b>China RoHS Compliance Information</b> .....	<b>v</b>
<b>Warranty</b> .....	<b>vi</b>
<b>Disclaimer</b> .....	<b>vi</b>
<b>About This Document</b> .....	<b>vii</b>
<b>Contents</b> .....	<b>viii</b>
<b>1 Before Using This Product</b> .....	<b>1</b>
1.1 Product Capabilities .....	1
1.2 Part Names and Functions .....	2
1.2.1 Main Unit .....	2
1.2.2 Display Unit .....	4
1.3 Basic Operations .....	7
1.3.1 Turning On the Power .....	7
1.3.2 Moving the Probe .....	7
1.3.3 Moving the Main Unit .....	8
1.4 Preparing Measurements .....	10
1.4.1 Reference Setup .....	10
1.4.2 Ball Diameter Setup .....	14

---

<b>2</b>	<b>Basic Measuring Methods</b>	<b>17</b>
2.1	Measuring the Height	17
2.2	Measuring the Width	19
2.3	Measuring the Inner Diameter	21
2.4	Measuring the Outer Diameter	25
2.5	Measuring the Plane Displacement (Plane Scanning Measurement)	29
<b>3</b>	<b>Specific Usage Applications</b>	<b>31</b>
3.1	Calculating the Difference Between 2 Measurements	31
3.1.1	Determining the Difference Between the Most Recently Measured Value	32
3.1.2	Continuously Measuring the Distance from One Specific Point to Multiple Other Points	33
3.1.3	Calculating the Difference Between Values Stored in the Memory	35
3.2	Judging the Tolerance	38
3.2.1	Setting the Upper and Lower Limits	38
3.2.2	Enabling/Disabling the Judgment Function	39
3.3	Simplifying Measurement Procedures	40
3.3.1	Registering a Measurement Procedure	40
3.3.2	Measuring Using a Registered Measurement Procedure	42
3.4	Setting the Terminating Method for Scanning Measurements	43
3.5	Holding the Displayed Measurement Results	44
3.6	Setting the Resolution for Measurements	44
3.7	Setting the Time Until the Power Turns Off (Auto-Off)	45
3.8	Setting the LED Lighting Time	46
3.9	Outputting Measurement Results to an External Device	47
3.9.1	Outputting to a Mini Printer (Optional Accessory)	47
3.9.2	Outputting to a PC (Windows Only)	48
<b>4</b>	<b>Troubleshooting</b>	<b>51</b>
4.1	If the Following Problem Occurs	51
4.2	If Error Messages Are Displayed	53
<b>5</b>	<b>Maintenance</b>	<b>55</b>

---

<b>6</b>	<b>Specifications</b>	<b>57</b>
6.1	Basic Specifications	57
6.2	Digimatic Data Output Specification	59
6.2.1	Data Format	59
6.2.2	Connector Specification	60
6.2.3	Timing Chart	60
6.3	USB Data Output Specification	61
6.3.1	Communication Specification	61
6.3.2	Data Format	61
6.3.3	Connector Specification	61
6.3.4	Data Format Examples	61
6.4	Accessories	62
6.5	Optional Accessories	63
	<b>SERVICE NETWORK</b>	<b>App-1</b>

# 1 Before Using This Product

This chapter explains the product's characteristics, part names and functions, basic operations, and the settings that must be configured prior to measurement.

## 1.1 Product Capabilities

This product is a measuring instrument that makes measurements by vertically moving a part called a probe into contact with a specific point, and calculating the height of that point. Because the measurements are obtained from the probe's position, this product can measure the inner diameter of holes and the outer diameter of cylinders as well.

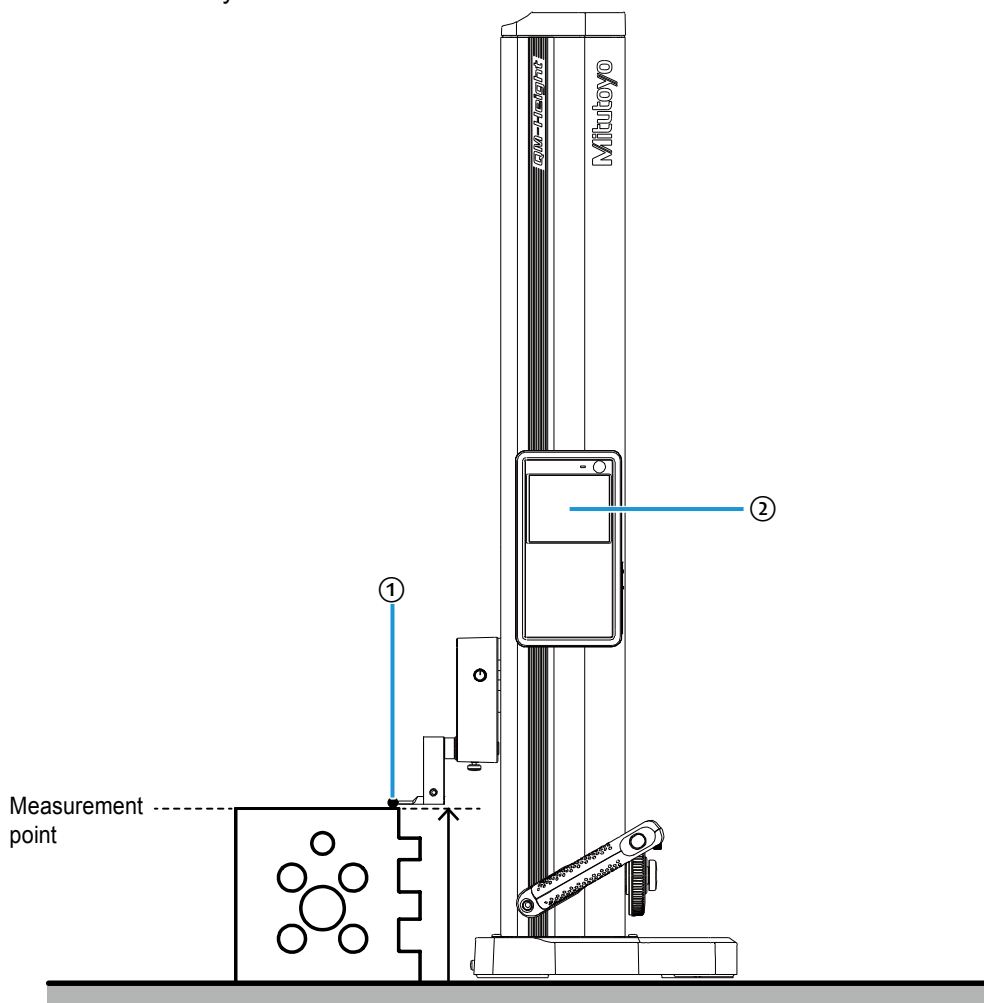

Bring the probe into contact with the point you want to measure (①), and read the displayed measurement (②).

# 1.2 Part Names and Functions

## 1.2.1 Main Unit

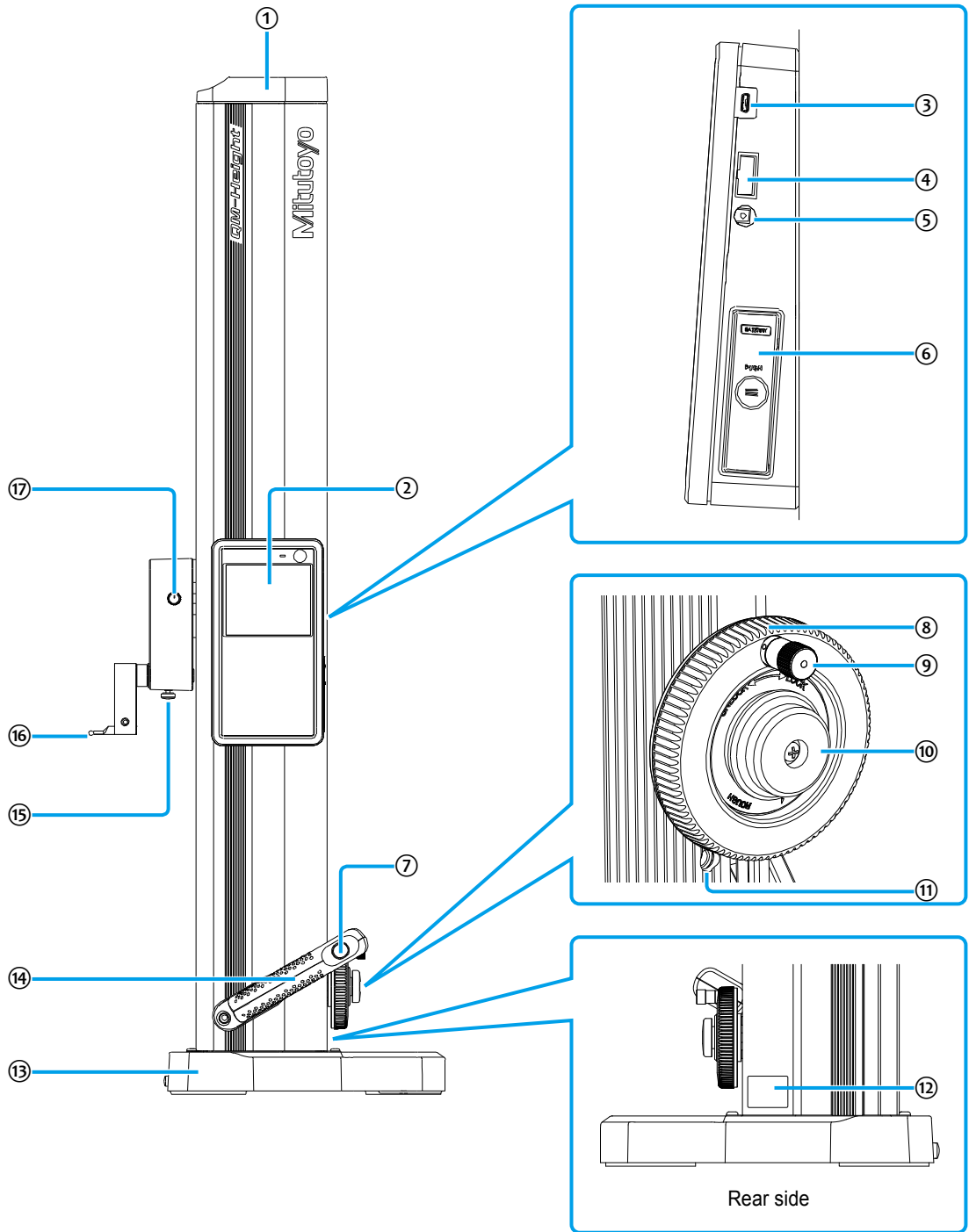

## 1 Before Using This Product

①	Head cover	⑩	Clamp screw Fixes the rotational movement of the probe up/down wheel.
②	Display unit Displays measurements and any messages.	⑪	Float amount adjustment screw (QMH-600BX/QMH-350BX/QMH-24"BX/QMH-14"BX only) Adjusts the amount of airflow used in the air-float function. Turning the screw right increases airflow, and turning it left reduces airflow.
③	Micro USB connector (AB receptacle) <sup>*1</sup> This port is for connecting your PC with a micro USB cable.	⑫	Label Contains the code number of this product.
④	Digimatic output connector <sup>*1</sup> This port is for connecting the optional Digimatic mini-processor.	⑬	Base Contact surface used when installing the main unit on the surface plate. Grip the base when moving the main unit along the surface plate.
⑤	DC jack <sup>*1</sup> This jack is for connecting the optional AC adapter.	⑭	Carrier grip Hold the carrier grip when moving the main unit along the surface plate.
⑥	Battery case A case for inserting the batteries.	⑮	Probe clamp knob Clamps the probe so that it does not come out.
⑦	Air-float switch (QMH-600BX/QMH-350BX/QMH-24"BX/QMH-14"BX only) This switch uses the air-float function to make the main unit float.  <div style="border: 1px solid black; padding: 5px; width: fit-content;"><b>NOTICE</b></div> Measuring with the air-float function active can cause measurement errors	⑯	Probe Used for obtaining measurements. Touch the ball on the tip of the probe to the workpiece to obtain the measurements.
⑧	Probe up/down wheel The probe moves up and down as the wheel is turned left and right.	⑰	Clamp knob Fixes the movement of the probe.
⑨	Probe fine adjustment knob Pulling the knob and turning it moves the probe slowly.		



<sup>\*1</sup> During use, we recommend securing the cable with the included cable clamp.

## 1.2.2 Display Unit

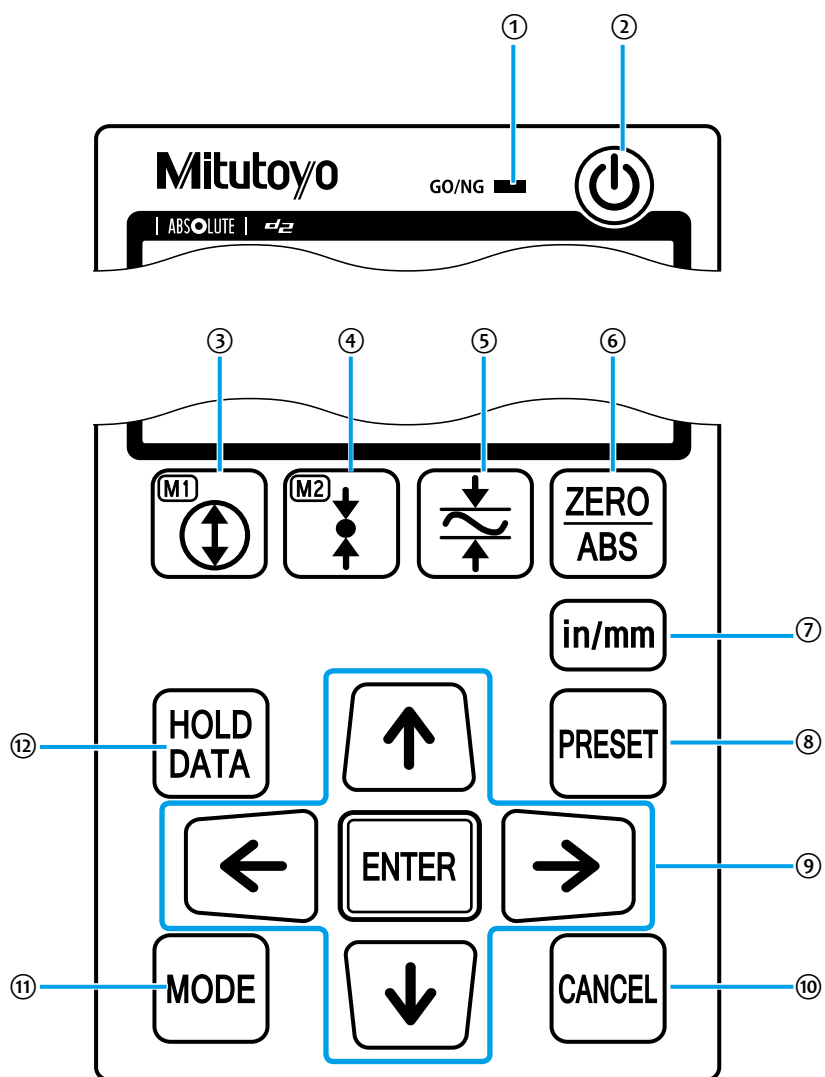
### ■ Operation panel



## 1 Before Using This Product

<p>① Shows the result of the tolerance judgment.</p> <p><b>Tips</b> For details, see "3.2 Judging the Tolerance" (page 38)</p>	<p>⑦ Changes the setting for units between inches and millimeters (only on models that support inches).</p>
<p>② Turns the power on or off.</p>	<p>⑧ Sets a value for the reference.</p>
<p>③ Measures the inner diameter.</p> <p><b>Tips</b> For details, see "2.3 Measuring the Inner Diameter" (page 21)</p>	<p>⑨ Changes numbers and settings. Press  to confirm an operation.</p> <p><b>Tips</b></p> <ul style="list-style-type: none"> <li>• Press and hold  to reverse the counting direction: Moving the probe upwards decreases the value, and moving the probe downwards increases the value. Press and hold the button again to return to normal.</li> <li>• If you reversed the counting direction, follow the procedure in "1.4.1 Reference Setup" (page 10) to reset the reference.</li> </ul>
<p>④ Measures the outer diameter.</p> <p><b>Tips</b> For details, see "2.4 Measuring the Outer Diameter" (page 25)</p>	<p>⑩ Cancels an operation.</p>
<p>⑤ Measures the maximum, minimum, and displacement values (maximum – minimum = displacement) of a horizontal plane.</p> <p><b>Tips</b> For details, see "2.5 Measuring the Plane Displacement (Plane Scanning Measurement)" (page 29)</p>	<p>⑪ Used to change settings for a specific application, such as changing the measurement resolution.</p> <p><b>Tips</b> For details, see "3 Specific Usage Applications" (page 31)</p>
<p>⑥ Switches the reference setting between absolute measurement (ABS) and incremental measurement (INC).</p>	<p>⑫ Holds a measurement in the display and outputs the measurement results to external devices.</p> <p><b>Tips</b> For details, see "3.5 Holding the Displayed Measurement Results" (page 44) and "3.9 Outputting Measurement Results to an External Device" (page 47)</p>

■ LCD screen

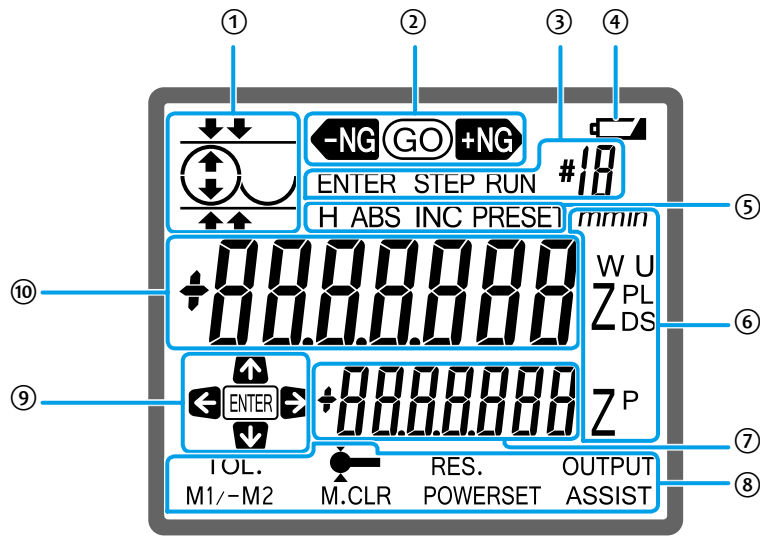

<p>① Displays an icon which represents an operation.</p>	<p>⑥ The meanings of the following letters, which are displayed during measuring, are explained below.</p> <ul style="list-style-type: none"> <li>• [ZP] The difference between 2 measurements</li> <li>• [U]/[L] Upper/Lower tolerances</li> <li>• [ZD] Diameter</li> <li>• [ZL]/[ZS]/[W] Maximum/Minimum/Displacement</li> <li>• [mm] Millimeters (unit)</li> <li>• [in] Inches (unit)</li> </ul>
<p>② Shows the result of the tolerance judgment.</p> <p><b>Tips</b> For details, see "3.2 Judging the Tolerance" (page 38)</p>	
<p>③ Displayed when registering measurement steps or executing steps that have been registered.</p> <p><b>Tips</b> For details, see "3.3 Simplifying Measurement Procedures" (page 40)</p>	
<p>④ Displayed when the battery is empty.</p>	<p>⑦ Displays the difference with the previous measurement.</p> <p><b>Tips</b> For details, see "3.1 Calculating the Difference Between 2 Measurements" (page 31)</p>
<p>⑤ Displayed during the following operations.</p> <ul style="list-style-type: none"> <li>• [H] When a measurement is being held in the display.</li> <li>• [ABS]/[INC] When the reference setting has been switched between absolute measurement (ABS) and incremental measurement (INC).</li> <li>• [PRESET] When setting a value for the ABS reference.</li> </ul>	<p>⑧ Displays the available settings when <b>MODE</b> is pressed.</p> <p><b>Tips</b> For details, see "3 Specific Usage Applications" (page 31)</p>
	<p>⑨ Shows which keys can be used during an operation.</p>
	<p>⑩ Displays the measurement.</p> <p><b>Tips</b> For details, see "2 Basic Measuring Methods" (page 17)</p>

# 1.3 Basic Operations

This section explains how to turn on the power, as well as how to move the probe and the main unit.

## 1.3.1 Turning On the Power

Press  on the upper right of the LCD screen to turn on the power.



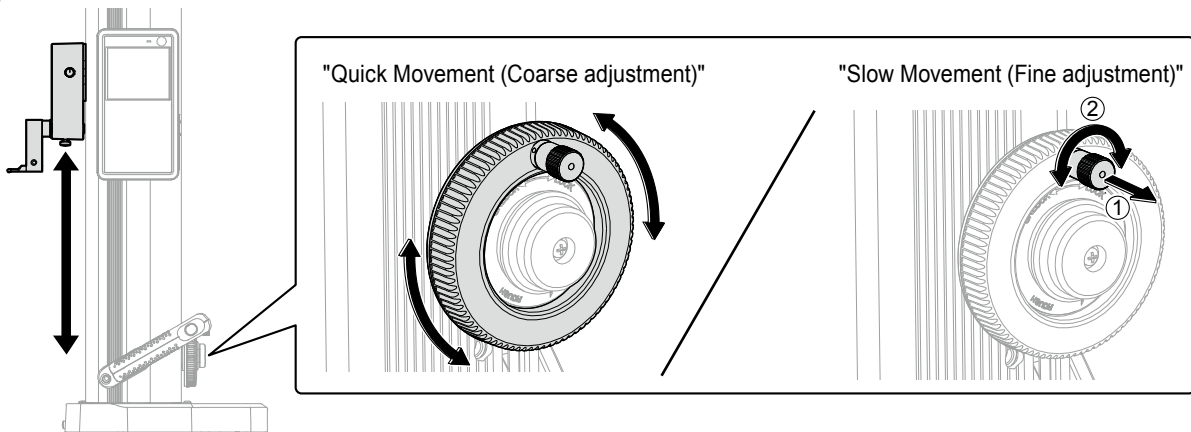

## 1.3.2 Moving the Probe

Turn the probe up/down wheel right and left to move the probe up and down, respectively. When bringing the ball at the tip of the probe into contact with the workpiece or surface plate, be sure to move the probe slowly. The probe can be moved slowly by pulling out and turning the probe fine adjustment knob.



When the ball contacts the measurement surface with a consistent force, a beep sound is made, and the height position is measured.

### NOTICE

- In order to prevent a reduction in the product's performance, do not move the probe by grabbing it.
- If the display value remains held even when you move the probe vertically, press . If this does not release the hold, follow the steps in  ■ "When the displayed value is held, and the workpiece cannot be measured" (page 52) to release the hold.

### 1.3.3 Moving the Main Unit

When moving the main unit on the surface plate, grab the base with your right hand and the carrier grip with your left hand.

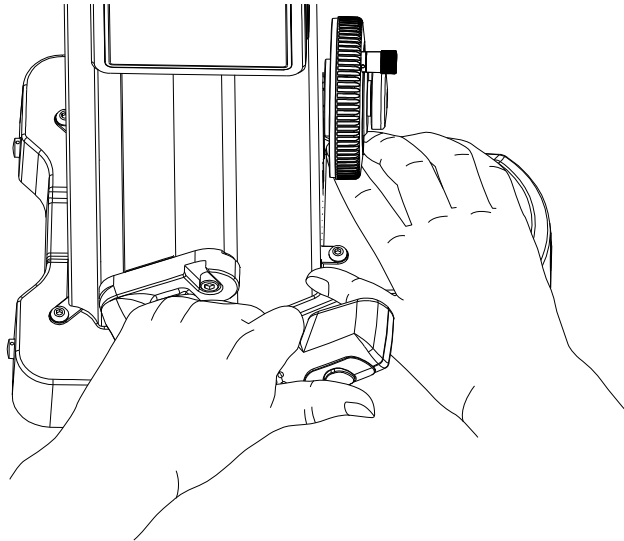

For QMH-600BX/QMH-350BX/QMH-24"BX/QMH-14"BX, pressing the air-float switch on the tip of the carrier grip causes air to make the main unit float, allowing you to move it smoothly above the surface plate.

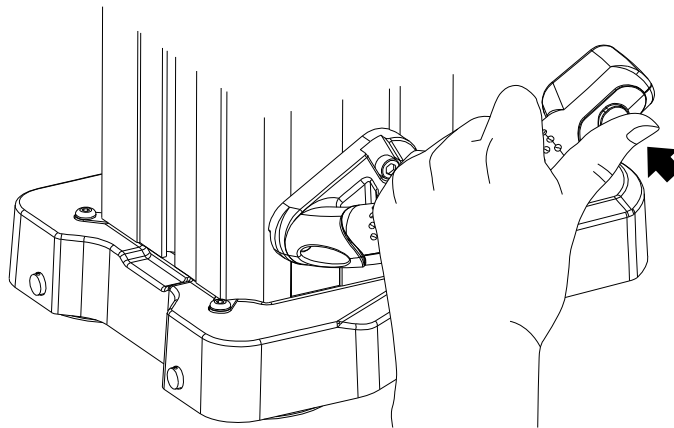

**NOTICE**

Do not move the product by grabbing parts other than the base or carrier grip. Doing so can negatively affect measurement accuracy and the product itself.

**NOTICE**

If using the air-float function:

- Measuring with the air-float function active can cause measurement errors.
- Clean the surface plate in advance.
- Use a surface plate of Class JIS1 or higher. If the surface plate is scratched or uneven, the specified performance may not be achieved.
- Use a rigid surface plate. If the surface plate warps under the weight of the product, the product may not float.

## 1 Before Using This Product

---

### NOTICE

If air-float does not work:

- If  is shown on the LCD screen, the air-float function cannot be used. Replace the batteries with new ones.
- Use a flathead screwdriver to turn the air-float adjustment screw, and adjust the airflow. Turning the screw right increases airflow, and turning it left reduces airflow. Adjust the amount relative to the installation location.

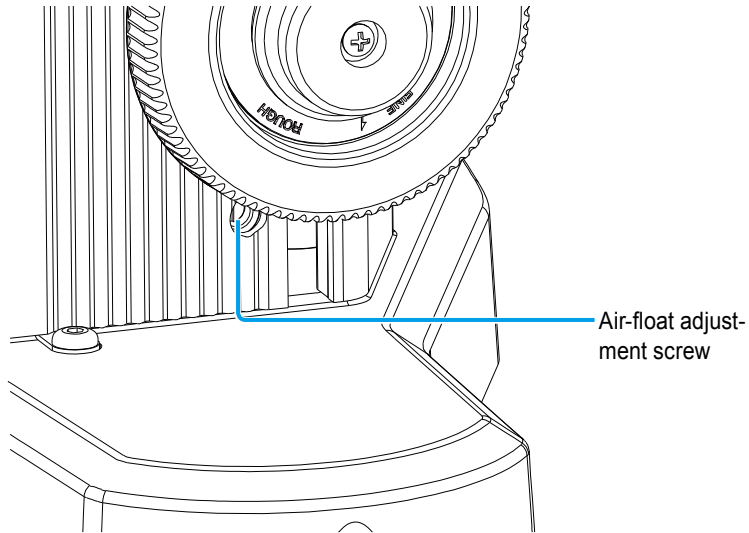

The airflow has been adjusted to provide optimal performance before shipment. We recommend using the default settings as much as possible.

### NOTICE

When adjusting the air-float flow:

- Due to the characteristics of the air-float mechanism, variations in airflow may cause the main unit to vibrate. In this case, reduce the airflow.
- If you adjust the airflow, make sure that the friction between the surface plate and the main unit is reduced before use.

# 1.4 Preparing Measurements

Complete the following setup before measuring.

- Reference setup
- Ball diameter setup

## 1.4.1 Reference Setup

Set the reference to use when measuring height. The dimensions measured from this reference will become the height measurements. This product supports absolute measurement (ABS) and incremental measurement (INC) for the reference setting. Use the method that matches your application.

- Absolute measurement (ABS) reference  
This method uses a user-defined value as the reference. When measuring the height from the surface plate, set the surface plate as the reference with a value of 0 mm.

Example: The surface plate is set as the reference at 0 mm.

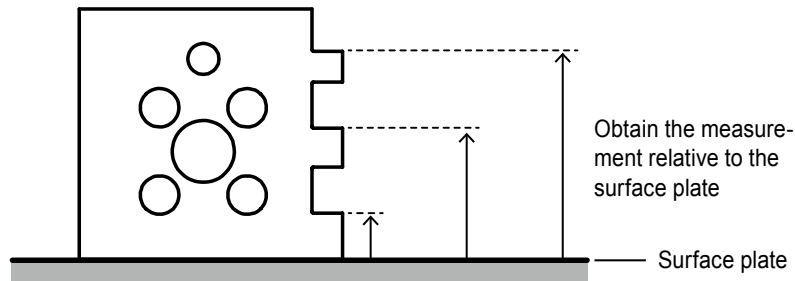

To use a reference other than the surface plate, assign that value as the reference.

Example: Surface a1 is set as the reference at 50 mm.

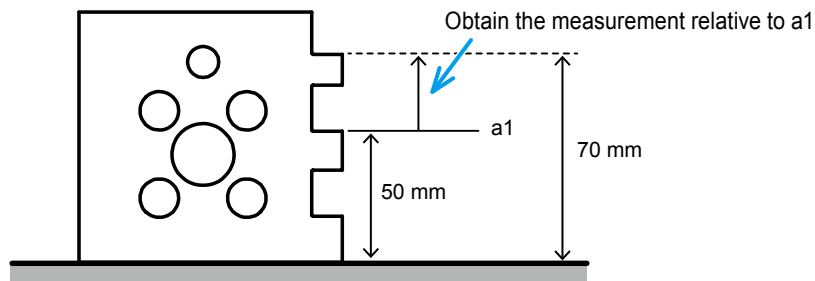

### Tips

For details about setting the ABS reference,  "■ ABS reference setup" (page 11)

## 1 Before Using This Product

- Incremental measurement (INC) reference

This method uses an arbitrary point on the workpiece as the reference. The specified point acts as the reference for the measurements and is assigned a value of 0 mm.

Example: Surface a1 is set as the reference (normally 0 mm).

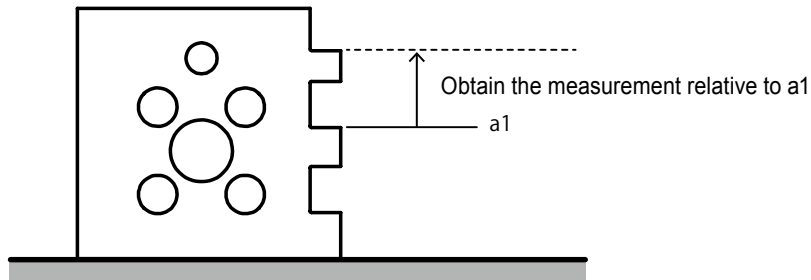

### Tips

For details about setting the INC reference,  "■ INC reference setup" (page 13)

## ■ ABS reference setup

- Setting the surface plate as the reference

1 Press .

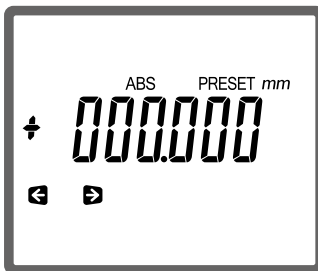

2 Confirm that [+000.000] is displayed on the LCD screen.

If a different value is displayed, use , , , or  to change the value to [+000.000].

### Tips

For details about configuring the settings,  "● Setting a point other than the surface plate as the reference" (page 12)

3 Slowly bring the ball of the probe into contact with the surface plate until a beep sound is made.

» Reference setup is complete.

## 1 Before Using This Product

### ● Setting a point other than the surface plate as the reference

As an example, the procedure for setting the reference to [+25.000 mm] using a 25 mm gauge block is explained below.

#### Tips

You can perform the settings using the dial test indicator or the dial indicator instead of the probe.

1 Press .

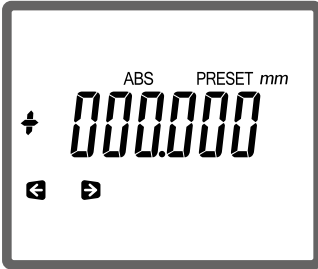

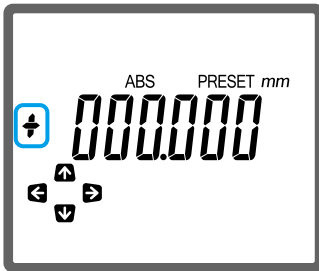

2 Press  to make [+] flash.

If [-] is displayed, press  or  to change it to [+].

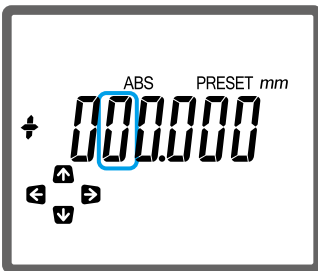

3 Repeatedly press  until the value in the 10s place flashes.



4 Press  or  to display [2].

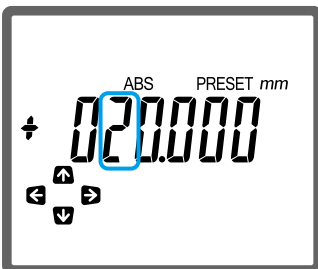

## 1 Before Using This Product

---

- 5 Display [5] in ones place using the same procedure described in steps 3 and 4.

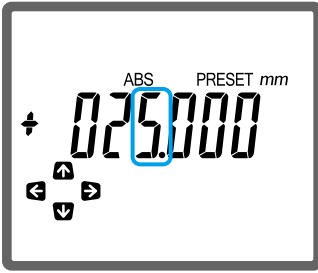

- 6 Slowly bring the ball of the probe into contact with the 25 mm gauge block until a beep sound is made.  
» Reference setup is complete.

### Tips

For measurements using a dial test indicator or dial indicator, bring the stylus into contact with the gauge block, and then press  to finish the setup.

## ■ INC reference setup

### Tips

If the power to the product is cut off by removing the batteries or the AC adapter (optional accessory) cable, the reference setting will be erased.

- 1 Press .



- 2 Slowly bring the ball of the probe into contact with the desired reference until a beep sound is made.  
» Reference setup is complete.

## 1.4.2 Ball Diameter Setup

The height is calculated using the distance moved by the bottom surface of the ball attached to the tip of the probe. (See the left figure below.)

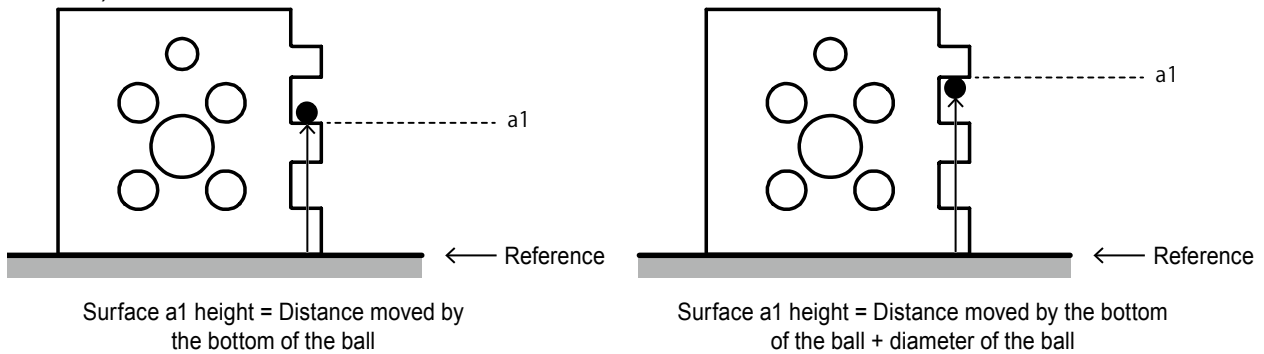

However, when measuring by making contact with the top of the ball, the height will be measured by adding the diameter of the ball to the distance moved by the bottom of the ball. (See the right figure below.)





The diameter of the ball must be set in advance. The following procedure explains how to measure the diameter of the ball using the provided ball diameter calibration block. This procedure is necessary if you are using the product for the first time or if you are replacing the probe.

### Tips

If using a gauge block, use one with a height of 20 mm or more.

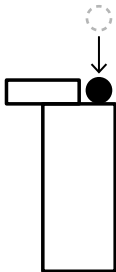
- 1 Press **MODE**.
  - » Characters and icons will be displayed in the bottom row of the LCD screen.
- 2 Press **MEAS** to select  (probe settings).
- 3 Press **ENTER**.
  - »  will be displayed on the upper left of the LCD screen.
- 4 Slowly bring the ball of the probe into contact with the following position on the ball diameter calibration block until a beep sound is made.



- »  will be displayed on the upper left of the LCD screen.

## 1 Before Using This Product

---

- 5** Slowly bring the ball into contact with the following position on the ball diameter calibration block until a beep sound is made.

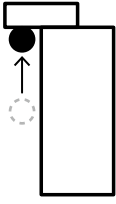

- 6** Press .

» Ball diameter setup is complete.

### NOTICE

- The actual dimensions of the ball diameter and the measured value may not match.
- When measuring, calculates the diameter of the ball and displays the result. The moment the ball is brought into contact with the workpiece, a beep will sound, and the displayed value may appear to jump, but this is not a malfunction.

**MEMO**

# 2 Basic Measuring Methods

Using the following workpiece as an example, the height, width, inner diameter, outer diameter, and plane displacement measuring methods will be explained. Before measuring, make preparations such as setting the reference.

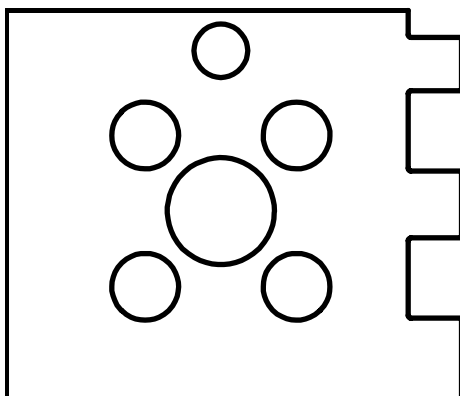

## Tips

For details about preparing measurements, see "1.4 Preparing Measurements" (page 10)

## 2.1 Measuring the Height

There are 2 types of height measurement: one where the ball of the probe is brought into contact with the top position of the workpiece for the top surface measurement, and one where the ball is brought into contact with the lower position for the bottom surface measurement. As an example, the procedure for measuring top surface height A (85 mm) and bottom surface height B (115 mm), shown below, using the surface plate as the ABS reference is explained.

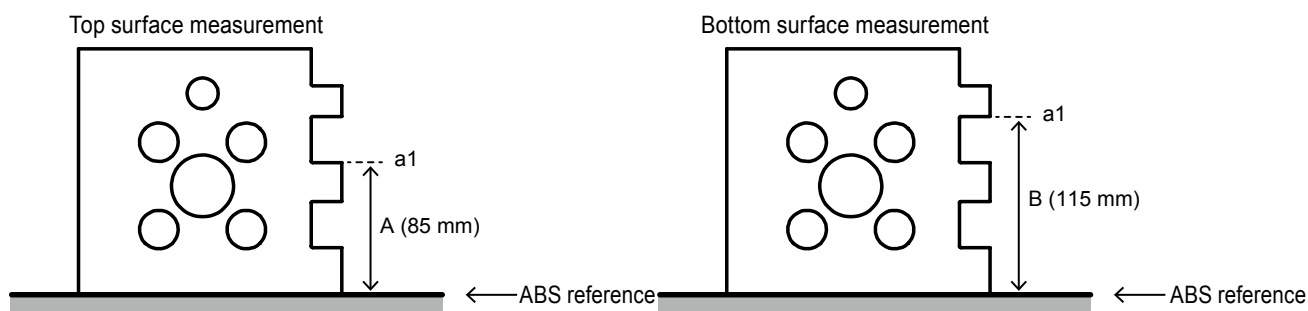

## Tips

For details about the ABS reference, see "1.4.1 Reference Setup" (page 10)

**1** Press and hold  to change to the ABS reference setting.

» [ABS] will be displayed on the LCD screen.

- 2** Bring the ball of the probe into contact with surface a1 until a beep sound is made.

Maintain contact with the ball.

Top surface measurement

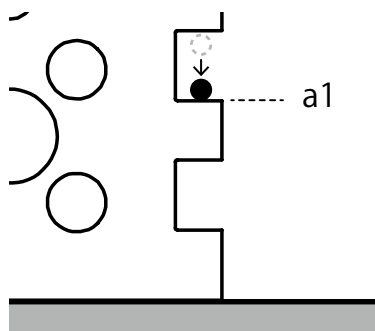

Bottom surface measurement

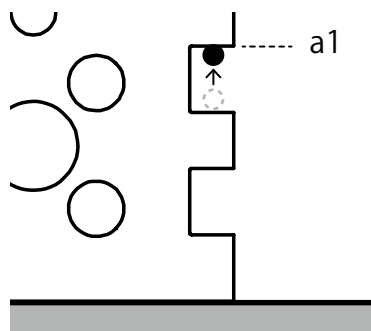

» When the measurement is complete, [H] and the measured value are displayed on the LCD screen.

### Tips

If the product is connected to any external devices, the measurement results will be automatically output. For details, see "3.9 Outputting Measurement Results to an External Device" (page 47)

- 3** Confirm the measurement.

Top surface measurement

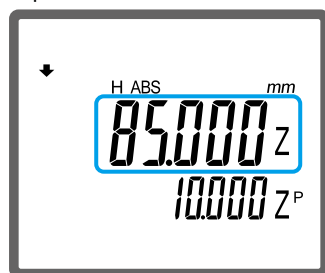

Bottom surface measurement



### Tips

The value next to [Z<sup>P</sup>] displayed in the bottom row of the LCD screen shows the difference between 2 measurements. For details, see "3.1 Calculating the Difference Between 2 Measurements" (page 31)

## 2.2 Measuring the Width

Measure the steps and the width of the grooves. As an example, the procedure for measuring the step of A (10 mm) and the groove width of B (30 mm), shown below, using a1 as the INC reference is explained.

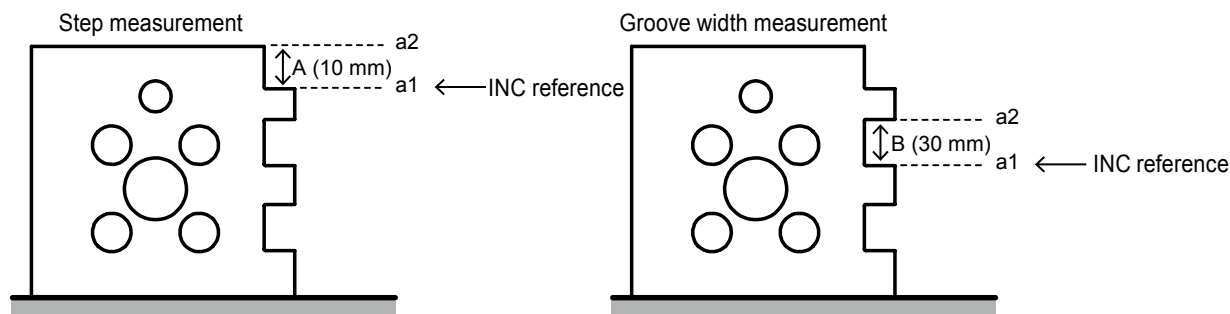

### Tips

For details about the INC reference, see "1.4.1 Reference Setup" (page 10)

**1** Press **ZERO ABS** to change to the INC reference setting.

» [INC] will be displayed on the LCD screen.

**2** Bring the ball of the probe into contact with surface a1 until a beep sound is made.

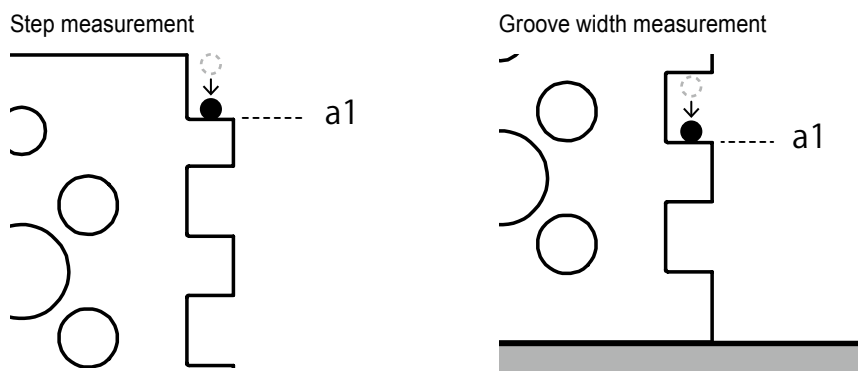

» [0.000] will be displayed on the LCD screen.

**3** Bring the ball into contact with surface a2 until a beep sound is made.

Maintain contact with the ball.

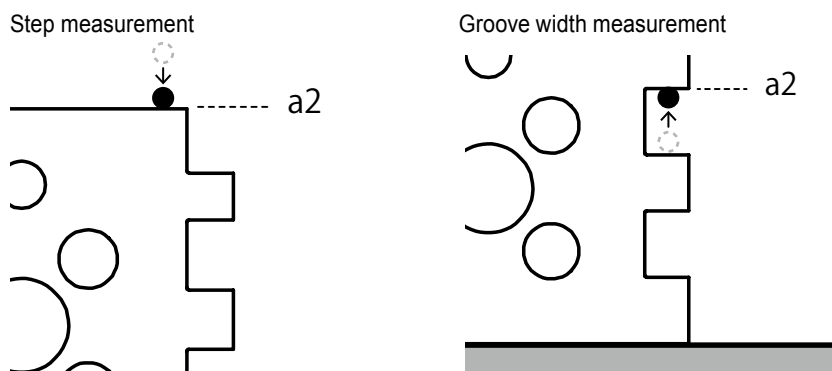

» When the measurement is complete, [H] and the measured value are displayed on the LCD screen.

### Tips

If the product is connected to any external devices, the measurement results will be automatically output. For details, [☰](#) "3.9 Outputting Measurement Results to an External Device" (page 47)

#### 4 Confirm the measurement.

Step measurement

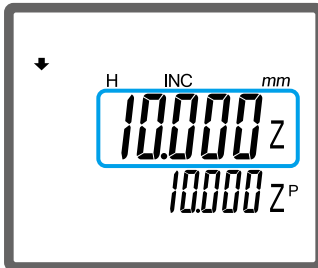

Groove width measurement

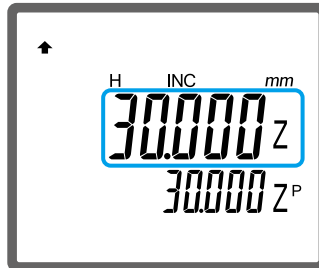

### Tips

The value next to [ZP] displayed in the bottom row of the LCD screen shows the difference between 2 measurements. For details, [☰](#) "3.1 Calculating the Difference Between 2 Measurements" (page 31)

## 2.3 Measuring the Inner Diameter

Measure the diameter (inner diameter) of a hole. For the inner diameter measurement, obtain the lowest and highest points of the hole to measure the distance. As an example, the procedure for measuring the inner diameter of A (40 mm), shown below, is explained.

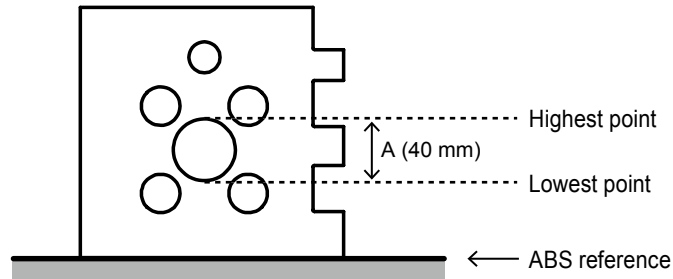

### Tips

Depending on the method set for terminating the scanning measurement, the operating procedures vary slightly. First, confirm the method set for terminating the scanning measurement. For details about changing the settings, see "3.4 Setting the Terminating Method for Scanning Measurements" (page 43)

1 Press .

»  will be displayed on the upper left of the LCD screen.

2 Obtain the lowest point of the hole.

**If the scanning measurement termination method is set to [Auto] (automatic termination)**

1 Face the ball of the probe towards the left or right of the center bottom surface of the hole, and slowly bring it into contact with the surface until a beep sound is made.

Maintain contact with the ball.

» [0.000] will be displayed on the LCD screen.

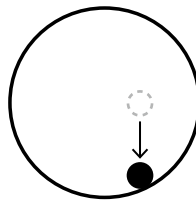

### NOTICE

Bring the ball into contact within 0.5 mm of the lowest point. Measuring with a wider range may increase measurement errors.

2 Secure the probe up/down wheel with your hand or the clamp screw in order to prevent it from moving.

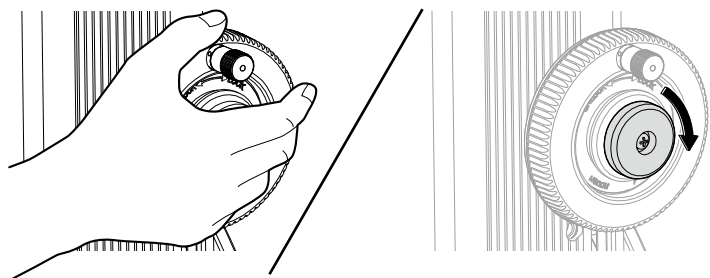

## 2 Basic Measuring Methods

- 3** Move the ball left or right so that it passes the center of the bottom surface of the hole. Perform this action until a beep sound is made.

» The measurement of the lowest point is complete, and  will be displayed on the upper left of the LCD screen.

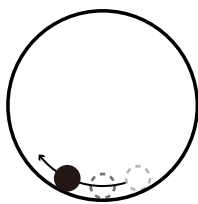

- 4** If you have tightened the clamp screw, loosen it.

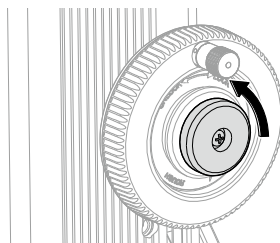

### If the scanning measurement termination method is set to [ENTER] (manual termination)

- 1** Face the ball of the probe towards the center of the bottom surface of the hole, and slowly bring it into contact with the surface until a beep sound is made. Maintain contact with the ball.

» [0.000] will be displayed on the LCD screen.

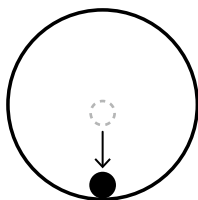

- 2** Secure the probe up/down wheel with your hand or the clamp screw in order to prevent it from moving.

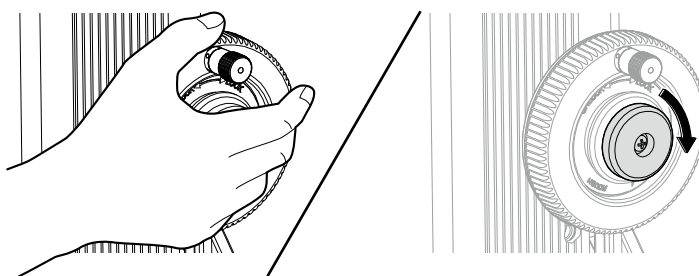

- 3** Repeatedly move the ball left and right.

» The value displayed on the LCD screen will change based on the vertical movement of the ball.

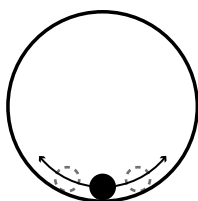

- 4** When the displayed value stops changing, press .

» The measurement of the lowest point is complete, and  will be displayed on the upper left of the LCD screen.

## 2 Basic Measuring Methods

- 5 If you have tightened the clamp screw, loosen it.

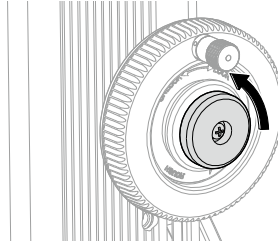

- 3 Obtain the highest point of the hole.

### If the scanning measurement termination method is set to [Auto] (automatic termination)

- 1 Face the ball towards the left or right of the center top surface of the hole, and slowly bring it into contact with the surface until a beep sound is made. Maintain contact with the ball.
  - » [0.000] will be displayed on the LCD screen.

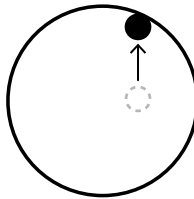

#### NOTICE

Bring the ball into contact within 0.5 mm of the highest point. Measuring with a wider range may increase measurement errors.

- 2 Secure the probe up/down wheel with your hand or the clamp screw in order to prevent it from moving.
- 3 Move the ball left or right so that it passes the center of the top surface of the hole. Perform this action until a beep sound is made.
  - » The measurement of the highest point is complete.
- 4 If you have tightened the clamp screw, loosen it.

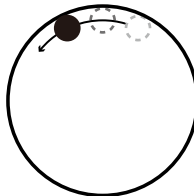

### If the scanning measurement termination method is set to [ENTER] (manual termination)

- 1 Face the ball towards the center of the top surface of the hole, and slowly bring it into contact with the surface until a beep sound is made. Maintain contact with the ball.
- 2 Secure the probe up/down wheel with your hand or the clamp screw in order to prevent it from moving.

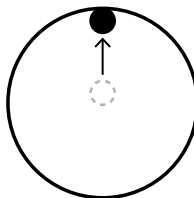

## 2 Basic Measuring Methods

---

- 3 Repeatedly move the ball left and right.
  - » The value displayed on the LCD screen will change based on the vertical movement of the ball.
- 4 When the displayed value stops changing, press .
- » The measurement of the highest point is complete.
- 5 If you have tightened the clamp screw, loosen it.

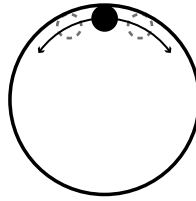

- 4 Confirm the measurement.

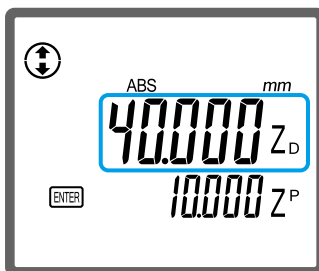

### Tips

- If the product is connected to any external devices, the measurement results will be automatically output. For details, see "3.9 Outputting Measurement Results to an External Device" (page 47)
- The value next to [ZP] displayed in the bottom row of the LCD screen shows the difference between 2 measurements. For details, see "3.1 Calculating the Difference Between 2 Measurements" (page 31)

- 5 To continue measuring press ; to finish measuring press .

## 2.4 Measuring the Outer Diameter

Measure the diameter (outer diameter) of a cylinder. For the outer diameter measurement, obtain the lowest and highest point of the cylinder to measure the distance. As an example, the procedure for measuring the outer diameter of A (20 mm), shown below, is explained.

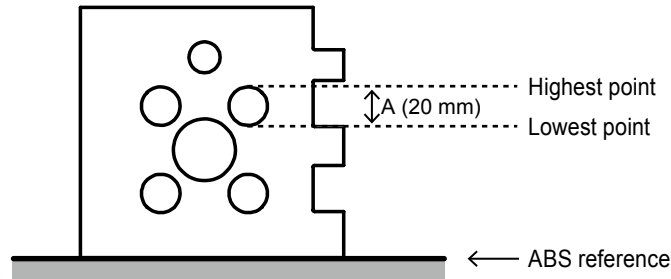

### Tips

Depending on the method set for terminating the scanning measurement, the operating procedures vary slightly. First, confirm the method set for terminating the scanning measurement. For details about changing the settings, see "3.4 Setting the Terminating Method for Scanning Measurements" (page 43)

1 Press .

»  will be displayed on the upper left of the LCD screen.

2 Obtain the lowest point of the cylinder.

**If the scanning measurement termination method is set to [Auto] (automatic termination)**

1 Face the ball of the probe towards the left or right of the center bottom surface of the cylinder, and slowly bring it into contact with the surface until a beep sound is made.

Maintain contact with the ball.

» [0.000] will be displayed on the LCD screen.

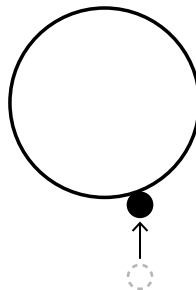

### NOTICE

Bring the ball into contact within 0.5 mm of the lowest point. Measuring with a wider range may increase measurement errors.

2 Secure the probe up/down wheel with your hand or the clamp screw in order to prevent it from moving.

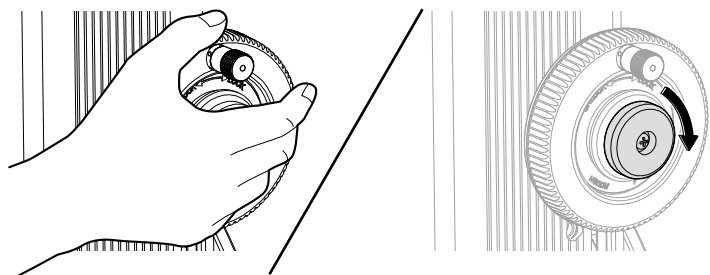

## 2 Basic Measuring Methods

- 3** Move the ball left or right so that it passes the center of the bottom surface of the cylinder. Perform this action until a beep sound is made.

» The measurement of the lowest point is complete, and  will be displayed on the upper left of the LCD screen.

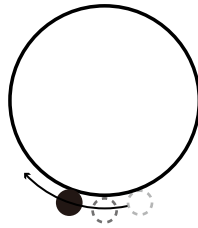

- 4** If you have tightened the clamp screw, loosen it.

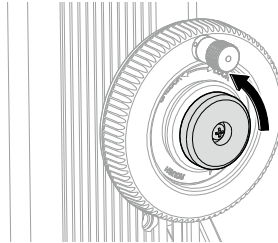

### If the scanning measurement termination method is set to [ENTER] (manual termination)

- 1** Face the ball of the probe towards the center of the bottom surface of the cylinder, and slowly bring it into contact with the surface until a beep sound is made. Maintain contact with the ball.

» [0.000] will be displayed on the LCD screen.

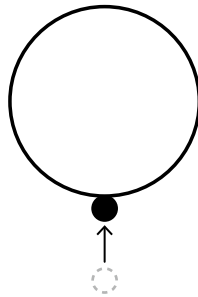

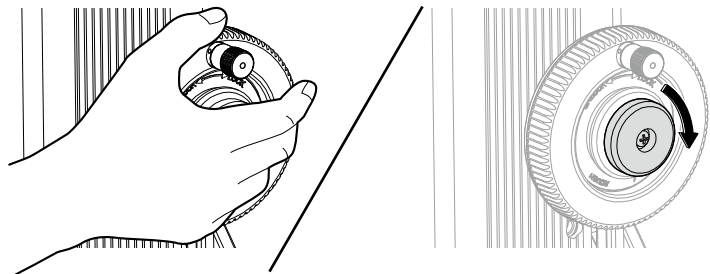

- 2** Secure the probe up/down wheel with your hand or the clamp screw in order to prevent it from moving.

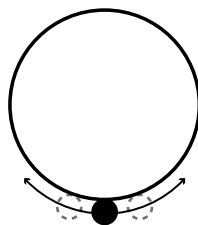

- 3** Repeatedly move the ball left and right.

» The value displayed on the LCD screen will change based on the vertical movement of the ball.



- 4** When the displayed value stops changing, press .

» The measurement of the lowest point is complete, and  will be displayed on the upper left of the LCD screen.

## 2 Basic Measuring Methods

- 5 If you have tightened the clamp screw, loosen it.

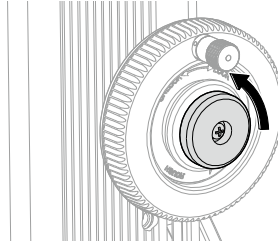

- 3 Obtain the highest point of the cylinder.

If the scanning measurement termination method is set to [Auto] (automatic termination)

- 1 Face the ball towards the left or right of the center top surface of the cylinder, and slowly bring it into contact with the surface until a beep sound is made. Maintain contact with the ball.
  - » [0.000] will be displayed on the LCD screen.

### NOTICE

Bring the ball into contact within 0.5 mm of the highest point. Measuring with a wider range may increase measurement errors.

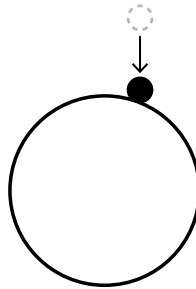

- 2 Secure the probe up/down wheel with your hand or the clamp screw in order to prevent it from moving.
- 3 Move the ball left or right so that it passes the center of the top surface of the cylinder. Perform this action until a beep sound is made.
  - » The measurement of the highest point is complete.
- 4 If you have tightened the clamp screw, loosen it.

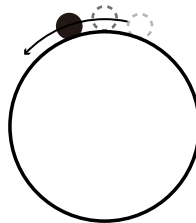

If the scanning measurement termination method is set to [ENTER] (manual termination)

- 1 Face the ball towards the center of the top surface of the cylinder, and slowly bring it into contact with the surface until a beep sound is made. Maintain contact with the ball.
- 2 Secure the probe up/down wheel with your hand or the clamp screw in order to prevent it from moving.

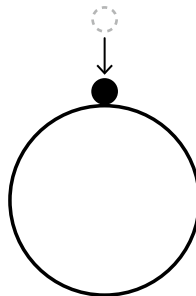

## 2 Basic Measuring Methods

---

- 3 Repeatedly move the ball left and right.  
» The value displayed on the LCD screen will change based on the vertical movement of the ball.

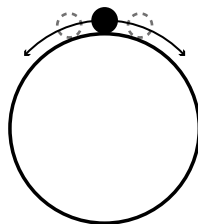

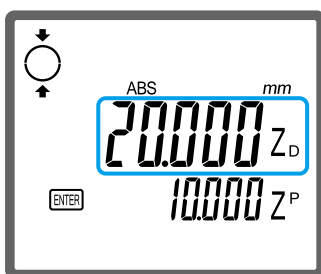

- 4 When the displayed value stops changing, press .  
» The measurement of the highest point is complete.
- 5 If you have tightened the clamp screw, loosen it.

- 4 Confirm the measurement.



### Tips

- If the product is connected to any external devices, the measurement results will be automatically output. For details,  "3.9 Outputting Measurement Results to an External Device" (page 47)
- The value next to [ZP] displayed in the bottom row of the LCD screen shows the difference between 2 measurements. For details,  "3.1 Calculating the Difference Between 2 Measurements" (page 31)

- 5 To continue measuring press ; to finish measuring press .

## 2.5 Measuring the Plane Displacement (Plane Scanning Measurement)

Moving the ball of the probe while maintaining contact with the surface of the workpiece obtains multiple measurements. Based on the acquired data, the maximum, minimum, and displacement values (maximum – minimum = displacement) can be measured.

As an example, the procedure for measuring the displacement of a1 (maximum value), a2 (minimum value), and A (1 mm), shown below, is explained.

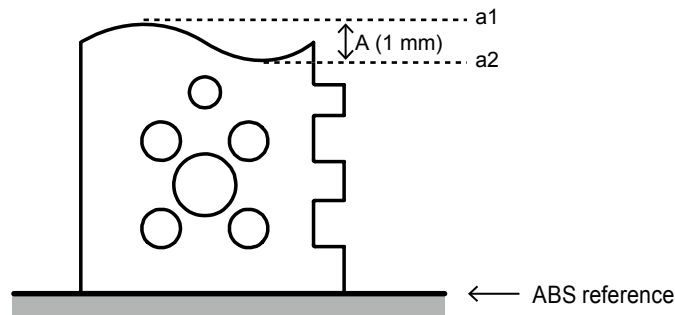

### NOTICE

Measure within a range of about 1 mm from the starting point. Measuring with a wider range may increase measurement errors.



**1** Press .

»  will be displayed on the upper left of the LCD screen.

**2** Begin measuring.

**1** Slowly bring the ball of the probe into contact with the measuring surface until a beep sound is made.

Maintain contact with the ball.

» [0.000] will be displayed on the LCD screen.

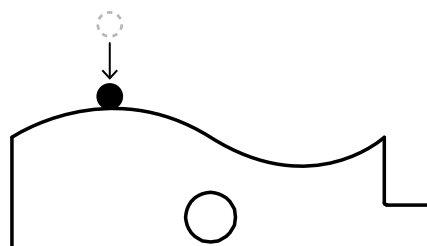

**2** Secure the probe up/down wheel with your hand or the clamp screw in order to prevent it from moving.

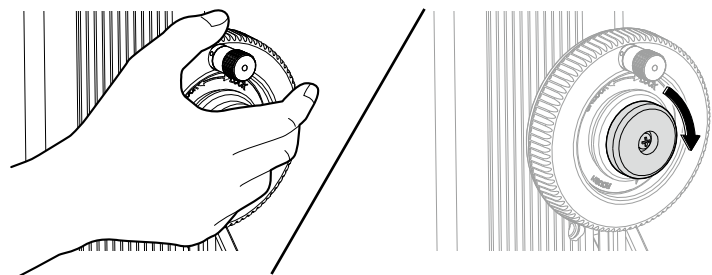

## 2 Basic Measuring Methods

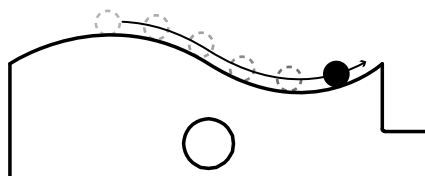

- 3 Move the ball while maintaining contact with the surface of the workpiece.
  - » The value displayed on the LCD screen will change based on the unevenness of the workpiece.
- 4 When the displayed value stops changing, press .
  - » The measurement is complete.



### Tips

If the product is connected to any external devices, the measurement results will be automatically output. For details, see "3.9 Outputting Measurement Results to an External Device" (page 47)

- 3 Check the measurement result.

- 1 Press  or .
- » With each key press, the value displayed on the LCD screen will change among displacement (W), minimum (ZS), maximum (ZL).

### Tips

The difference between the median displacement value and the previous measurement will be displayed in the bottom row of the LCD screen.

- 2 If you have tightened the clamp screw, loosen it.

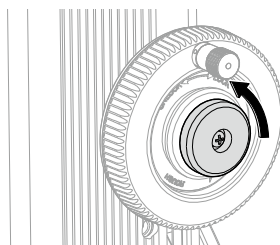
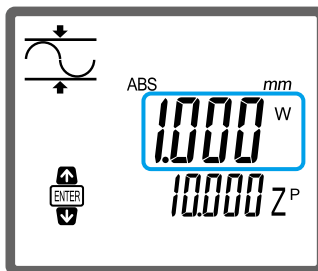

- 4 To continue measuring press ; to finish measuring press .

# 3 Specific Usage Applications

## 3.1 Calculating the Difference Between 2 Measurements

There are multiple methods for determining the measurement difference. Use the method that matches your application.

- Difference with the previous measurement

The difference between the current and immediately prior measurements will automatically be displayed in the bottom row of the LCD screen. For example, if the previous measurement was 25 mm and the current measurement is 45 mm, [20.000] will be displayed.

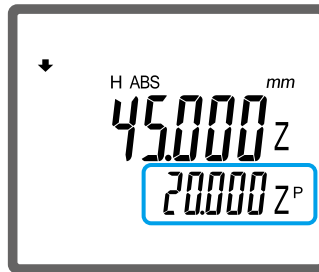

The difference with the previous measurement can be checked simply by reading the value displayed in the bottom row.

### Tips

For details, see "3.1.1 Determining the Difference Between the Most Recently Measured Value" (page 32)

- Difference with a user-defined point

A user-defined point can be set as the comparison point for measurements. For example, set the surface plate as the reference, and then while continually making measurements, the distance relative to the surface plate will be displayed each time in the bottom row of the LCD screen.

### Tips

For details, see "3.1.2 Continuously Measuring the Distance from One Specific Point to Multiple Other Points" (page 33)

- Difference between two measurements stored in memory

The two measurements are stored in the product's internal memory, and the difference between the two values is calculated. This memory storage method is useful for when you cannot calculate the measurement difference using the 2 previously described methods, such as obtaining a measurement difference with a value obtained 2 measurements ago.

### Tips

For details, see "3.1.3 Calculating the Difference Between Values Stored in the Memory" (page 35)

### 3.1.1 Determining the Difference Between the Most Recently Measured Value

Check the difference between the current and previous measurement by observing the value in the bottom row of the LCD screen. As an example, with the surface plate set as the ABS reference, the heights of a1, a2, and a3 are measured in that order, and the difference for each measurement can be checked.

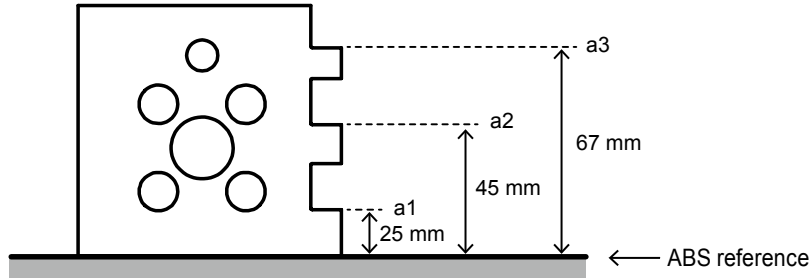

**Tips**

- For details about the ABS reference, see "1.4.1 Reference Setup" (page 10)
- For details about measuring height, see "2.1 Measuring the Height" (page 17)
- If an inner diameter, outer diameter, or plane scanning measurement is made, the median measurement will be used for comparisons. For example, if the inner diameter is measured sequentially for circles s1 and s2, the difference displayed in the bottom row of the LCD screen will be calculated using the median values (centers) of circle s1 and s2.

**1** Press and hold to change to the ABS reference setting.  
 » [ABS] will be displayed on the LCD screen.

**2** Measure the height of a1.



**3** Measure the height of a2.  
 » The difference with a1 is displayed in the bottom row.



#### 4 Measure the height of a3.

» The difference with a2 is displayed in the bottom row.



### 3.1.2 Continuously Measuring the Distance from One Specific Point to Multiple Other Points

Set an arbitrary point as the reference, and proceed to measure the distance continuously from that point. As an example, the procedure for continuously obtaining the distance between a1 (center height of circle s1) and a2 (center height of circle s2) shown below with the surface plate set as the reference is explained.

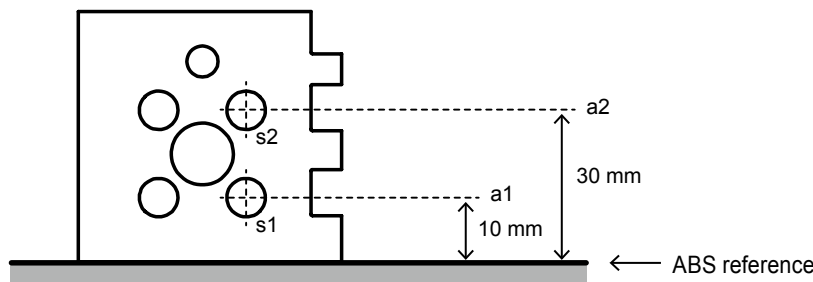

#### NOTICE

The following values can be set as the reference.

- Height measurement
- Median value of an inner or outer diameter measurement
- Median, minimum, or maximum value of a plane scanning measurement

#### 1 Set the reference.

- 1 Slowly bring the ball of the probe into contact with the surface plate until a beep sound is made. Maintain contact with the ball.





#### Tips

- Perform the same operation even if a point other than the height of the surface plate is set as the reference. (Bring the ball into contact with the point to set as the reference.)
- To set an inner diameter, outer diameter, or plane scanning measurement as the reference, make the appropriate measurement. For details, see "2.3 Measuring the Inner Diameter" (page 21), "2.4 Measuring the Outer Diameter" (page 25), "2.5 Measuring the Plane Displacement (Plane Scanning Measurement)" (page 29)

### 3 Specific Usage Applications

- 2 With the measurement displayed, press and hold  until a beep sound is made.
- » The surface plate is set as the reference.

#### Tips

- If you measured an inner or outer diameter in step 1, the median of that diameter will be set as the reference. If you made a plane scanning measurement, display the value that you want to set as the reference (median, minimum, maximum), and then press and hold .
- If you reversed the counting direction, follow the procedure in  "1.4.1 Reference Setup" (page 10) to set the reference again.
- If following the procedure in  "1.4.1 Reference Setup" (page 10) to set the reference again, first press and hold  until a beep sound is made, and then perform the procedure.
- If the power to the product is cut off by removing the batteries or the AC adapter (optional accessory) cable, the reference setting will be erased.

- 2 Measure the inner diameter of s1.
- » The distance between the surface plate and a1 is displayed in the bottom row.

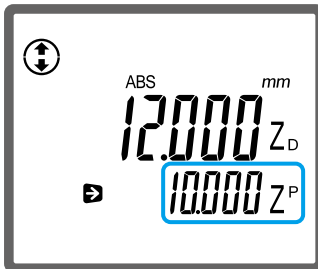

#### Tips

- For details about measuring inner diameters,  "2.3 Measuring the Inner Diameter" (page 21)
- If inner diameter, outer diameter, or plane scanning measurements are made, the median measurement will be set as the target value for determining distance.

- 3 Measure the inner diameter of s2.
- » The distance between the surface plate and a2 is displayed in the bottom row.

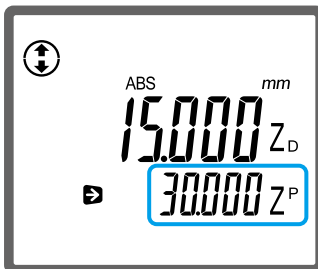

- 4 Press and hold  until a beep sound is made.
- » The reference setting is canceled, and the product returns to normal measuring mode.

### 3.1.3 Calculating the Difference Between Values Stored in the Memory

Store 2 measurements in the internal memory of the product, and then calculate the difference between them. Any measurements that are stored in the memory and are no longer needed can be erased as needed.

**Tips**

If the power to the product is cut off by removing the batteries or the AC adapter (optional accessory) cable, any values stored in the memory will be erased.

■ **Calculating the difference between 2 values stored in the memory**

As an example, the procedure for calculating the distance between a1 and a3 (42 mm), with the surface plate set as the ABS reference and heights measured at a1, a2, and a3, is explained.

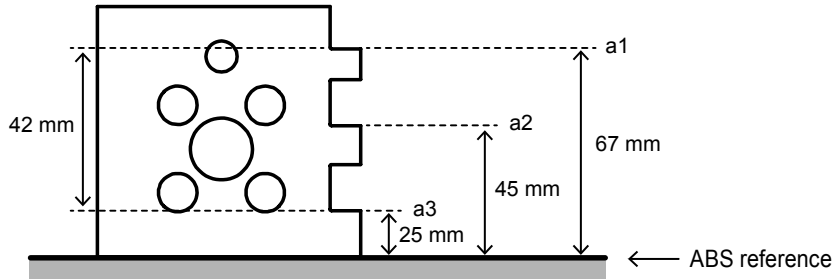

**Tips**

For details about the ABS reference, see "1.4.1 Reference Setup" (page 10)

- 1 Press and hold to change to the ABS reference setting.
  - » [ABS] will be displayed on the LCD screen.

- 2 Measure the height of a1.

**Tips**

For details about measuring height, see "2.1 Measuring the Height" (page 17)

- 3 With the measurement for a1 displayed, press and hold until a beep sound is made.
  - » The a1 measurement is stored in memory, and [M1] (memory 1), which shows the location of storage in the memory, is displayed on the bottom left of the LCD screen.

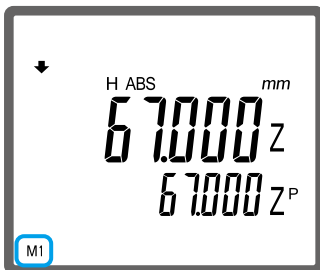

- 4 Measure the height of a2.

### 3 Specific Usage Applications

5 Measure the height of a3.

6 With the measurement for a3 displayed, press and hold  until a beep sound is made.

- » Measurement a3 is stored in the memory, and [M2] (memory 2), which indicates the location of storage in the memory, is displayed on the bottom left of the LCD screen.

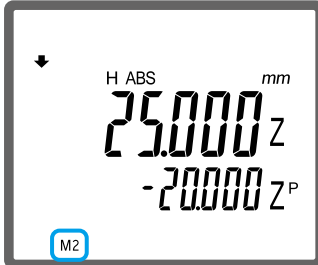

7 Press .

Proceed to the next step, and determine the difference between the two values stored in memory.

8 Press  2 times.

- » Characters will be displayed in the bottom row of the LCD screen.

9 Press  to select [M1/-M2] (memory calculation).

- » The difference between [M1] and [M2] will be displayed.

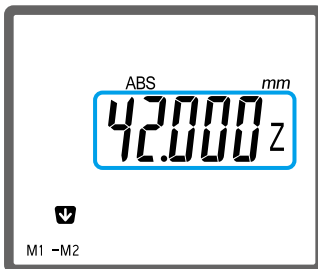

#### Tips

If you want to check the proportional difference between 2 measurements, press . The value of [M1] divided by [M2] will be displayed.

10 Press  2 times.

### ■ Erasing the measurement from memory

1 Press  2 times.

- » Characters will be displayed in the bottom row of the LCD screen.

2 Press  to select [M.CLR] (memory clear).

- » [M1] and [M2] will be displayed on the lower left of the LCD screen.

#### Tips

If measurements are not stored in memory, [M1], [M2], and [M.CLR] will not be displayed.

### 3 Specific Usage Applications



---

**3** Erase the measurements stored in the memory.

**Erasing both [M1] and [M2] from memory**

**1** Press .

**Erasing only either [M1] or [M2] from memory**

**1** Press  or  to select the target for deletion, and then press .

**4** Press .

## 3.2 Judging the Tolerance

By setting the upper and lower tolerance limits in advance, the acceptability judgment can be automatically performed. The acceptability judgment will be displayed on the LED and the LCD screen, meaning it can be easily determined whether the value falls within the tolerance range.

Operation panel



Red: Upper tolerance limit exceeded.  
 Orange: Lower tolerance limit exceeded.  
 Green: Within the tolerance range.

LCD screen



[+NG]: Upper tolerance limit exceeded.  
 [-NG]: Lower tolerance limit exceeded.  
 [GO]: Within the tolerance range.

To perform the acceptability judgment automatically, register the upper and lower tolerance limits, and then enable the acceptability judgment function.

### Tips

You can change the length of time that the LED is lit. For details about changing the settings, see "3.8 Setting the LED Lighting Time" (page 46)

### 3.2.1 Setting the Upper and Lower Limits

For example, the procedure for setting the upper [+100.010 mm] and lower [+99.995 mm] tolerance limits is explained below.

### Tips

- The set values are retained in memory even if the power is turned off.
- Be sure to set the upper limit value to a numeric value larger than the lower limit value. If a smaller value is set, there will be an error.

1 Press **MODE**.

» Characters and icons will be displayed in the bottom row of the LCD screen.

2 Press **MEM** to select [TOL.] (tolerance setting).

» [U] and the current upper limit will be displayed on the LCD screen.

3 Press **→** to make [+] flash.

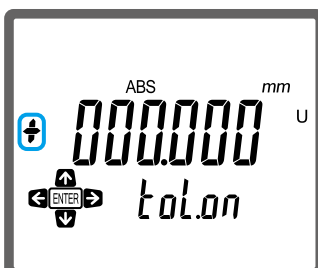

If [-] is displayed, press **↑** or **↓** to change it to [+].



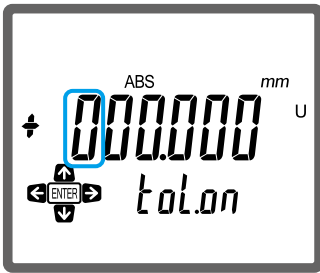

### 3 Specific Usage Applications

- 4 Repeatedly press  until the value in the 100s place flashes.

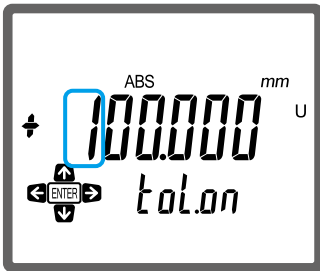

- 5 Press  or  to display [1].



- 6 With the same operations as in steps 4 to 5, set the second digit of the fractional part to display [1], and then press .

[L] and the current lower limit will be displayed on the LCD screen.

- 7 With the same operations as in steps 3 to 5, set the lower limit to [+99.995mm], and then press .
- » Setup is complete.

#### 3.2.2 Enabling/Disabling the Judgment Function



- 1 Press .

» Characters and icons will be displayed in the bottom row of the LCD screen.

- 2 Press  to select [TOL.] (tolerance setting).

» [U] and the current upper limit will be displayed on the LCD screen.

- 3 Press .

- 4 Press  or , to select [toL.on] (enabled) or [toL.oFF] (disabled), and then press .

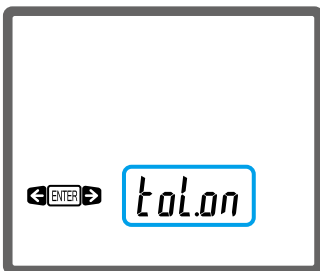

- 5 Press .

## 3.3 Simplifying Measurement Procedures

For example, if you want to make measurements in the following order: height at 4 points, inner diameter at 4 points, and outer diameter at 2 points. When performing multiple measurements in a set order, it is beneficial to register the procedure. Because the measurements are automatically performed following the order of the registered procedure, the overall operation is simplified.

The following measurement functions can be registered.





- Inner diameter measurement
- Outer diameter measurement
- Plane scanning measurement
- Bottom surface measurement
- Top surface measurement

### Tips

For details about each measurement function,  "2 Basic Measuring Methods" (page 17)

### 3.3.1 Registering a Measurement Procedure

Select the measurement functions, such as height and inner diameter, in the order they will be used, and register them. Up to 10 steps can be registered.



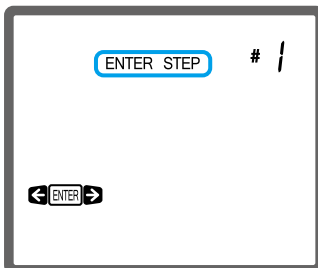

- 1 Press  2 times.  
» Characters will be displayed in the bottom row of the LCD screen.
- 2 Press  to select [ASSIST] (assist function).
- 3 Press  or  to select [ENTER STEP], and then press .



### 3 Specific Usage Applications

#### 4 Register a measurement procedure.

1 Refer to the following table. Press the key for the first measurement to be performed.

Measurement function	Setting key	Measurement function number
Inner diameter measurement		1
Outer diameter measurement		2
Plane scanning measurement		3
Bottom surface measurement		4
Top surface measurement		5

For example, to register an top surface measurement, press . In this case, [5] will be displayed for the measurement function number.

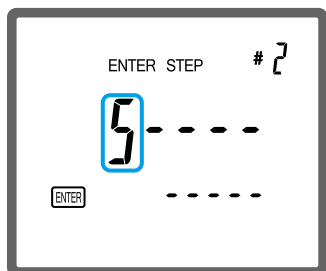

» Registering the first measurement is complete, and the flashing cursor moves to the right.

2 Register the subsequent steps using the same method.

» Setting the 10th step completes the registration. The measurement function registered to the 1st step will then automatically run.

#### Tips

To register 9 or fewer steps, press  to complete the registration process. The measurement function registered to the 1st step will then automatically run.

5 Proceed to step 4 in "3.3.2 Measuring Using a Registered Measurement Procedure" (page 42) to make the measurements.

Press  to terminate the operation.

## 3.3.2 Measuring Using a Registered Measurement Procedure

1 Press **MODE** 2 times.  
» Characters will be displayed in the bottom row of the LCD screen.

2 Press **ZERO ABS** to select [ASSIST] (assist function).

3 Press **←** or **→** to select [RUN], and then press **ENTER**.

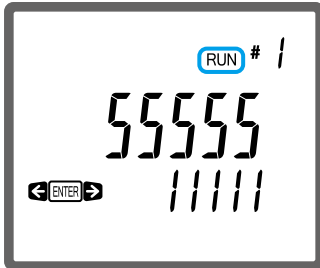

» The first registered measurement will be automatically performed.

4 Make the measurements.

1 Make the first measurement.

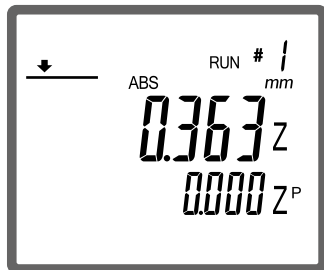

» The first registered measurement will finish, and then the second registered measurement will be performed.

### Tips

- For inner diameter, outer diameter, or plane scanning measurements, press **ENTER** to proceed to the next registered measurement.
- For details about making measurements, see "2 Basic Measuring Methods" (page 17)

2 Make the subsequent measurements.

» When the 10th measurement is made, all measurements will be finished.





5 To continue measuring press **ENTER**; to finish measuring press **CANCEL**.

# 3.4 Setting the Terminating Method for Scanning Measurements



A scanning measurement obtains multiple measurements by moving the ball of the probe while maintaining contact with the workpiece and calculates values such as the maximum and minimum values from among the measurements. This section explains how to specify the termination method for scanning measurements. This setting is applicable to inner and outer diameter measurements.

**Tips**

[Auto] (automatic termination) is the default setting.

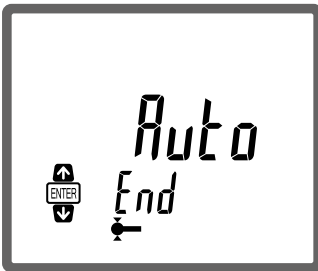
- 1 Press .
  - » Characters and icons will be displayed in the bottom row of the LCD screen.
- 2 Press  to select  (probe settings).
- 3 Press  or  to display the following screen.
  - » [Auto] (automatic termination) or [ENTER] (manual termination) will be displayed, depending on the current setting.



- 4 Press  or  to select the setting, and then press .

Setting	Details
[ENTER]	Press  to manually terminate the scanning measurement.
[Auto]	The scanning measurement automatically terminates when the ball of the probe elevates about 0.5 mm from the lowest point or lowers about 0.5 mm from the highest point of the hole or cylinder. When the measurement is complete, a beep sound is made.

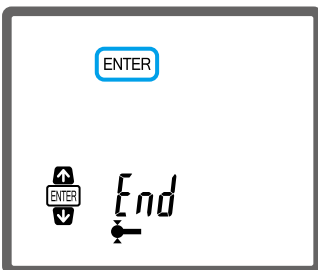

» Setup is complete.

**NOTICE**

If [Auto] (automatic termination) is set, ensure that the ball is set to pass through the lowest and highest points of the hole or cylinder. An accurate measurement result cannot be obtained if the ball does not pass through the lowest and highest points.

## 3.5 Holding the Displayed Measurement Results

You can hold a measurement on the display. Even if the ball of the probe moves away from the work-piece, the displayed value will not change until you release the hold function. This function is applicable to height and width measurements.

- 1 Measure the height or width.  
» [H] and the measurement will be displayed on the LCD screen.

### Tips

For details about measuring height and width, see "2.1 Measuring the Height" (page 17) and "2.2 Measuring the Width" (page 19)

- 2 Press  while [H] and the current measurement are displayed.  
» The displayed value is held.

### Tips





- Press  again to release the display.
- Even if you output measurement results to this product from externally connected devices, the display will not be released.

## 3.6 Setting the Resolution for Measurements

You can change the smallest reading (resolution) that the measuring instrument will display on the LCD screen.

### Tips

The default setting is [0.001 mm] for models that support millimeters and [0.00005 in] for models that support inches.

- 1 Press .  
» Characters and icons will be displayed in the bottom row of the LCD screen.
- 2 Press  to select [RES.] (resolution setting).
- 3 Press  or  to select the setting, and then press .

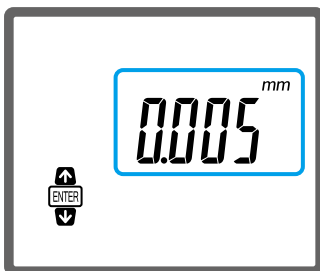





- » Setup is complete.

## 3.7 Setting the Time Until the Power Turns Off (Auto-Off)

Auto-off is a function that automatically turns off the product if it is not used for a specified period of time. This section explains how to set the length of time that must pass before the auto-off function is activated.

### Tips

[2min] (2 minutes) is the default setting.

- 1 Press  2 times.  
» Characters will be displayed in the bottom row of the LCD screen.
- 2 Press  to select [POWER SET] (power setting).
- 3 Press  or  to select the setting, and then press .

Setting	Details
[2min]	The power is turned off if there is no operation for 2 minutes.
[5min]	The power is turned off if there is no operation for 5 minutes.
[oFF]	Disables the auto-off function.

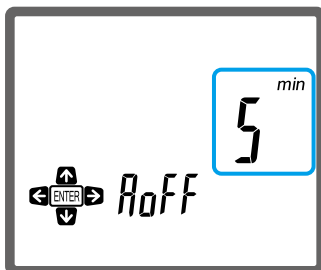

- » Setup is complete.

## 3.8 Setting the LED Lighting Time

Sets the time that the LED lights for tolerance judgment. If the battery is quickly depleted, we recommend changing the setting so that the LED is off.

### Tips

[3 SEc] (3 seconds) is the default setting.

- 1 Press **MODE** 2 times.  
» Characters will be displayed in the bottom row of the LCD screen.
- 2 Press **↓** to select [POWER SET] (power setting).
- 3 Press **←** or **→** to display [LEd].
- 4 Press **↑** or **↓** to select the setting, and then press **ENTER**.

Setting	Details
[3 SEc]	Lights for 3 seconds.
[ALL]	Stays continuously lit.
[oFF]	Turns off the light.

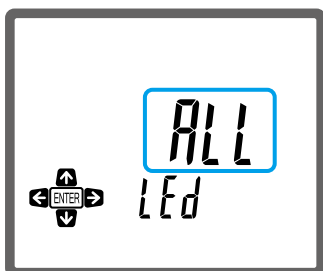

» Setup is complete.

## 3.9 Outputting Measurement Results to an External Device

Depending on the application of the measurement results data can be output to the optional mini printer or sent to the PC.

### 3.9.1 Outputting to a Mini Printer (Optional Accessory)





Connecting the optional Digimatic mini-processor to the Digimatic output connector of this product will allow you to output measurement results. The measurement results will automatically be output upon completion of measuring. However, you can also output data by pressing .

#### NOTICE

You can output measurement results when they are displayed. There is no output during a scanning measurement.

#### Tips



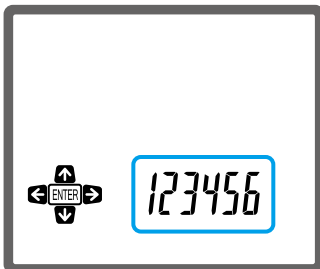

- You can also output measurement results by using optional external devices. For details, see the accompanying manual for the Digimatic mini-processor.
- By default, the product is set to output the value displayed in the top row of the LCD screen. Use the following procedure to change the setting to the bottom row.

- 1 Press .
  - » Characters and icons will be displayed in the bottom row of the LCD screen.
- 2 Press  to select [OUTPUT] (output setting).
- 3 Press  or  to select the bottom row, and then press .



» Setup is complete.

- Use the following procedure to specify how many digits of the measurement are output. You can specify either [out-d1] (Digimatic output) or [out-d2] (Digimatic 2 output), according to the number of digits that the external device you will connect can output. [out-d1] (Digimatic output) is the default setting.

- 1 Press .
  - » Characters and icons will be displayed in the bottom row of the LCD screen.
- 2 Press  to select [OUTPUT] (output setting).
- 3 Press  or  until [out-d\*] is displayed.

### 3 Specific Usage Applications

- 4 Press or to select the setting, and then press .

Setting	Details
[out-d1]	Outputs six digits of the measurement. If you will connect a device that does not support eight-digit output, choose this setting.
[out-d2]	Outputs eight digits of the measurement. If you will connect a device that supports eight-digit output, choose this setting.

» Setup is complete.

- If the resolution for models that support inches is set to [0.00005 in], you can change which digits in the measurement are output. By default, the lowest 6 digits are set to be output. For example, in [22.12345 in], [2.12345 in] will be output. Use the following procedure to change the output to the highest 6 digits.

- 1 Press .
- » Characters and icons will be displayed in the bottom row of the LCD screen.
- 2 Press to select [OUTPUT] (output setting).
- 3 Press or until [888888] is displayed.
- 4 Press or to select [88.8888] (the first 6 digits), and then press .
- » Setup is complete.

### 3.9.2 Outputting to a PC (Windows Only)

By connecting this product to your Windows PC using a micro USB cable, you can send measurement results to the PC. Results can be output to commercially-available communication software.

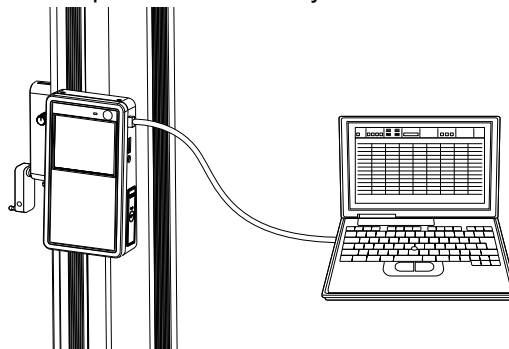

Before sending the data, the communication driver must be installed on the PC. The system requirements for the communication driver are provided below.

Items	Operating environment
OS	Windows 10/Windows 8/Windows 7/Windows Vista
HDD capacity	500 KB or more
Display	800 x 600 resolution or higher, 256 colors or more
Other	<ul style="list-style-type: none"> <li>• Communication software is required.</li> <li>• We recommend using the standard USB port on the main unit (the usage of other USB ports are not officially supported).</li> <li>• Internet access is required.</li> </ul>

#### Tips

Sending can also be done using the optional USB input tool, U-WAVE, etc. For details, see the accompanying manual for each product.

## ■ Installing the communication driver on your PC

- 1 Download the communication driver from our website.

<http://www.mitutoyo.co.jp/global.html>

- 2 Install the downloaded driver on the PC.

## ■ Sending the measurement results to your PC

- 1 Connect the product to your PC using a commercially available micro USB cable.

### **Tips**

When the cable is plugged in, the product is in the USB communication state, which depletes the battery. Remove the cable when not in use.

- 2 Start up communication software on the PC.



### **Tips**

The communication setups for the communication software should be subject to  "6.3.1 Communication Specification" (page 61).

- 3 Make a measurement.

» The measurement results will be automatically sent to the PC.

### **Tips**

- For details about measurement methods,  "2 Basic Measuring Methods" (page 17)
- You can also send the measurement results by pressing .





**MEMO**

# 4 Troubleshooting

If a problem occurs while using this product, please try one of the solutions provided below. If the solution does not work, contact our service department via your dealer for repair.

## 4.1 If the Following Problem Occurs

Based on the problem, determine the cause and the solution.

Problem	Cause	Solution
The power does not turn on when  is pressed.	<ul style="list-style-type: none"> <li>The batteries are not inserted correctly.</li> <li>The AC adapter (optional accessory) is not properly connected.</li> </ul>	<ul style="list-style-type: none"> <li>Reinsert the batteries.</li> <li>Reconnect the AC adapter (optional accessory).</li> </ul>
The battery quickly depletes.	The LED is set for continuous use.	<ul style="list-style-type: none"> <li>Change the setting of the LED lighting.</li> </ul> <p><b>Tips</b></p> <p>For details,  "3.8 Setting the LED Lighting Time" (page 46)</p> <ul style="list-style-type: none"> <li>Remove the batteries if the product will not be used for an extended period of time.</li> </ul>
The air-float function does not work (  is only lit when the air-float switch is pressed).	The batteries are too low for the air-float function to operate.	<ul style="list-style-type: none"> <li>Replace all 4 batteries with new ones.</li> <li>Connect an AC adapter (optional accessory).</li> </ul> <p><b>Tips</b></p> <ul style="list-style-type: none"> <li>The air-float function uses an excessive amount of electricity. If you use this function often, using the optional AC adapter is recommended.</li> <li>When using the air-float function, the battery life (until the air-float no longer functions) is around 1.5 hours.</li> </ul>
Measurements are not made even when the ball of the probe comes in contact with a workpiece (there is no beep sound).	The clamp knob is locked.	Loosen the clamp knob.
The displayed value is being held, and the workpiece cannot be measured ([H] is displayed on the LCD screen).	<ul style="list-style-type: none"> <li>The displayed value is held.</li> <li>The clamp knob is locked.</li> </ul>	<ul style="list-style-type: none"> <li>Press  to release the hold function.</li> <li>Follow the instructions in "■ When the displayed value is held, and the workpiece cannot be measured" (page 52) to loosen the clamp knob.</li> </ul>
There is variance in the measurements.	<ul style="list-style-type: none"> <li>The probe clamp knob is loosened.</li> <li>The ball of the probe contacted the workpiece with excessive force.</li> </ul>	<ul style="list-style-type: none"> <li>Tighten the probe clamp knob.</li> <li>Slowly bring the ball into contact with the workpiece.</li> </ul>

## 4 Troubleshooting

Problem	Cause	Solution
The probe vibrates when making plane scanning measurements.	The probe may vibrate depending on the condition of the surface of the workpiece.	Change the movement direction of the probe, and if the vibration stops, limit the movements to that direction.
<ul style="list-style-type: none"> <li>The displayed values flicker or disappear temporarily.</li> <li>An accurate measurement result cannot be obtained.</li> <li>The power is turned off automatically.</li> </ul>	The product is used in environments where electromagnetic interference exceeds requirements defined in the EMC Directive.	<ul style="list-style-type: none"> <li>The product will return to normal after removing the electromagnetic interference caused by electrostatic discharge.</li> <li>If this problem is due to electromagnetic interference acting on the AC or DC power line, check the circumference of the power line, and then make a measurement again.</li> <li>If a brownout occurs, the product will return to normal after the recovery from the low voltage.</li> </ul>

### ■ When the displayed value is held, and the workpiece cannot be measured

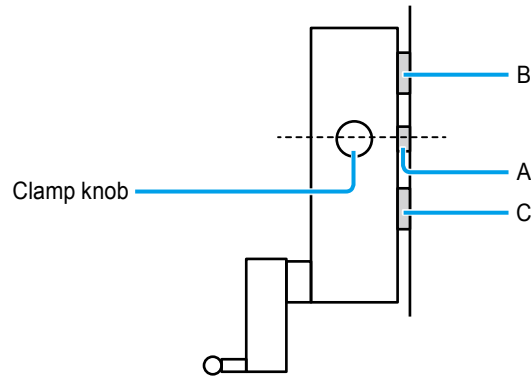

Ensure that metal fitting A of the probe is in the center between metal fitting B and C.



If metal fitting A is not in the center, turn the clamp knob left, and move metal fitting A vertically into the center. From this position, turn the clamp knob right as far as possible, and then turn it left about 5 rotations. The hold function will be released, and measurements can be made again.

## 4.2 If Error Messages Are Displayed

Based on the error displayed on the LCD screen, determine the cause and the solution.

Error message	Cause	Solution
	A battery has died.	<ul style="list-style-type: none"> <li>• Replace all 4 batteries with new ones.</li> <li>• Connect an AC adapter (optional accessory).</li> </ul>
Err-30F	The displayed value exceeds the number of displayable digits.	This error will automatically be corrected when the value falls within the displayable range.
<ul style="list-style-type: none"> <li>• XXX XXE (X is an arbitrary value)</li> <li>• Err-48A</li> </ul>	Positioning detection sensor error (e.g.: a foreign substance is present or an impact caused misalignment)	The sensor may have a failure. If the display is not restored even when the probe is stopped, contact the nearest Mitutoyo sales office or service center.
Err-90t	The lower limit set for the tolerance is higher than the upper limit.	<p>Set the lower limit so that it is below the upper limit.</p> <p><b>Tips</b> For details,  "3.2.1 Setting the Upper and Lower Limits" (page 38)</p>
Err-96P	A negative value is set for the ball diameter.	<p>Retry the ball diameter setting.</p> <p><b>Tips</b> For details,  "1.4.2 Ball Diameter Setup" (page 14)</p>
Err-40S	A critical error has occurred.	Contact our service department via your dealer for repair.

**MEMO**

# 5 Maintenance

- Clean the main unit, base, or probe by wiping it with a lint-free cloth or paper towel dampened with a neutral detergent. Do not use an organic solvent such as a thinner.
- In order to prevent dirt and dust accumulation, we recommend covering the main unit with the included product cover.

**MEMO**

# 6 Specifications

## 6.1 Basic Specifications

Code No.	Metric	518-240	518-242	518-244	518-246
	Inch/Metric	518-241	518-243	518-245	518-247
Model number	Metric	QMH-350AX	QMH-600AX	QMH-350BX	QMH-600BX
	Inch/Metric	QMH-14"AX	QMH-24"AX	QMH-14"BX	QMH-24"BX
Measuring range (Stroke)		0 mm to 465 mm (350 mm/14")	0 mm to 715 mm (600 mm/24")	0 mm to 465 mm (350 mm/14")	0 mm to 715 mm (600 mm/24")
Resolution	Metric	0.001 mm / 0.005 mm			
	Inch/Metric	0.001 mm / 0.005 mm / 0.00005" / 0.0001" / 0.0002"			
Accuracy (20 °C)	Indication accuracy* <sup>1</sup>	$\pm (2.4 + 2.1 L/600) \mu\text{m}$			
	Repeatability* <sup>1</sup>	$2\sigma \leq 1.8 \mu\text{m}$			
Perpendicularity (forward and backward direction) <sup>2</sup> (20 °C)		7 $\mu\text{m}$	12 $\mu\text{m}$	7 $\mu\text{m}$	12 $\mu\text{m}$
Guiding method		Roller bearing			
Driving method		Manual (wheel drive)			
Detection method		Electromagnetic induction absolute encoder			
Measuring force		$1.5 \pm 0.5 \text{ N}$			
Data output		Digimatic output / Digimatic 2 output / USB <sup>3</sup>			
Air-float		N/A		Available (only for the purpose of moving the unit) <sup>4</sup>	
Power supply		AA alkaline batteries x 4 (included), AC adapter (optional), rechargeable nickel-hydride batteries x 4 are supported <sup>5</sup>			
Estimated battery life <sup>6</sup>	Continuous use (air-float not used)	LED not set to constantly lit: About 1200 hours LED set to constantly lit <sup>9</sup> : About 100 hours			
	Regular use <sup>7</sup> (air-float not used)	LED not set to constantly lit: About 80 days LED set to constantly lit <sup>9</sup> : About 13.5 days			
	Air-float used <sup>8, 9</sup>	-		LED not set to constantly lit: About 3.8 days LED set to constantly lit: The battery life will be reduced to about 2/3 of the above value.	
Mass (kg)		25 kg	29 kg	25 kg	29 kg
Dimensions (mm)		QMH-350AX/QMH-350BX/QMH-14"AX/QMH-14"BX : 280 (W) x 273 (D) x 784 (H) QMH-600AX/QMH-600BX/QMH-24"AX/QMH-24"BX : 280 (W) x 273 (D) x 1016 (H)			
Operating temperature range (recommended)		0 °C to 40 °C (10 °C to 30 °C)			
Operating humidity range		20 % to 80 % RH (with no condensation)			
Storage temperature range		-10 °C to 50 °C			

## 6 Specifications

Storage humidity range	5 % to 90 % RH (with no condensation)
CE marking	EMC Directive EN61326-1 Immunity test requirement: Clause 6.2 Table 2 Emission limit: Class B RoHS Directive EN50581

- <sup>\*1</sup> The indication accuracy and repeatability indicate the values obtained from the height measurement of a flat surface using the standard  $\varnothing 5$  stepped probe. In the case of diameter, maximum (minimum) value, displacement, or circular pitch measurement, the measured value may be larger than the accuracy ratings listed in the table due to variation in the measuring force during the scanning measurement compared to the height measurement.
- <sup>\*2</sup> Perpendicularity indicates the value that is obtained from the measurement of a flat surface placed parallel with the datum base using the Lever Head (MLH-521) and Mu-checker (M-551).
- <sup>\*3</sup> A communication driver is required.  
It can be downloaded from our homepage. <http://www.mitutoyo.co.jp/global.html>  
For details, please refer to the instruction manual.
- <sup>\*4</sup> To use models equipped with the air-float function, use a surface plate of JIS1 Class or above. If a scratched or uneven surface is used, the specified performance may not be achieved.
- <sup>\*5</sup> The AC adapter cannot be used to recharge rechargeable batteries.
- <sup>\*6</sup> The life of the battery will vary depending on how the product is used.  
Recommended nickel hydride batteries: 1,900 mAh or greater capacity
- <sup>\*7</sup> Indicates calculated values assumed when the product is used for about 5 hours per day.
- <sup>\*8</sup> Indicates calculated values assumed when the product is used for about 0.5 hours per day.
- <sup>\*9</sup> If the constant LED or air-float functions will be frequently used, using the optional AC adapter is recommended.

# 6.2 Digimatic Data Output Specification

## 6.2.1 Data Format

### ■ Digimatic output

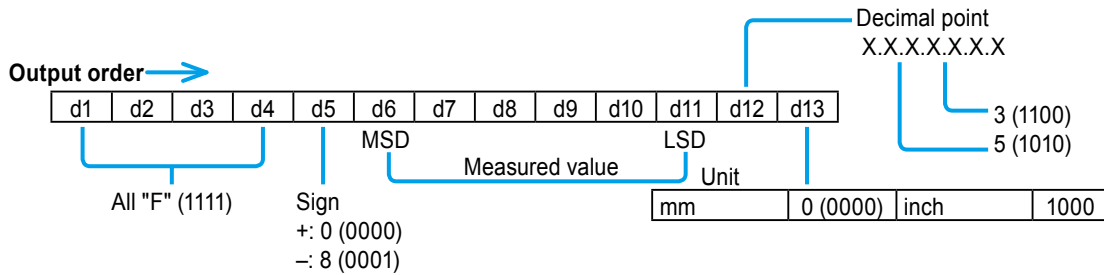

(Example) At a normal measurement of 0.123 mm

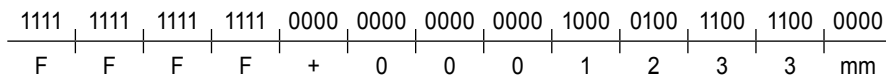

### ■ Digimatic 2 output

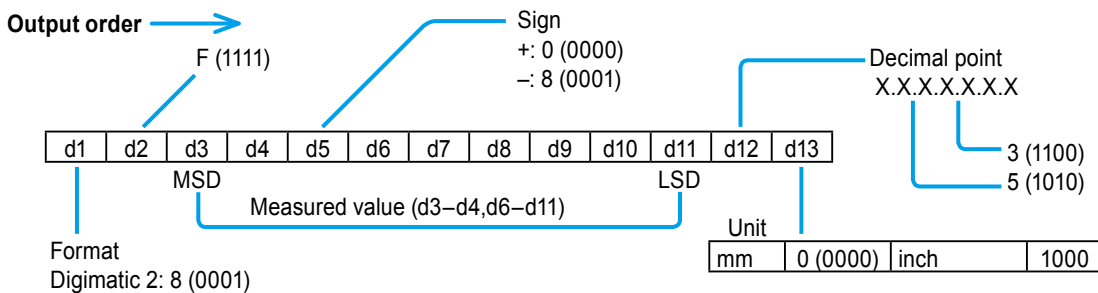

(Example) At a normal measurement of 0.123 mm

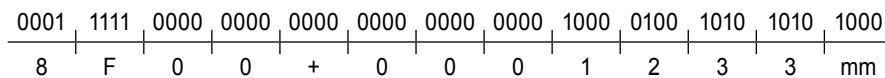

### Tips

- For details about specifying the number of output digits, see "3.9.1 Outputting to a Mini Printer (Optional Accessory)" (page 47)
- 7 digits are enabled when the resolution is set to [0.00005 in]. Due to our Digimatic data output specifications, all of these digits cannot be output simultaneously. Generally, the value in the 10s place (the highest value position) will be excluded, and only the remaining 6 digits will be output. However, it is possible to change the settings so that the digit with the highest value is output. For details, see "3.9.1 Outputting to a Mini Printer (Optional Accessory)" (page 47)

### 6.2.2 Connector Specification

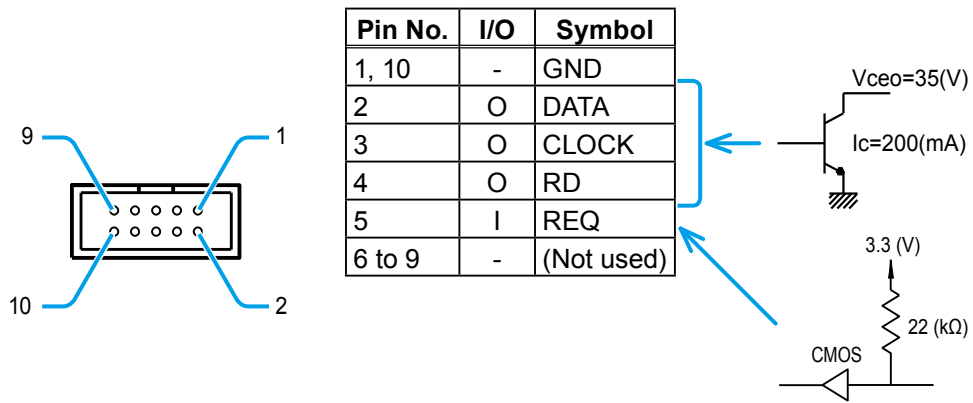

### 6.2.3 Timing Chart

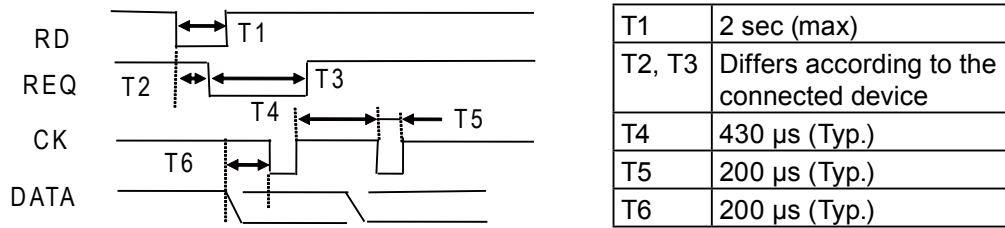

## 6.3 USB Data Output Specification

### 6.3.1 Communication Specification

Communication method	Half-duplex communication
Communication speed	9600 bps
Start bit	1
Data bit	8
Parity bit	N/A
Stop bit	1

### 6.3.2 Data Format

D1	Code No.	"0" (fixed)
D2	Channel No.	"1" (fixed)
D3	Measurement item	"A" (fixed)
D4	"+" or "-" sign	
D5 to D12	DATA (floating decimal point)	
D13	Carriage return	

### 6.3.3 Connector Specification

Pin No.	Signal name	Name
1	Vbus	Power supply (5 V) from the PC
2	D-	Communication with the PC (-)
3	D+	Communication with the PC (+)
4	N.C.	Connected to signal GND
5	GND	Signal GND

### 6.3.4 Data Format Examples

Unit system	Resolution	Output format
mm	0.001	0.123 → 01A+0000.123[CR]
	0.005	0.125 → 01A+0000.125[CR]
inch	0.00005	0.12345 → 01A+00.12345[CR]
	0.0001	0.1234 → 01A+000.1234[CR]
	0.0002	0.1234 → 01A+000.1234[CR]

## 6.4 Accessories

### ■ Standard accessories

Part No.	Accessory name	Quantity
05HZA148	ø5 stepped probe	1
12AAA715	Ball diameter calibration block	1
06AEW407	Rubber cap (A)	2
06AEW408	Rubber cap (B)	1
06AEX945	Cable clamp	1
06AEW863 <sup>*1</sup>	Product cover	1
06AEW864 <sup>*2</sup>	Product cover	1
05HAA412	Hexagonal wrench (size 5)	1
-	AA alkaline batteries <sup>*3</sup>	4
99MAF600B	User's Manual	1
99MAF601M	Setup Manual	1
99MAF602M	Quick Reference Manual	1
-	Certificate of Inspection	1
-	Warranty Card	1

<sup>\*1</sup> QMH-350AX/QMH-350BX/QMH-14"AX/QMH-14"BX only

<sup>\*2</sup> QMH-600AX/QMH-600BX/QMH-24"AX/QMH-24"BX only

<sup>\*3</sup> Products with "-1" at the end of their code numbers do not include batteries.

#### NOTICE

The supplied batteries are used only for the purpose of checking the functions and performance of the product. Therefore, they may not fulfill the specified battery life.

### ■ Fastening parts for transportation

Part No.	Accessory name	Quantity
05HZA196	Column fastening screw	2
06AEW164	Weight fastening screw	1
06AEW165	Probe fastening board	1
05HAA632	Hexagonal socket head cap screw (M6 x 25)	1

## 6.5 Optional Accessories

Part No.	Accessory name
<b>• Depth measuring probe</b>	
12AAC072	Depth probe
<b>• Interchangeable contact point for <math>\varnothing 5</math> stepped probe</b>	
957261	$\varnothing 2$ ball contact point (coaxial type)
957262	$\varnothing 3$ ball contact point (coaxial type)
957263	$\varnothing 4$ ball contact point (coaxial type)
957264	$\varnothing 14$ disk contact point
957265	$\varnothing 20$ disk contact point
12AAA788	$\varnothing 4$ ball contact point (eccentric type)
12AAA789	$\varnothing 6$ ball contact point (eccentric type)
<b>• Special holder, special probe</b>	
12AAA792	Holder for dial gauge
12AAA793	Long holder
<b>• AC adapter</b>	
06AFZ950JA or 06AEG180JA	AD620JA (for Japan/U.S.)
06AFZ950D or 06AEG180D	AD620D (for EU)
06AFZ950E or 06AEG180E	AD620E (for England)
06AFZ950K or 06AEG180K	AD620K (for Korea)
06AFZ950DC or 06AEG180DC	AD620DC (for China)
<b>• Digimatic connection cable</b>	
936937	1 m
965014	2 m
<b>• Others</b>	
05HZA143	9 x 9 adapter (the following clamp is required)
05GZA033	Clamp (for 9 x 9 adapter)
05HZA144	6.35 x 12.7 adapter (the following clamp is required)
901385	Clamp (for 6.35 x 12.7 adapter)
02AZE990	U-WAVE mounting plate
05HZA173	Scriber <sup>*1</sup>

\*1 The scriber is used for making measurements. It cannot be used for markings.

### NOTICE

The gauge blocks may be required for zero-setting depending on the probes and contact points to be used.

**MEMO**

---

# SERVICE NETWORK

\*As of Oct. 2018

## Europe

### Mitutoyo Europe GmbH

Borsigstrasse 8-10, 41469 Neuss, GERMANY  
TEL: 49 (0)2137 102-0 FAX: 49 (0)2137 102-351

### Mitutoyo CTL Germany GmbH

Von-Gunzert-Strasse 17, 78727 Oberndorf, GERMANY  
TEL: 49 (0)7423 8776-0 FAX: 49 (0)7423 8776-99

### KOMEG Industrielle Messtechnik GmbH

Zum Wasserwerk 3, 66333 Völklingen, GERMANY  
TEL: 49 (0)6898 91110 FAX: 49 (0)6898 911100

## Germany

### Mitutoyo Deutschland GmbH

Borsigstrasse 8-10, 41469 Neuss, GERMANY  
TEL: 49 (0)2137 102-0 FAX: 49 (0)2137 86 85

### M3 Solution Center Hamburg

Tempowerkring 9-im HIT-Technologiepark 21079  
Hamburg, GERMANY  
TEL: 49 (0)40 791894-0 FAX: 49 (0)40 791894-50

### M3 Solution Center Berlin

Carl-Scheele-Straße 16, 12489 Berlin, GERMANY  
TEL:49(0)30 2611 267

### M3 Solution Center Eisenach

Heinrich-Ehrhardt-Platz 1, 99817 Eisenach,GERMANY  
TEL: 49 (0)3691 88909-0 FAX: 49 (0)3691 88909-9

### M3 Solution Center Ingolstadt

Marie-Curie-Strasse 1a, 85055 Ingolstadt, GERMANY  
TEL: 49 (0)841 954920 FAX: 49 (0)841 9549250

### M3 Solution Center Leonberg

Steinbeisstrasse 2, 71229 Leonberg, GERMANY  
TEL: 49 (0)7152 6080-0 FAX: 49 (0)7152 608060

### Mitutoyo-Messgeräte Leonberg GmbH

Heidenheimer Strasse 14, 71229 Leonberg, GERMANY  
TEL: 49 (0)7152 9237-0 FAX: 49 (0)7152 9237-29

## U.K.

### Mitutoyo (UK) Ltd.

Joule Road, West Point Business Park,  
Andover, Hampshire SP10 3UX, UNITED KINGDOM  
TEL: 44 (0)1264 353 123 FAX: 44 (0)1264 354883

### M3 Solution Center Coventry

Unit6, Banner Park, Wickmans Drive, Coventry,  
Warwickshire CV4 9XA, UNITED KINGDOM  
TEL: 44 (0)2476 426300 FAX: 44 (0)2476 426339

### M3 Solution Center Halifax

Lowfields Business Park, Navigation Close, Elland,  
West Yorkshire HX5 9HB, UNITED KINGDOM  
TEL: 44 (0)1422 375566 FAX: 44 (0)1422 328025

### M3 Solution Center East Kilbride

The Baird Building, Rankine Avenue, Scottish  
Enterprise Technology Park, East Killbride G75  
0QF, UNITED KINGDOM  
TEL: 44 (0)1355 581170 FAX: 44 (0)1355 581171

## France

### Mitutoyo France

Paris Nord 2-123 rue de la Belle Etoile, BP 59267  
ROISSY EN FRANCE 95957 ROISSY CDG  
CEDEX, FRANCE  
TEL: 33 (0)149 38 35 00

### M3 Solution Center LYON

Parc Mail 523, cours du 3éme millénaire, 69791  
Saint-Priest, FRANCE  
TEL: 33 (0)149 38 35 70

### M3 Solution Center STRASBOURG

Parc de la porte Sud, Rue du pont du péage,  
67118 Geispolsheim, FRANCE  
TEL: 33 (0)149 38 35 80

### M3 Solution Center CLUSES

Espace Scionzier 480 Avenue des Lacs, 74950  
Scionzier, FRANCE  
TEL: 33 (0)1 49 38 35 90

### M3 Solution Center TOULOUSE

Aeroparc Saint Martin Cellule B08 ZAC de Saint  
Martin du Touch 12 rue de Caulet 31300  
Toulouse, FRANCE  
TEL: 33 (0)1 49 38 42 90

### M3 Solution Center RENNES

ZAC Mivoie  
Le Vallon  
35230 Noyal-Châtillon sur Seiche, FRANCE  
TEL: 33 (0)1 49 38 42 10

---

## Italy

### **MITUTOYO ITALIANA S.r.l.**

Corso Europa, 7 - 20020 Lainate (MI), ITALY  
TEL: 39 02 935781 FAX: 39 02 9373290•93578255

### **M3 Solution Center BOLOGNA**

Via dei Carpini1/A - 40011 Anzola Emilia (BO), ITALY  
TEL: 39 02 93578215 FAX: 39 02 93578255

### **M3 Solution Center CHIETI**

Contrada Santa Calcagna - 66020 Rocca S. Giovanni (CH), ITALY  
TEL: 39 02 93578280 FAX: 39 02 93578255

### **M3 Solution Center PADOVA**

Via G. Galilei 21/F - 35035 Mestrino (PD), ITALY  
TEL: 39 02 93578268 FAX: 39 02 93578255

## Belgium / Netherlands

### **Mitutoyo BeNeLux**

#### **Mitutoyo Belgium N.V.**

Hogenakkerhoekstraat 8, 9150 Kruibeke, BELGIUM  
TEL: 32 (0)3-2540444 FAX: 32(0)3-2540445

#### **Mitutoyo Nederland B.V.**

Wiltonstraat 25, 3905 KW Veenendaal,  
THE NETHERLANDS  
TEL: 31(0)318-534911

## Sweden

### **Mitutoyo Scandinavia AB**

Släntvägen 6, 194 61 Upplands Väsby, SWEDEN  
TEL: 46 (0)8 594 109 50 FAX: 46 (0)8 590 924 10

### **M3 Solution Center Alingsås**

Ängsvaktaregatan 3A, 441 38 Alingsås, SWEDEN  
TEL: 46 (0)8 594 109 50 FAX:46 (0)322 63 31 62

### **M3 Solution Center Värnamo**

Storgatsbacken 1, 331 30 Värnamo, SWEDEN  
TEL: 46 (0)8 594 109 50 FAX: 46 (0)370 463 34

## Switzerland

### **Mitutoyo (Schweiz) AG**

Steinackerstrasse 35, 8902 Urdorf, SWITZERLAND  
TEL: 41 (0)447361150 FAX: 41(0)447361151

### **Mitutoyo (Suisse) SA**

Rue Galilée 4, 1400 Yverdon-les Bains, SWITZERLAND  
TEL: 41 (0)244259422 FAX: 41 (0)447361151

## Poland

### **Mitutoyo Polska Sp.z o.o.**

Ul.Graniczna 8A, 54-610 Wroclaw, POLAND  
TEL: 48 (0)71354 83 50 FAX: 48 (0)71354 83 55

## Czech Republic

### **Mitutoyo Česko s.r.o.**

Dubská 1626, 415 01 Teplice, CZECH REPUBLIC  
TEL: 420 417-514-011 FAX: 420 417-579-867

### **Mitutoyo Česko s.r.o. M3 Solution Center Ivančice**

Ke Karlovu 62/10, 664 91 Ivančice, CZECH REPUBLIC  
TEL: 420 417-514-011 FAX: 420 417-579-867

### **Mitutoyo Česko s.r.o. M3 Solution Center Ostrava Mošnov**

Mošnov 314, 742 51 Mošnov, CZECH REPUBLIC  
TEL: 420 417-514-050 FAX:420 417-579-867

### **Mitutoyo Česko s.r.o. Slovakia Branch**

Hviezdoslavova 124, 017 01 Povážská  
Bystrica, SLOVAKIA  
TEL: 421 948-595-590

## Hungary

### **Mitutoyo Hungária Kft.**

Záhony utca 7, D-épület / fsz, 1031 Budapest, HUNGARY  
TEL: 36 (0)1 2141447 FAX: 36 (0)1 2141448

## Romania

### **Mitutoyo Romania SRL**

1A Drumul Garii Odai Street, showroom, Ground  
Floor, 075100 OTOPENI-ILFOV, ROMANIA  
TEL: 40 (0)311012088 FAX: +40 (0)311012089

### **Showroom in Brasov**

Strada Ionescu Crum Nr.1, Brasov Business  
Park Turnul 1, Mezanin, 500446  
Brasov-Judetul Brasov, ROMANIA  
TEL/FAX: 40 (0)371020017

## Russian Federation

### **Mitutoyo RUS LLC**

13 Sharikopodshipnikovskaya, bld.2,  
115088 Moscow, RUSSIAN FEDERATION  
TEL: 7 495 7450 752

## Finland

### **Mitutoyo Scandinavia AB Finnish Branch**

Viherkiitäjä 2A, 33960, Pirkkala, FINLAND  
TEL: 358 (0)40 355 8498

## Austria

### **Mitutoyo Austria GmbH**

Johann Roithner Straße 131 A-4050 Traun, AUSTRIA  
TEL: 43 (0)7229 23850 FAX: 43 (0)7229 23850-90

### **Götzis Regional Showroom**

Lasten Straße 48A 6840, AUSTRIA

---

## Singapore

**Mitutoyo Asia Pacific Pte. Ltd.**

**Head office / M3 Solution Center**

24 Kallang Avenue, Mitutoyo Building,  
SINGAPORE 339415

TEL:(65)62942211 FAX:(65)62996666

## Malaysia

**Mitutoyo (Malaysia) Sdn. Bhd.**

**Kuala Lumpur Head Office / M3 Solution Center**

Mah Sing Integrated Industrial Park, 4, Jalan Utarid U5/14,  
Section U5, 40150 Shah Alam, Selangor, MALAYSIA

TEL:(60)3-78459318 FAX:(60)3-78459346

**Penang Branch office / M3 Solution Center**

No.30, Persiaran Mahsuri 1/2, Sunway Tunas,  
11900 Bayan Lepas, Penang, MALAYSIA

TEL:(60)4-6411998 FAX:(60)4-6412998

**Johor Branch office / M3 Solution Center**

No. 70, Jalan Molek 1/28, Taman Molek, 81100  
Johor Bahru, Johor, MALAYSIA

TEL:(60)7-3521626 FAX:(60)7-3521628

## Thailand

**Mitutoyo(Thailand)Co., Ltd.**

**Bangkok Head Office / M3 Solution Center**

76/3-5, Chaengwattana Road, Kwaeng Anusaowaree,  
Khet Bangkaen, Bangkok 10220, THAILAND

TEL:(66)2-080-3500 FAX:(66)2-521-6136

**Chonburi Branch / M3 Solution Center**

7/1, Moo 3, Tambon Bowin, Amphur Sriracha,  
Chonburi 20230, THAILAND

TEL:(66)2-080-3563 FAX:(66)3-834-5788

**Amata Nakorn Branch / M3 Solution Center**

700/199, Moo 1, Tambon Bankao, Amphur Phan-  
thong, Chonburi 20160, THAILAND

TEL:(66)2-080-3565 FAX:(66)3-846-8978

## Indonesia

**PT. Mitutoyo Indonesia**

**Head Office / M3 Solution Center**

Jalan Sriwijaya No.26 Desa cibatu Kec. Cikarang  
Selatan Kab. Bekasi 17530, INDONESIA

TEL: (62)21-2962 8600 FAX: (62)21-2962 8604

## Vietnam

**Mitutoyo Vietnam Co., Ltd**

**Hanoi Head Office / M3 Solution Center**

No. 07-TT4, My Dinh - Me Tri Urban Zone, My Dinh 1  
Ward, Nam Tu Liem District, Hanoi, VIETNAM

TEL:(84)24-3768-8963 FAX:(84)24-3768-8960

**Ho Chi Minh City Branch Office / M3 Solution Center**

123 Dien Bien Phu Street,Ward 15,Binh Thanh  
District, Ho Chi Minh City, VIETNAM

TEL:(84)28-3840-3489 FAX:(84)28-3840-3498

## Mitutoyo Philippines, Inc.

**Head Office / M3 Solution Center**

Unit 2103, Bldg 2 GMV Building 2, 107 North Main Avenue,  
Laguna Technopark, Binan, Laguna 4024, Philippines

TEL:(63)49 544 0272 FAX:(63)49 544 0272

## India

**Mitutoyo South Asia Pvt. Ltd.**

**Head Office / M3 Solution Center**

C-122, Okhla Industrial Area, Phase-I,  
New Delhi-110 020, INDIA

TEL:91(11)2637-2090 FAX:91(11)2637-2636

**MSA Gurgaon technical center**

Plot No. 65, Phase-IV, Udyog Vihar, Gurgaon – 122016

TEL : 91 (0124) – 2340294

**Mumbai Region Head office**

303, Sentinel Hiranandani Business Park Powai,  
Mumbai-400 076, INDIA

TEL:91(22)2570-0684, 837, 839 FAX:91(22)2570-0685

**Pune Office / M3 Solution Center**

G2/G3, Pride Kumar Senate, F.P. No. 402 Off.  
Senapati Bapat Road, Pune-411 016, INDIA

TEL:91(20)6603-3643, 45, 46 FAX:91(20)6603-3644

**Bengaluru Region Head office / M3 Solution Center**

No. 5, 100 Ft. Road, 17th Main, Koramangala,  
4th Block, Bengaluru-560 034, INDIA

TEL:91(80)2563-0946, 47, 48 FAX:91(80)2563-0949

**Chennai Office / M3 Solution Center**

No. 624, Anna Salai Teynampet, Chennai-600 018, INDIA

TEL:91(44)2432-8823, 24, 27, 28

FAX:91(44)2432-8825

**Kolkata Office**

Unit No. 1208,Om Tower, 32,J.L..Nehru Road,  
Kolkata-700 071, INDIA

Tel: 91 33-22267088/40060635 Fax: (91) 33-22266817

**Ahmedabad Office/M3 Solution Center (Ahmedabad)**

A-104 & A-105, First Floor, Solitaire Corporate  
Park, Near Divya Bhaskar Press, S.G. Road,  
Ahmedabad - 380 015, INDIA

TEL: (91) 079 - 29704902/903

**Coimbatore Office (Coimbatore)**

Regus, Srivari Srimath, 3rd Floor, Door No:1045,  
Avinashi Road, Coimbatore - 641 018,INDIA

TEL: (91) 9345005663

---

## Taiwan

**Mitutoyo Taiwan Co., Ltd. / M3 Solution Center Taipei**  
4F., No.71, Zhouzi St., Neihu Dist., Taipei City 114,  
TAIWAN (R.O.C.)  
TEL:886(2)5573-5900 FAX:886(2)8752-3267

**Taichung Branch / M3 Solution Center Taichung**  
1F., No.758, Zhongming S. Rd., South Dist.,  
Taichung City 402, TAIWAN(R.O.C.)  
TEL:886(4)2262-9188 FAX:886(4) 2262-9166

**Kaohsiung Branch / M3 Solution Center Kaohsiung**  
1F., No.31-1, Haibian Rd., Lingya Dist.,  
Kaohsiung City 802, TAIWAN (R.O.C.)  
TEL:886(7)334-6168 FAX:886(7)334-6160

## South Korea

**Mitutoyo Korea Corporation**  
**Head Office / M3 Solution Center**  
(Sanbon-Dong, Geumjeong High View Build.), 6F, 153-8,  
Ls-Ro, Gunpo-Si, Gyeonggi-Do, 15808 KOREA  
TEL:82(31)361-4200 FAX:82(31)361-4202

**Busan Office / M3 Solution Center**  
(3150-3, Daejeo 2-dong) 8,Yutongdanji 1-ro  
49beon-gil, Gangseo-gu, Busan, 46721 KOREA  
TEL:82(51)718-2140 FAX:82(51)324-0104

**Daegu Office / M3 Solution Center**  
(Galsan-dong, Daegu Business Center), 301-Ho, 217,  
Seongseogongdan-ro, Dalseo-gu, Daegu 42704 KOREA  
TEL:82(53)593-5602 FAX:82(53)593-5603

## China

**Mitutoyo Measuring Instruments (Shanghai) Co., Ltd.**  
12F, Nextage Business Center, No.1111  
Pudong South Road, Pudong New District,  
Shanghai 200120, CHINA  
TEL:86(21)5836-0718 FAX:86(21)5836-0717

**Suzhou Office / M3 Solution Center (Suzhou)**  
No. 46 Baiyu Road, Suzhou 215021, CHINA  
TEL:86(512)6522-1790 FAX:86(512)6251-3420

**Wuhan Office**  
Room 1701, Wuhan Wanda Center, No. 96,  
Linjiang Road, Wuchang District, Wuhan  
Hubei 430060, CHINA  
TEL:86(27)8544-8631 FAX:86(27)8544-6227

**Chengdu Office**  
1-701, New Angle Plaza, 668# Jindong Road,  
Jinjiang District, Chengdu, Sichuan 610066, CHINA  
TEL:86(28)8671-8936 FAX:86(28)8671-9086

## Hangzhou Office

Room 804, Eastern International Business Cen-  
ter Building 1, No.600 Jinsha Road  
Hangzhou Economic and Technological  
Development Zone, 310018, CHINA  
TEL: 86(571)8288-0319 FAX: 86(571)8288-0320

**Tianjin Office / M3 Solution Center Tianjin**  
Room D 12/F, TEDA Building, No.256 Jie-fang  
Nan Road Hexi District, Tianjin 300042, CHINA  
TEL:86(22)5888-1700 FAX:86(22)5888-1701

**Changchun Office**  
Room 815, 8F, Building A1, Upper East  
International No.3000 Dongsheng Street,  
Erdao District, Changchun, Jilin, 130031, CHINA  
TEL:86(431)8192-6998 FAX:86(431)8192-6998

**Chongqing Office**  
Room 1312, Building 3, Zhongyu Plaza, No.86,  
Hongjin Avenue, Longxi Street, Yubei District,  
Chongqing, 400000, CHINA  
TEL:86(23)6595-9950 FAX:86(23)6595-9950

**Qingdao Office**  
Room 638, 6F, No.192 Zhengyang Road, Chengyang  
District, Qingdao, Shandong, 266109, CHINA  
TEL:86(532)8096-1936 FAX:86(532)8096-1937

**Xi'an Office**  
Room 805, Xi'an International Trade Center, No.  
196 Xiaozhai East Road, Xi'an, 710061, CHINA  
TEL:86(29)8538-1380 FAX:86(29)8538-1381

**Dalian Office / M3 Solution Center Dalian**  
Room 1008, Grand Central IFC, No.128 Jin ma Road,  
Economic Development Zone, Dalian 116600, CHINA  
TEL:86(411)8718 1212 FAX:86(411)8754-7587

**Zhengzhou Office**  
Room1801,18/F,Unit1,Building No.23, Shangwu Inner  
Ring Road, Zhengdong New District, Zhengzhou City,  
Henan Province, 450018, CHINA  
TEL:86(371)6097-6436 FAX:86(371)6097-6981

**Mitutoyo Leepport Metrology (Hong Kong) Limited**  
Room 818, 8/F, Vanta Industrial Centre, No.21-33, Tai  
Lin Pai Road, Kwai Chung, NT, Hong Kong  
TEL:86(852)2992-2088 FAX:86(852)2670-2488

**Mitutoyo Leepport Metrology (Dongguan) Lim-  
ited / M3 Solution Center Dongguan**  
No.26, Guan Chang Road, Chong Tou Zone,  
Chang An Town, Dong Guan, 523855 CHINA  
TEL:86(769)8541 7715 FAX:86(769)-8541 7745

**Mitutoyo Leepport Metrology (Dongguan) Limited – Fuzhou office**

Room 2104, City Commercial Centre, No.129 Wu Yi Road N., Fuzhou City, Fujian Province, CHINA  
TEL 86 591 8761 8095 FAX 86 591 8761 8096

**Mitutoyo Leepport Metrology (Dongguan) Limited – Changsha office**

Room 2207, Shiner International Plaza, No. 88, Kaiyuan Middle Road, Changsha City, Hunan, China  
TEL 86 731 8401 9276 FAX 86 731 8401 9376

**Mitutoyo Measuring Instruments (Suzhou) Co., Ltd.**

No. 46 Baiyu Road, Suzhou 215021, CHINA  
TEL:86(512)6252-2660 FAX:86(512)6252-2580

**U.S.A.**

**Mitutoyo America Corporation**

965 Corporate Boulevard, Aurora, IL 60502, U.S.A.  
TEL:1-(630)820-9666 Toll Free No. 1-(888)648-8869  
FAX:1-(630)978-3501

**M3 Solution Center-Illinois**

965 Corporate Boulevard, Aurora, IL 60502, U.S.A.  
TEL:1-(888)648-8869 FAX:1-(630)978-3501

**M3 Solution Center-Ohio**

6220 Hi-Tek Court, Mason, OH 45040, U.S.A.  
TEL:1-(888)648-8869 FAX:1-(513)754-0718

**M3 Solution Center-Michigan**

46850 Magellan Drive, Suite 100, Novi, MI 48377, U.S.A.  
TEL:1-(888)648-8869 FAX: 1-(248)926-0928

**M3 Solution Center-California**

16925 E. Gale Avenue, City of Industry, CA 91745, U.S.A.  
TEL:1-(888)648-8869 FAX:1-(626)369-3352

**M3 Solution Center-North Carolina**

11515 Vanstory Drive, Suite 140, Huntersville, NC 28078, U.S.A.  
TEL:1-(888)648-8869 FAX:1-(704)875-9273

**M3 Solution Center-Alabama**

2100 Riverchase Center, Suite 106, Hoover, AL 35244, U.S.A.  
TEL:1-(888)648-8869 FAX:1-(205)988-3423

**M3 Solution Center-Washington**

1000 SW 34th Street Suite G, Renton, WA 98057 U.S.A.  
TEL:1-(888)648-8869

**M3 Solution Center-Texas**

4560 Kendrick Plaza Drive, Suite 120, Houston, TX 77032, U.S.A.  
TEL:1-(888)648-8869 FAX:1-(281)227-0937

**M3 Solution Center-Massachusetts**

753 Forest Street, Suite 110, Marlborough, MA 01752, U.S.A.  
TEL:1-(888)648-8869 FAX:1-(508)485-0782

**Mitutoyo America Corporation Calibration Lab**

965 Corporate Boulevard, Aurora, IL 60502, U.S.A.  
TEL:1-(888)648-8869 FAX:1-(630)978-6477

**Micro Encoder, Inc.**

11533 NE 118th Street, Kirkland, WA 98034-7111, U.S.A.  
TEL:1-(425)821-3906 FAX:1-(425)821-3228

**Micro Encoder Los Angeles, Inc.**

16925 E. Gale Avenue, City of Industry, CA 91745-1806 U.S.A.  
TEL: 1-626-961-9661 FAX:1-626-333-8019

**Canada**

**Mitutoyo Canada Inc.**

2121 Meadowvale Blvd., Mississauga, Ont. L5N 5N1., CANADA  
TEL:1-(905)821-1261 FAX:1-(905)821-4968

**Montreal Office**

7075 Place Robert-Joncas Suite 129, Montreal, Quebec H4M 2Z2, CANADA  
TEL:1-(514)337-5994 FAX:1-(514)337-4498

**Brazil**

**Mitutoyo Sul Americana Ltda.**

**Head office / M3 Solution Center / Factory**  
Rodovia Índio Tibiriça 1555, Bairro Raffo, CEP 08655-000 Suzano – SP, Brasil  
TEL:55 (11)4746-5858

**Argentina**

**Mitutoyo Sul Americana Ltda.**

**Argentina Branch / M3 Solution Center**  
Av. B. Mitre 891/899 – C.P. (B1603CQI)  
Vicente López –Pcia. Buenos Aires – Argentina  
TEL:54(11)4730-1433 FAX:54(11)4730-1411

**Sucursal Cordoba / M3 Solution Center**

Av. Amadeo Sabattini, 1296, esq. Madrid B° Crisol Sur – CP 5000, Cordoba, ARGENTINA  
TEL/FAX:54 (351) 456-6251

---

**Mexico****Mitutoyo Mexicana, S.A. de C.V.**

Prolongación Industria Eléctrica No. 15 Parque Industrial Naucalpan

Naucalpan de Juárez, Estado de México C.P. 53370, MÉXICO

TEL: 52 (01-55) 5312-5612

**Monterrey Office / M3 Solution Center Monterrey**

Blv. Interamericana No. 103, Parque Industrial FINSA, C.P. 66636 Apodaca, N.L., MÉXICO

TEL: 52(01-81) 8398-8227/8228/8242/8244

FAX: 52(01-81) 8398-8226

**Tijuana Office / M3 Solution Center Tijuana**

Calle José María Velazco 10501-C, Col. Cd. Industrial Nueva Tijuana, C.P. 22500 Tijuana, B.C., MÉXICO

TEL: 52 (01-664) 647-5024

**Querétaro Office / M3 Solution Center Querétaro**

Av. Cerro Blanco No.500-1, Colonia Centro Sur, Querétaro, Querétaro, C.P. 76090, MÉXICO

TEL: 52 (01-442) 340-8018, 340-8019 and 340-8020

FAX: 52 (01-442) 340-8017

**Mitutoyo Mexicana, S.A. de C.V. Querétaro Calibration Laboratory**

Av. Cerro Blanco 500 30 Centro Sur, Querétaro, Querétaro, C.P. 76090, MÉXICO

TEL: 52 (01-442) 340-8018, 340-8019 and 340-8020

FAX: 52 (01-442) 340-8017

**Aguascalientes Office / M3 Solution Center**

Av. Aguascalientes No. 622, Local 15 Centro Comercial El Cilindro Fracc. Pulgas Pandas Norte, C.P. 20138, Aguascalientes, Ags. MÉXICO

TEL: 52 (01-449) 174-4140 and 174-4143

**Irapuato Office / M3 Solution Center**

Boulevard a Villas de Irapuato No. 1460 L.1 Col. Ejido Irapuato C.P. 36643

Irapuato, Gto., MÉXICO

TEL: 52 (01-462) 144-1200 and 144-1400

---

## Revision Record

Date of publication	Revision status	Details of revision
December 1, 2018	First edition	Publication

# Mitutoyo Corporation

---

20-1, Sakado 1-Chome, Takatsu-ku, Kawasaki-shi, Kanagawa 213-8533, Japan  
Tel: +81 (0)44 813-8230 Fax: +81 (0)44 813-8231  
Home page: <http://www.mitutoyo.co.jp/global.html>

For the EU Directive, Authorized representative and importer in the EU:  
Mitutoyo Europe GmbH  
Borsigstrasse 8-10, 41469 Neuss, Germany

Printed in Japan

*No. 99MAF600B*