



## Lexmark CX860 Series

With a print speed of up to 60 pages per minute<sup>4</sup>, enormous toner capacity, maximum monthly duty cycle of up to 350,000 pages, and the lowest cost per page of any Lexmark letter/A4 color device, our full-featured letter/A4 overachiever offers performance comparable to light production digital copiers selling for thousands of dollars more. If you don't need to actually print on 11x17/A3 paper, consider the letter/A4-class MFP that performs like an 11x17/A3 device.

### Speed for productivity

**Class-leading speed:** The CX860 is the fastest letter/A4 format MFP in its class\*, with print speed of up to 60 ppm and a maximum monthly duty cycle of 350,000 pages. (Recommended monthly page volume: 5,000 to 50,000 pages.) Even large color print jobs complete quickly so users are more productive.

**Quick-output specialist:** The CX860 can print one color page as fast as 6.5 seconds. In fact, it can often print short jobs before a user gets up from their chair, and minimizes waiting time for users who initiate printing at the device.

**Power printing:** With a 1.6 GHz quad-core processor and 2 GB of standard memory, the CX860 has a powerful print controller to handle complex color jobs with large, high-resolution photos and graphics spanning many pages. Light production 11x17/A3 digital copiers frequently require



Color



Solutions



Up to 60 ppm



10-inch class touch screen



Finishing option



expensive third-party print controllers to achieve similar processing power. Its exclusive high-performance graphics chip drives real productivity.

**Speedy scanning:** Capture paper-based information quickly into your digital workflow or network applications. The CX860 has a faster scanner than most light production 11x17/A3 digital copiers at up to 120 sides per minute in duplex scan mode and up to 60 pages per minute in simplex scan mode. It uses single-pass duplex scan technology to scan both sides of a page simultaneously. This speed, in combination with the powerful processor ensures that information is available when your users need it, so their processes are not slowed down or interrupted.

**Advanced scanning technology:** Thanks to Lexmark's advanced scanning technology, the CX860 offers:

- ▶ Automatic full-speed deskew to straighten scanned images. This eliminates the need for manual straightening of image files and saves time.

- ▶ Full-speed scanning of mixed originals to scan a stack of different-sized originals without slowing the scan speed.
- ▶ Page-level jam recovery to quickly resume a copy or scan job from where a jam or misfeed occurred.
- ▶ Standard MRC (Mixed Raster Content) image file compression technology to reduce scanned file sizes by approximately 50% with no image quality reduction.

Such advanced scanning technology supports accurate data capture using the included AccuRead Optical Character Recognition (OCR) software.

The optional Perceptive Capture software adds even more functionality to extract scanned information, organize it and share content with the people, business systems and processes that need it most, bringing order to chaos.

And the Lexmark VirtualReScan (VRS) integration option improves scanning productivity and capture efficiency by reducing the time involved in manual document preparation and automatically enhancing the quality of scanned images\*\*.

\*Class is defined as A4 color laser MFPs priced above \$7,000 as of November 2015. Comparison based on manufacturers' web price and published speed specifications as reported by Buyers Laboratory (BLI), as of November 2015.

\*\*VirtualRescan integration via Lexmark TotalAgility

## Solutions to solve business problems

Lexmark's Embedded Solutions Framework (eSF) and Cloud Solutions Framework (cSF) allow the CX860 to load and run software solutions tailored to your specific need or industry.

Lexmark devices with cSF can run web apps designed for the device, accessed via the cloud or an on-premise server. eSF applications are created by Lexmark, its partners and customers, and loaded directly on the device.

The CX860 Series can also integrate with Lexmark TotalAgility®, the market's first and only unified platform for the development and deployment of smart process applications. TotalAgility provides the essential connection between your systems of engagement and systems of record, making the information-intensive interactions you have with your customers smarter. TotalAgility dramatically transforms the business-critical First Mile™ of information-intensive customer interactions.

Solutions capabilities like that combine with Lexmark fleet management tools and your existing enterprise software and technical infrastructure to form the Lexmark smart MFP ecosystem. Its adaptability future-proofs your investment in Lexmark technology.

## Included eSF solutions

**AccuRead OCR:** Scanning plus optical character recognition turns paper documents into searchable PDFs or Microsoft Office DOCX files to get documents out of a file cabinet and into a searchable database. Eliminate post-scan OCR processing with desktop- or server-based software by processing data directly at the device.

**Scan Center:** Scan a paper document once and route the digital image file to multiple destinations simultaneously: email addresses, network folders, FTP sites, fax machines, electronic document archives or other secure network locations, plus optional delivery confirmation.

**Forms and Favorites:** Eliminate waste and inaccuracy associated with preprinted forms and other documents by locating and selecting forms from network storage locations or content management applications right from the CX860's touch screen. With the Forms and Favorites solution, you can print Microsoft® Office documents directly from the device, as well as PDF, XPS, JPG, PRN, TIFF and other file formats—useful when you're on the road or don't have a typical office computer to print from.

**Card Copy:** Save time and effort in copying identification cards, licenses and insurance cards by automatically scanning, enlarging and printing both sides of a two-sided card onto one side of a sheet of paper.



AccuRead OCR



Scan Center



Forms and Favorites



Card Copy

## Professional color

**Outsourced color quality, in-house:** The CX860 print quality and speed provides a no-compromise alternative to high-priced production print houses and large, high-priced 11x17/A3 copiers that require expensive, third-party document-processing devices.

**Accurate color:** The CX860 provides both PANTONE® calibration and embedded color sample pages to help you nail perfect color at the design stage. Lexmark Color Replacement technology combines spot color replacement and RGB replacement for precision matching of critical colors such as those found in corporate logos. It's color so accurate, you can do everything in-house.

**Ultra-sharp quality:** The CX860 provides Lexmark's ultra-sharp 4800 Color Quality (4800 CQ) at the default 60 ppm print speed.

**Best-in-class scanning:** The CX860 scanner is capable of 1200 dpi optical resolution for crisp, accurate scans<sup>1</sup>. It uses high-quality CCD (Charged Coupled Device) sensors and a sophisticated five-piece optical glass lens to capture very high resolution details along with a widened color space.

A deep field of focus and very low distortion (maintained even at 120 sides per minute) help scans of color-critical documents to maintain both color accuracy and information accuracy, ensuring that whatever data is on the scanned document gets moved into your workflow applications without errors.

## Advanced media handling

**High input capacity:** The CX860 offers advanced media handling capabilities comparable to light production A3 digital copiers. It features a maximum input capacity of up to 4500 sheets—more than any in its class.\* Higher input capacity reduces the chance that paper runs out, holding up print jobs until someone reloads.

**Staple of business:** The CX860 is the only letter/A4 color laser MFP with configuration options that include a compact, in-line staple finisher and a multi-position staple, hole punch finisher. Automatic stapling saves time when producing bound documents by eliminating the need to separate and manually staple groups of pages, while hole-punched documents are ready for binders.

**Media choices:** The CX860 supports a broad media weight range, from 300 gsm—often used for signage and book covers—to tissue-thin paper such as 70 gsm. You can also use vinyl, labels, cardstock, envelopes and banners, with no media thickness worries.

**Flexible ADF scanning:** The automatic document feeder can scan heavy media up to 120 gsm and very light tissue media down to 52 gsm. Scan sizes as small as 3x5-inch index cards and as long as 25 inches, as well as carbon paper and dot matrix media with sprocket holes. The ADF will even feed and scan folded and torn documents.

## Smart MFP ecosystem

Bridge paper and digital—unstructured and structured—information with devices and connections that drive your business forward.

In an ecosystem, things work in concert to ensure efficient processes. In the business environment, people, technology and information also form an ecosystem, where information exists in both structured and unstructured forms. And the center of this ecosystem is the smart MFP, the connection point between digital and printed information

The Lexmark smart MFP ecosystem brings together the hardware, software, tools and services to help drive your business forward.

\*Class is defined as A4 color laser MFPs priced above \$7,000 as of November 2015. Comparison based on manufacturers' web price and published speed specifications as reported by Buyers Laboratory (BLI), as of November 2015.  
<sup>1</sup>1200 dpi scanning requires TWAIN driver

## Toner and long-life components

**Toner for the long haul:** Ultra High Yield replacement toner cartridges produce up to 55,000 black and up to 55,000 color pages. That's 2.5 times more than the nearest letter/A4 competitor and 40% more than many production-level A3 copiers<sup>†</sup>. Reducing the number of times toner runs out keeps the output going strong in high-usage environments.

**Long-life components:** Constantly replacing components creates unnecessary waste and carbon emissions and hurts productivity as the MFP stops and print jobs back up. The CX860's long-life components minimize downtime with imaging components that can last up to 300,000 pages, depending on usage. And with the option to continue printing color pages in black if any of the color cartridges run out, the CX860 lets you choose to keep your print jobs moving.

**Quality in Unison:** Unison™ Toner is the result of advanced toner science—powerful enough to deliver consistently outstanding image quality with rich, vibrant color and precise details, plus long-life system reliability and amazing sustainability. Documents printed with Unison Toner look great from the first page to the last because of its uniquely engineered formulation. Even when the cartridge is low, there's no fading and no need to shake the cartridge, and you won't waste money by replacing a cartridge that still has toner in it.

Unison Toner's unique low-friction qualities increase toner flow and contribute to its ability to transfer efficiently to the page. Unison™ Toner reduces internal wear on long-life components and protects the print system. This delivers long-term reliability and ultimately saves time, money and the environment.

Unison Toner is uniquely tuned to the CX860's print system for optimal performance.

## Security and more

**Advanced security features:** Lexmark CX860 security features encompass device management, hardening and operation.

**Device management:** A combination of administrative access and passwords, HTTPS, SNMPv3, IPsec and 802.1x support lets you remotely monitor, manage, authorize and authenticate who and what gets access to the network.

**Device hardening:** Built-in tools include port filtering and TCP connection filtering which restrict what connections are active from what sources. Encryption and wiping of the hard disk protect sensitive print job data. Digitally signed firmware updates prevent hackers from uploading compromised software to the MFP.

**Device operation:** You get user authentication via PIN, passwords or badge reader, address book lookup via LDAP over SSL (Secure Socket Layer) to provide a secure connection between the MFP and the network, and device operator panel lockouts to protect the device settings.

**Hard disk protection:** The hard disk is protected with 256-bit AES encryption and encryption keys stored in the MFP's memory, not the hard disk. The data is protected even if the hard drive is removed. This level of protection is automatic at power up—users and administrators do not have to do anything.

The CX860 also performs automatic file-based hard disk wiping after every print job, which cannot be disabled. And the process of clearing a device's disk drive and non-volatile memory data when removing it from service or a secure location is simple with a one-step "out of service" wiping command for authorized users.

<sup>†</sup>Based on information reported by Buyers Laboratory (BLI) as of September 2015.

## Take it easy

**10-inch class color touch screen:** The bright touch screen features an ultra-smooth surface and can be activated by almost anything, including pens, fingertips or nails—without pressure or direct skin contact. And support for gestures like swipe to access panels and menus makes operation easy and intuitive. Audible feedback from the screen provides user assurance, while a separate 10-key number pad improves accessibility and enhances convenience.

**Intuitive interface:** The e-Task interface with modern tablet-like capabilities is familiar to users, minimizing the need for training. On-screen features like print preview and late job customization allow users to select specific pages within a document and change print job settings such as staple or duplex at the device.

**Wireless and mobile printing:** Lexmark Print Management is the first AirPrint®-certified enterprise print management solution. Lexmark mobile printing includes support for iOS, Android, and Microsoft® Windows Mobile printing, with optional wireless and NFC direct connectivity from smartphones and tablets. The CX860 is a Mopria®-certified printer and is Google Cloud Print™ Ready.

**Accessibility:** The CX860 includes advanced Section 508 and European Standard EN 301 549 accessibility features for those with varying levels of ability. Features such as an operator panel that tilts from almost horizontal to almost vertical, paper trays that can be closed with less than five pounds of force, standard headphone jack and standard talk-back feature provide a better user experience for all of our customers.

**Direct printing:** Directly print Microsoft Office files, PDFs and other document and image types from flash drives, network servers or online drives.

**Auto size sensing:** The flatbed scanner of the CX860 includes an auto size sensing feature which allows the scanner to detect the dimensions of originals and automatically adjust the scan area. This provides faster scan performance and smaller files sizes.

**Multifeed detection:** The CX860 also includes ultrasonic multifeed detection to provide assurance that your documents will be accurately and dependably scanned for archiving or integration into your digital workflow. If the auto document feeder (ADF) inadvertently feeds two sheets at a time, the MFP detects it and pauses until the user can separate the sheets.



---

## Lexmark Managed Print Services (MPS)

Lexmark Managed Print Services (MPS) takes a holistic approach to improving the enterprise print architecture. Lexmark aligns devices with the business mission and takes care of their day-to-day management with proactive and predictive service to ensure optimal uptime. Once in place, the managed environment becomes a conduit to unify print and digital information for streamlined processes. Customers benefit with fewer devices, fewer pages, lower cost and improved knowledge worker productivity.

### Built for planet earth

**Advanced toner:** Lexmark's exclusive Unison Toner makes energy savings a reality, using less energy than Lexmark's previous toners by printing at a lower temperature. And through LCCP, the Lexmark Cartridge Collection Program, Lexmark offers a free and easy way to return empty cartridges for sustainable recycling or remanufacturing.

**Power saving modes:** Sleep mode power usage of less than 3.5 watts saves money and energy between print jobs. When the device is not in use, it goes to sleep and wakes for incoming print jobs. In addition, it can be powered on or off from its control panel or a user-defined schedule. And low power-mode sensors wake the MFP when paper is placed in the ADF or the scanner lid is opened, while a proximity sensor detects when a user approaches and wakes the MFP.

**Paper and toner savings:** Standard duplex printing prints on both sides of paper by default. Plus, the unique ColorSaver feature prints images at a lighter shade by default, while leaving text dark and readable, saving toner and money.

And the included Eco-Copy solution lets you print copies of scanned items using predefined settings like duplex, pages per sheet and copies per sheet to further save paper.

**Recycled paper compatibility:** To ensure that you can minimize the impact of paper you use, the Lexmark CX860 Series has been fully tested with a range of recycled papers, up to 100% recycled.

**Environmental certifications:** Lexmark products meet globally recognized environmental standards<sup>1</sup>.

- ▶ ENERGY STAR®
- ▶ Blue Angel
- ▶ EPEAT® Gold

### An affordable alternative

	Lexmark CX860	Typical 11x17/A3 light production copier
Print and copy up to 60 ppm	•	•
Scan up to 120 images per minute (duplex)	•	•
Staple/hole punch/booklet finishing	•	•
Support media up to 300 gsm	•	•
Toner capacity up to 55,000 pages (all colors)	•	
Spot color replacement (CMY and RGB) at no extra charge	•	
Warm-up time under 25 seconds	•	
Maximum monthly duty cycle up to 350,000 pages	•	
Less than 510 sq. inch footprint	•	
Maximum power consumption less than 1000 W	•	
Fax included	•	
Affordable hardware price	•	
Affordable simple stapling	•	
Print on 11" x 17" (A3) media		•

### Lexmark Sustainability

For Lexmark, commitment to the environment isn't a marketing tagline, it's a core value backed up by real action and results. We are forward thinking, innovative, and driven to sustain a healthy planet for generations to come. For our customers and partners we bring this passion, our leading technology and a deep understanding of industry-specific business processes to continuously improve their efficiency as well as our own.

For more information on Lexmark's sustainability initiatives, visit [csr.lexmark.com](http://csr.lexmark.com).

<sup>1</sup>ENERGY STAR V2.0 for Imaging Equipment (EU RoHS and Section 4.3.1.1 iof IEEE 1680.2-2

**1. Intuitive color touch screen with next-generation e-Task interface**

The large 10-in. class color touch screen features an ultra-smooth surface and can be activated by almost anything, including pens, fingertips or nails—without pressure or direct skin contact. The modern interface is familiar to users, minimizing the need for training.

**2. Advanced scanner with duplex automatic document feeder (ADF)**

Save time by scanning both sides of your document in one pass with robust color scanning capabilities and an input capacity of up to 150 sheets.

**3. Expandable input**

Print on multiple paper types and boost input capacity to 4,500 sheets.

**4. Finishing options**

Choose from a compact staple finishing option or a multi-position staple, hole punch finisher to further enhance productivity.

**5. Unison Toner print system with long-life supplies**

Unison Toner delivers consistently outstanding image quality plus long-life system reliability and amazing sustainability in an innovative shake-free design. Ultra High Yield replacement toner cartridges produce up to 55,000 black and color pages.

**6. Software solutions**

Combine eSF capabilities with Lexmark fleet management tools, Lexmark TotalAgility applications, and your existing enterprise software and technical infrastructure to form the Lexmark smart MFP ecosystem. Its adaptability future-proofs your investment in Lexmark color laser technology.

**7. Direct printing**

Print Microsoft Office files, PDFs and other document and image types from flash drives, or select and print documents from network servers or online drives.



Product specifications	Lexmark CX860de	Lexmark CX860dte	Lexmark CX860dtfe
<b>Printing</b>			
Display	Lexmark e-Task 10-inch (25 cm) class color touch screen		
Print Speed: Up to <sup>6</sup>	Black: 60 ppm / Color: 60 ppm		
Time to First Page: As fast as	Black: 6.5 seconds / Color: 6.5 seconds		
Print Resolution	Black: 1200 x 1200 dpi, 4800 Color Quality (2400 x 600 dpi) / Color: 1200 x 1200 dpi, 4800 Color Quality (2400 x 600 dpi)		
Memory	Standard: 2048 MB / Maximum: 4096 MB		
Hard Disk	Included in configuration		
Recommended Monthly Page Volume <sup>2</sup>	5000 - 50000 pages		
Maximum Monthly Duty Cycle: Up to <sup>3</sup>	350000 pages per month		
<b>Copying</b>			
Copy Speed: Up to <sup>6</sup>	Black: 60 cpm / Color: 60 cpm		
Time to First Copy: As fast as	Black: 6.0 seconds / Color: 7.0 seconds		
<b>Scanning</b>			
Scanner Type / ADF Scan	Flatbed scanner with ADF / DADF (single pass Duplex)		
A4/Ltr Duplex Scan Speed: Up to	Black: 114 / 120 sides per minute / Color: 114 / 120 sides per minute		
A4/Ltr Simplex Scan Speed: Up to	Black: 57 / 60 sides per minute / Color: 57 / 60 sides per minute		
ADF Paper Input Capacity: Up to	150 pages 20 lb or 75 gsm bond		
<b>Faxing</b>			
Modem Speed	ITU T.30, V.34 Half-Duplex, 33.6 Kbps		
<b>Supplies<sup>7</sup></b>			
Laser Cartridge Yields (up to) <sup>1</sup>	55,000-page Black and Colour (CMYK) Ultra High Yield Cartridges, 22,000-page Colour (CMY) Extra High Yield Cartridges, 33,000-page Black Extra High Yield Cartridge, 17,000-page Colour (CMY) High Yield Cartridges, 8,000-page Black and Colour (CMYK) Cartridges		
Photoconductor Estimated Yield: Up to <sup>5</sup>	175000 pages, based on 3 average letter/A4-size pages per print job and ~ 5% coverage		
Developer Unit(s) Estimated Yield: Up to <sup>5</sup>	300000 pages, based on 3 average letter/A4-size pages per print job and ~ 5% coverage		
Cartridge(s) Shipping with Product <sup>1</sup>	8,000-page Black Return Program Toner Cartridge, 17,000-page Color (CMY) High Yield Return Program Toner Cartridges		
<b>Paper Handling</b>			
Included Paper Handling	550-Sheet Input, 100-Sheet Multipurpose Feeder, Integrated Duplex, 500-Sheet Output Bin	550-Sheet Input, 100-Sheet Multipurpose Feeder, Integrated Duplex, 2 x 550-Sheet Tray, 500-Sheet Output Bin	550-Sheet Input, 100-Sheet Multipurpose Feeder, Integrated Duplex, 2 x 550-Sheet Tray, 500-Sheet Output Bin, Inline Stapler
Optional Paper Handling	550-Sheet Tray, Staple Punch Finisher, Inline Stapler, 2200-Sheet Tray		550-Sheet Tray, 2200-Sheet Tray
Paper Input Capacity: Up to	Standard: 650 pages 20 lb or 75 gsm bond / Maximum: 4500 pages 20 lb or 75 gsm bond	Standard: 1750 pages 20 lb or 75 gsm bond / Maximum: 4500 pages 20 lb or 75 gsm bond	
Paper Output Capacity: Up to	Standard: 500 pages 20 lb or 75 gsm bond / Maximum: 1950 pages 20 lb or 75 gsm bond		Standard: 300 pages 20 lb or 75 gsm bond / Maximum: 300 pages 20 lb or 75 gsm bond
Media Types Supported	Card Stock, Dual Web Labels, Envelopes, Labels, Plain Paper, Polyester Labels, Vinyl Labels, Refer to the Card Stock & Label Guide., Banner Paper		Card Stock, Dual Web Labels, Envelopes, Labels, Plain Paper, Polyester Labels, Vinyl Labels, Refer to the Card Stock & Label Guide.
Media Sizes Supported	10 Envelope, 7 3/4 Envelope, 9 Envelope, A4, A5, B5 Envelope, C4 Envelope, C5 Envelope, DL Envelope, Index Card, Executive, Folio, JIS-B5, Legal, Letter, 4 x 6", Statement, Universal, Oficio, A6		
<b>General Information<sup>4</sup></b>			
Standard Ports	One Internal Card Slot, USB 2.0 Specification Hi-Speed Certified (Type B), Gigabit Ethernet (10/100/1000), Two Rear USB 2.0 Specification Hi-Speed Certified ports (Type A), Two Front USB 2.0 Specification Hi-Speed Certified port (Type A)		
Optional Network Ports	Internal MarkNet N8360 802.11b/g/n Wireless, NFC		
Noise Level: Operating	Print: 56 dBA / Copy: 59 dBA / Scan: 55 dBA		
Specified Operating Environment	Humidity: 15 to 80% Relative Humidity, Temperature: 10 to 32°C (50 to 90°F), Altitude: 0 - 2896 Meters (9,500 Feet)		
Limited Warranty - See Statement of Limited Warranty	1-Year Onsite Service, Next Business Day		
Size (in. - H x W x D) / Weight (lb.)	32 x 22 x 23.15 in. / 183 lb.	45.8 x 22 x 23.15 in. / 288.9 lb.	45.8 x 25.82 x 23.15 in. / 298.9 lb.

<sup>1</sup>Average continuous black or continuous composite CMY declared cartridge yield up to this number of standard pages in accordance with ISO/IEC 19798. <sup>2</sup>"Recommended Monthly Page Volume" is a range of pages that helps customers evaluate Lexmark's product offerings based on the average number of pages customers plan to print on the device each month. Lexmark recommends that the number of pages per month be within the stated range for optimum device performance, based on factors including: supplies replacement intervals, paper loading intervals, speed, and typical customer usage. <sup>3</sup>"Maximum Monthly Duty Cycle" is defined as the maximum number of pages a device could deliver in a month using a multishift operation. This metric provides a comparison of robustness in relation to other Lexmark printers and MFPs. <sup>4</sup>Printers are sold subject to certain license/agreement conditions. See [www.lexmark.com/printerlicense](http://www.lexmark.com/printerlicense) for details. <sup>5</sup>Actual Yield may vary based on other factors such as device speed, paper size and feed orientation, toner coverage, tray source, percentage of black-only printing and average print job complexity. <sup>6</sup>Print and copy speeds measured in accordance with ISO/IEC 24734 and ISO/IEC 24735 respectively (ESAT). For more information see: [www.lexmark.com/ISOspeeds](http://www.lexmark.com/ISOspeeds). <sup>7</sup>Product functions only with replacement cartridges designed for use in a specific geographical region. See [www.lexmark.com/regions](http://www.lexmark.com/regions) for more details.

This is a Class A device according to the FCC Rules and international electromagnetic emissions standards. This device is not intended for use in residential or domestic environments due to potential interference to radio communications.

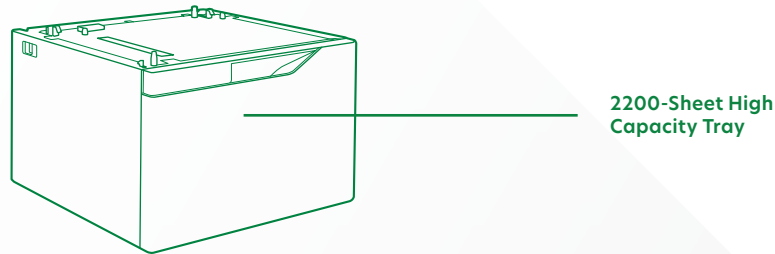
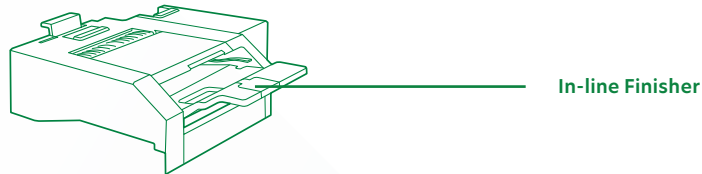
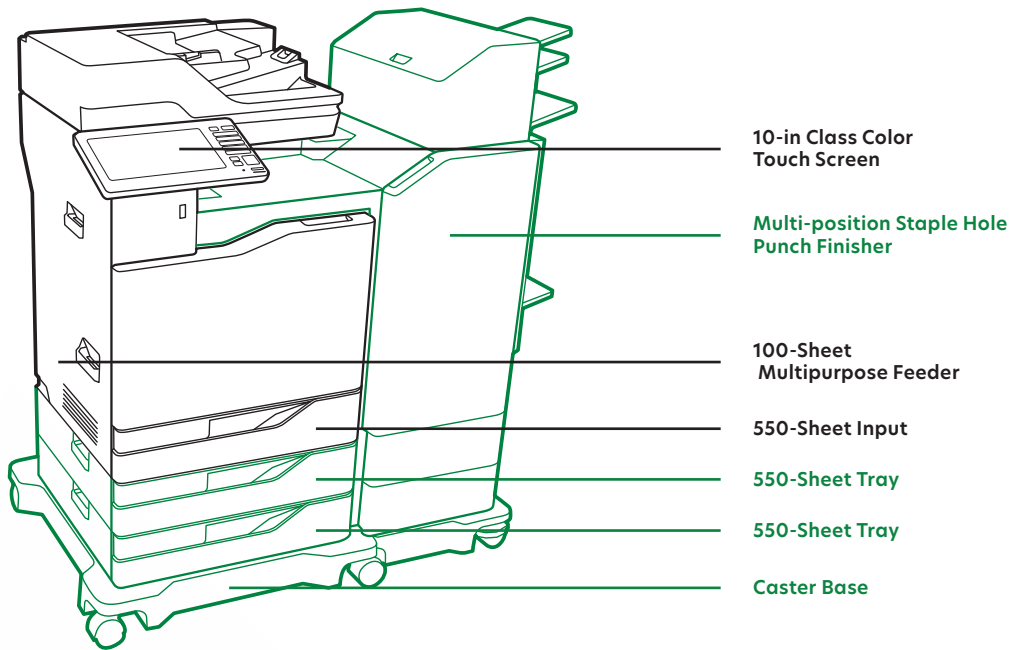

■ Standard  
■ Optional

© 2016 Lexmark and the Lexmark logo are trademarks of Lexmark International, Inc., registered in the United States and/or other countries. All other trademarks are the property of their respective owners.

Unison™ is a U.S. registered trademark.

AirPrint and the AirPrint logo are trademarks of Apple Inc.

ENERGY STAR® is a U.S. registered mark.

EPEAT® is a trademark of EPEAT, Inc. in the United States and other countries.

Google Cloud Print™ is a trademark of Google Inc.

Mopria®, the Mopria® Logo and the Mopria® Alliance logo are registered trademarks and service marks of Mopria Alliance, Inc. in the United States and other countries. Unauthorized use is strictly prohibited.

Notice: "This product includes software developed by the OpenSSL Project for use in the OpenSSL Toolkit (<http://www.openssl.org/>)."