

Lab

Laboport® N96

TRANSLATION OF ORIGINAL  
OPERATING INSTRUCTION  
ENGLISH

EN

# LABOPORT®

## LABORATORY PUMP

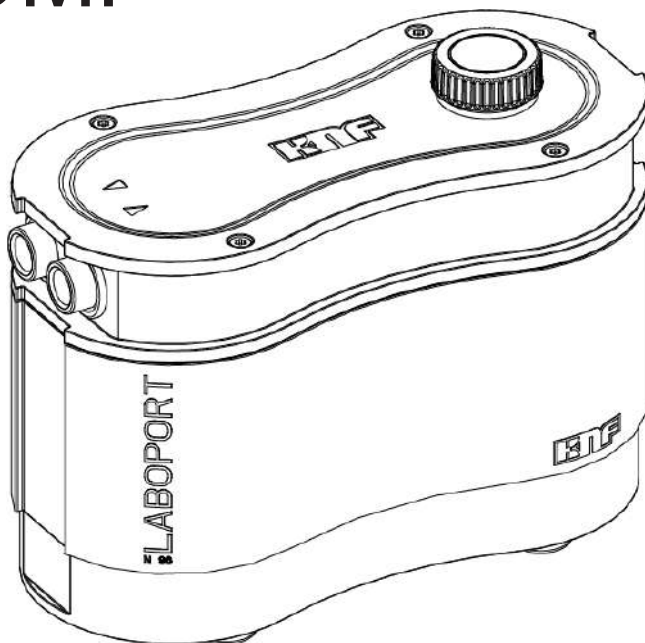

Notice!

Before operating the pump and accessories, read and observe the operating and installation instructions as well as the safety information!

# Index

- 1 Scope of delivery..... 3
- 2 About this document ..... 4
  - 2.1 Using the operating instructions..... 4
  - 2.2 Exclusion of liability..... 4
  - 2.3 Applicable documents..... 5
  - 2.4 Symbols and markings..... 5
- 3 Safety ..... 8
  - 3.1 Personnel and target group ..... 8
  - 3.2 Responsibility of the operator ..... 9
  - 3.3 Working in a safety conscious manner ..... 9
  - 3.4 Operating conditions ..... 10
  - 3.5 Media ..... 10
  - 3.6 Directives and standards ..... 11
  - 3.7 Customer service and repair..... 12
  - 3.8 Disposal ..... 12
- 4 Technical data..... 13
- 5 Product description and function..... 15
- 6 Transport..... 17
  - General ..... 17
- 7 Commissioning..... 19
  - 7.1 Preparing for commissioning ..... 20
  - 7.2 Perform commissioning ..... 20
- 8 Operation ..... 26
  - 8.1 Information on switching the pump on and off ..... 26
- 9 Servicing ..... 27
  - 9.1 Servicing schedule..... 28
  - 9.2 Cleaning..... 28
  - 9.3 Replacing diaphragm and valve plates ..... 29
- 10 Spare parts and accessories..... 38
  - 10.1 Spare parts ..... 38
  - 10.2 Accessories..... 39
- 11 Troubleshooting ..... 40
- 12 Returns..... 43
- 13 Index ..... 44

# 1 Scope of delivery

- Laboport ® N96
- Power supply incl. plug insert (EU, US, UK, AU)
- Hose connector with NPT thread ID6
- Silencer
- Operating instructions
- QuickStart

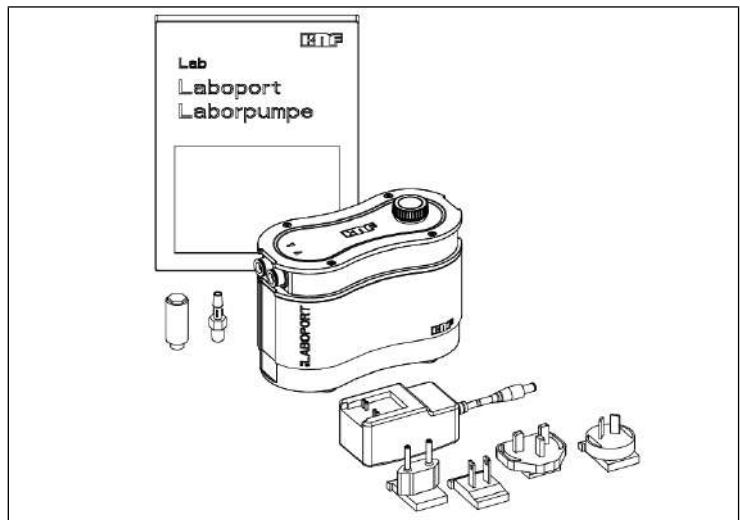

## Unpacking the pump

1. Inspect the pump and the included accessories for transport damage after unpacking.
2. If the packaging is damaged, inform the responsible forwarding agent so that a damage report can be prepared. For further information, read Chapter 6 *Transport* [▶ 17].

## 2 About this document

### 2.1 Using the operating instructions

The operating instructions are part of the pump.

- In the event of uncertainties with regard to the content of the operating instructions, please contact the manufacturer (contact data: see *www.knf.com*). Please have the type and serial number of the pump ready.
- Read the operating instructions before you commission the pump.
- Only pass on the full and unchanged operating instructions to any subsequent owner.
- Keep the operating instructions within reach at all times.

**Project pumps** For customer-specific project pumps (pump models that begin with "PJ" or "PM"), there may be deviations from the operating and installation instructions.

- For project pumps, also observe the agreed specifications.

### 2.2 Exclusion of liability

The manufacturer assumes no liability for damages and malfunctions resulting from failure to observe the operating instructions.

The manufacturer assumes no liability for damages and malfunctions resulting from changes or modifications to the device and improper handling.

The manufacturer assumes no liability for damages and malfunctions resulting from impermissible spare parts and accessories.

## 2.3 Applicable documents

The listed documents must also be observed. The valid versions are available at [www.knf.com/Downloads](http://www.knf.com/Downloads).

- Data sheet
- 3D model

Also to be observed are:

- Local terms and conditions
- Sales documents and agreement between KNF and customer.

## 2.4 Symbols and markings

### Warning notice

---



A notice that warns you of danger is located here.

Possible consequences of a failure to observe the warning notice are specified here. The signal word, e.g., Warning, indicates the danger level.

- Measures for avoiding the danger and its consequences are specified here.
-

## Danger levels

Signal word	Meaning	Consequences if not observed
DANGER	warns of immediate danger	Death or serious injury or serious damage will result.
WARNING	warns of possible danger	Death, serious injury or serious damage is possible.
CAUTION	warns of a possibly dangerous situation	Minor injury or damage is possible.
NOTICE	Warns of possible damage	Damage is possible.

Tab. 1: Danger levels













## Other notices and symbols

→ An activity to be carried out is specified here (a step).

1. The first step of an activity to be carried out is specified here.  
Other sequentially numbered steps follow.

**i** This symbol indicates important information.

### Explanation of pictograms

Pictogram	Meaning
	General warning symbol
	Warning of hot surface
	Warning of electrical voltage
	Warning of poisonous substances
	Warning of hand injuries through crushing
	ESD protected area
	Observe the operating instructions
	General mandatory sign
	Unplug mains plug
	Use foot protection
	Use hand protection
	WEEE Symbol for separate tracking of electrical and electronic devices. The use of this symbol means that this product must be disposed of with normal household waste.
	Recycling

Tab.2: Explanation of pictograms

### 3 Safety

**i** Observe the safety notices in Chapters 7 *Commissioning* [▶ 19] and 8 *Operation* [▶ 26].

#### 3.1 Personnel and target group

**Personnel** Ensure that only personnel who have received the appropriate training and instruction carry out work on the pumps. This applies in particular to commissioning and maintenance work.  
Make sure that the personnel have read and understood the operating instructions, particularly the chapter on safety.

**Target group**

Target group	Definition
User	Laboratory worker
Specialized personnel	Specialized personnel are personnel who - have relevant professional training in the field covered in the particular section of text; - have current knowledge of the field covered in the particular section of text.

Tab.3: Target group

**Who-does-what matrix**

Lifecycle phase	User	Specialized personnel
Transport		X
Setup	X	X
Preparing for commissioning	X	X
Commissioning	X	X
Operation	X	X
Servicing		X
Troubleshooting		X
Disposal		X

Tab.4: Who-does-what matrix



### 3.2 Responsibility of the operator

The pumps are produced in accordance with the generally recognized rules of engineering, as well as the occupational health, safety and accident prevention regulations. Nevertheless, dangers can arise during their use that lead to injuries to the user or third parties or to damage to the pump or other property.

Make sure that no hazardous situation, physical harm or impairment of the pump can occur.

Operating parameter Only operate and install the pump under the operating parameters and operating conditions described in Chapters 3.4 *Operating conditions* [▶ 10] and 4 *Technical data* [▶ 13].

### 3.3 Working in a safety conscious manner

Observe the regulations on accident prevention and safety during all work on the pumps and during operation.

Avoid touching the pump heads and housing parts as the pump gets hot during operation.

Make sure that the pump has been disconnected from the mains and is de-energized while work is carried out on it.

When connecting the pump to the electrical mains, observe the corresponding safety rules.

Do not expose any body parts to the vacuum.

Take precautions to prevent hazards, noise emissions or hot, corrosive, dangerous or environmentally hazardous gases due to gases escaping from open gas connections.

Ensure that EMC-compliant installation of the pump is guaranteed at all times, and that no hazardous situations can arise therefrom.

Avoid the release of hazardous, toxic, explosive, corrosive, harmful or environmentally hazardous gases or vapors, e.g. by using suitable laboratory equipment with fume cupboard and ventilation control.

### 3.4 Operating conditions

Do not use the pumps if they are not in technically perfect working order; pumps must be operated in accordance with their intended use, with attention to safety and hazard considerations, and in conformance with the operating instructions at all times.

The pumps must only be operated in the fully assembled and supplied condition.

Make sure that the installation location is dry and that the pump is protected from rain, splash water, gushing water, dripping water and other contamination.

Check the tightness of the connections between the pipes of the application and the pump (or the connection of the pump) at regular intervals. Leaky connections carry the risk of releasing dangerous gases and vapors from the pump system.

The components that are to be connected to the pumps must be designed according to the pneumatic data of the pumps.

### 3.5 Media

Requirements of pumped media Before pumping any medium, check whether the medium can be pumped without hazard in the specific application case.

Take note of any change in the state of matter (condensation, crystallization).

Before using a medium, check the compatibility of the media-contacting components (see 4 *Technical data* [▶ 13]) with the medium.

Only transfer gases that remain stable under the pressures and temperatures that arise in the pump.

Handling of hazardous media Upon breakage of the diaphragm and/or leaks, the transferred medium mixes with the air in the surroundings and/or in the vacuum system housing. Make sure that a dangerous situation cannot arise as a result.

When pumping hazardous media, follow the safety regulations that govern working with these media.

- Handling of combustible media
- Note that the pump is not designed to be explosion-proof.
- Make certain that the temperature of the medium is always sufficiently below the ignition temperature of the medium so as to prevent ignition or explosion. This also applies for abnormal operating situations.
- Moreover, note that the temperature of the medium rises when the pump compresses the medium.
- Therefore, make certain that the temperature of the medium also remains sufficiently below the ignition temperature of the medium even when it is compressed to the maximum permissible operating pressure of the vacuum system. The maximum permissible operating pressure of the vacuum system is given in Chapter 4 *Technical data* [▶ 13].
- Make certain that the permissible ambient temperature (see 4 *Technical data* [▶ 13]) is not exceeded.
- Take into account any external energy sources (e.g., radiation sources), which might heat the medium further.
- In case of doubt, contact KNF Customer Service.

### 3.6 Directives and standards

EU/EC  
Directives /  
Standards



The pumps conform the following directives/Ordinances:

- 2011/65/EU (RoHS)
- 2014/30/EU (EMC)
- 2006/42/EC (MD)
- UK Regulation S.I. 2008/1597 Supply of Machinery (Safety)
- UK Regulation S.I. 2016/1091 Electromagnetic Compatibility
- UK Regulation S.I. 2012/3032 Restriction of the Use of Certain Hazardous Substances in Electrical and Electronic Equipment

The following harmonized/listed standards are met:

- EN 1012-2
- EN ISO 12100
- EN 61010-1

- EN 61326-1
- EN IEC 63000



The pumps are inspected by TÜV according to:

- UL 61010-1
- CAN/CSA-C22.2 No. 61010-1

Certificate: No. U8 045055 0021 Rev. 00

### 3.7 Customer service and repair

Customer service and repairs

The pumps are maintenance-free. However, KNF recommends that the pumps be checked regularly for noticeable changes in noise and vibration.

Have repairs to the pumps carried out solely by the KNF customer service personnel responsible for such tasks.

Housings with electrically live components may only be opened by specialist personnel.

Use only genuine spare parts from KNF when performing servicing work.

### 3.8 Disposal

Environmental protection  
WEEE

Store the pump and all accessories in accordance with the environmental provisions. Observe the national and international regulations. This applies in particular to parts that are contaminated with toxic substances.



If you no longer need your packaging materials (e.g. for return shipment or other transport of the vacuum system), dispose of them in an environmentally friendly manner.



This product is marked in conformance with the EU directive on the disposal of waste electrical and electronic equipment (WEEE). Old devices must not be disposed of with household waste. Proper disposal and recycling help to protect natural resources and the environment. The end user is responsible for disposing of old devices according to the national and international regulations. Alternatively, KNF products (old devices) may also be returned to KNF for a fee (see chapter Returns).

## 4 Technical data

### Technical data

#### Pump materials

Assembly	Material
Pump head	PPS
Diaphragm	PTFE-coated
Valves	FPM

Tab.5: Pump materials

#### Pneumatic data

Parameter	Value
Max. permissible operating pressure [bar rel*]	2,5
Ultimate vacuum [mbar abs.]	<130
Flow rate at atm. pressure [l/min]**	1,5 -7,0 ± 10%

Tab.6: Pneumatic data

\*Bar rel related to 1013 hPa

\*\*Liters in standard state (1013 hPa, 20°C)

#### Pneumatic connections

Pump type	Value
Laboport N96	NPT 1/8

Tab.7: Pneumatic connections

#### Electrical data

##### Pump

Parameter	Value
Voltage [V]	24 DC
Power P [W]	19
Max. permissible mains voltage fluctuations	± 10%
Current consumption [A]	0,9

Tab.8: Electrical data of pump

**Power supply**

Parameter	Value
Voltage [V]	100-240 AC
Frequency [Hz]	50/60
Current consumption [A]	0.7 A / 100 V AC 0.4 A / 230 V AC

*Tab.9: Electrical data of power supply*

**Weight**

Pump type	Value [kg]
Laboport N96	1,3

*Tab.10: Weight*

**Other parameters**

Parameter	Value
Permissible ambient temperature [°C]	+ 5 to + 40
Permissible media temperature [°C]	+ 5 to + 40
Dimensions [L x H x W] [mm]	156 x 119 x 75
Highest permissible relative air humidity of the environment	80% for temperatures to 31°C, decreasing linearly to 50% at 40°C (non-condensing).
Maximum installation altitude [m above sea level]	2000
Protection class of pump	IP40
Start up against	
- Vacuum [mbar abs.]	<130
- Pressure [bar rel*]	2,5

*Tab.11:*

*\*Bar rel related to 1013 hPa*

## 5 Product description and function

- 1 Outlet
- 2 Inlet
- 3 Rotary/push knob
- 4 Silencer
- 5 Hose connector

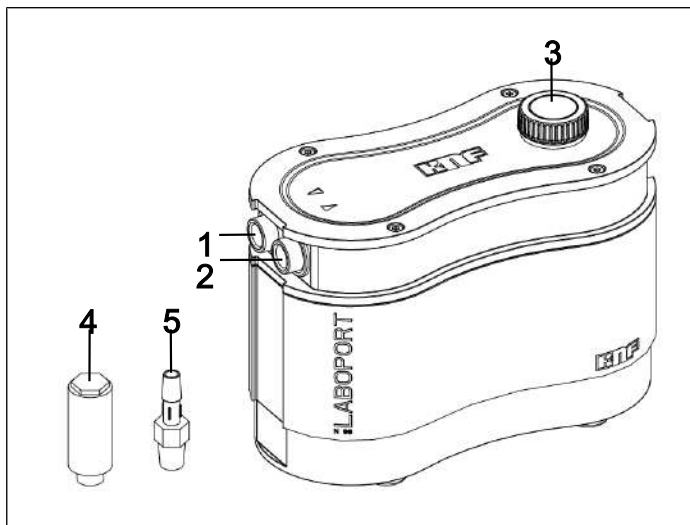

Fig.1: Laboport N96

The pump can be switched on and off with the rotary/push knob(3). This is also used to control the flow rate (see 8.1 *Information on switching the pump on and off* [▶ 26]).

The pump has a vibration-free mount, thereby allowing the inlet (2) and outlet (1) to be easily moved with respect to the remainder of the housing.

## Function of a diaphragm pump

- 1 Outlet valve
- 2 Inlet valve
- 3 Transfer chamber
- 4 Diaphragm
- 5 Eccentric
- 6 Connecting rod

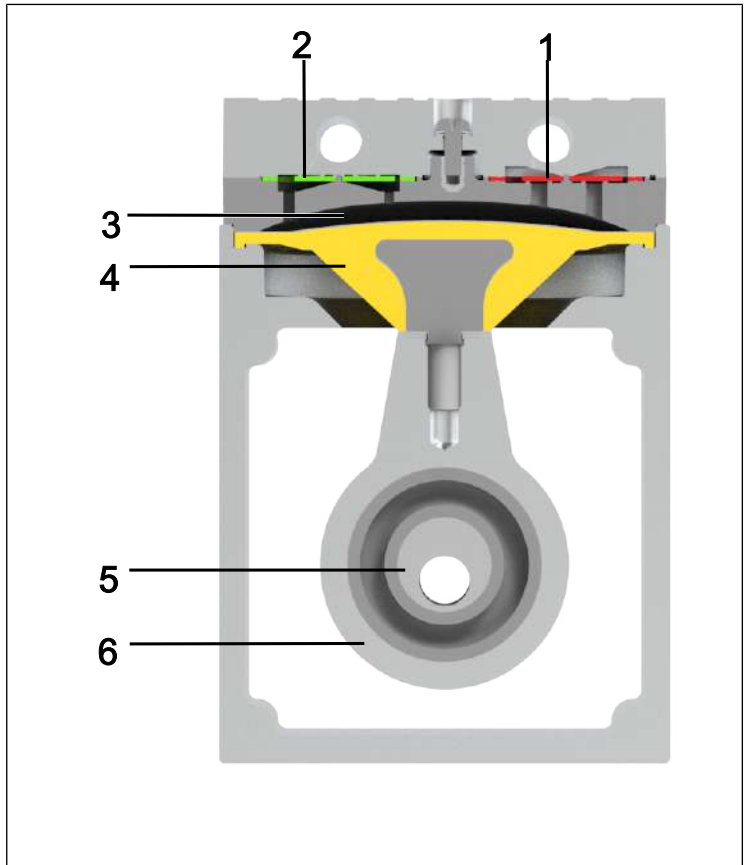

*Fig.2: Function of a diaphragm pump*

Diaphragm pumps transfer, compress (depending on the version) and evacuate gases and vapors.

The elastic diaphragm (4) is moved up and down by the eccentric (5) and the connecting rod (6). In the downwards stroke, it aspirates the gas to be transferred via the inlet valve (2). In the upwards stroke, the diaphragm presses the medium out of the pump head via the outlet valve (1). The transfer chamber (3) is separated from the pump drive by the diaphragm.



## 6 Transport

### General

---



#### CAUTION

Personal injury and/or property damage due to incorrect or improper transport of the pump

In the event of incorrect or improper transport, the pump can fall down, be damaged or injure persons.

- Use suitable auxiliary means if necessary (carrying strap, lifting gear, etc.).
- Where appropriate, wear suitable personal protective equipment (e.g., safety shoes, safety gloves).



#### CAUTION

Risk of injury from sharp edges on the packaging

There is a risk of injury from cutting on the sharp edges when grabbing corners or when opening the packaging.

- Where appropriate, wear suitable personal protective equipment (e.g., safety shoes, safety gloves).

- 
- Transport the pump in the original packaging to the installation location.
  - Store the original packaging of the pump (e.g. for later storage).
  - Inspect the pump for transport damage after receiving it.
  - Document any transport damage in writing.

→ Remove any transport locking devices on the pump prior to commissioning.

### Parameter

Parameter	Value
Storage temperature [°C]	+ 5 to + 40
Transport temperature [°C]	- 10 to + 60
Permissible humidity (non-condensing) [%]	30 to 85

Tab.12: Transport parameter and storage parameter



## NOTICE

Prior to commissioning, make sure that the pump has reached the ambient temperature (4 *Technical data* [▶ 13]).

## 7 Commissioning

Only connect the pump in accordance with the operating parameters and conditions described in Chapter 4 *Technical data* [▶ 13].

- Observe the safety instructions (see Chapter Safety).
- Before connecting, store the pump at the installation location to allow it to reach the room temperature (no condensate may form).

Cooling air supply



**WARNING**

Danger of burning on hot surfaces  
Hot surfaces could occur if the pump overheats.

- When installing the pump, make sure that sufficient cooling air in-feed and discharge is ensured.

Installation location

- Make sure that the installation location is dry and that the pump is protected against rain, splash, gushing, and drip water as well as from other contamination.
- Select a secure location (flat surface) for the pump.
- Protect the pump from dust.
- Protect the pump from vibration, impact and external damage.
- Make sure that it is easy to operate the power switch.

## 7.1 Preparing for commissioning

Before turning on the pump, make sure of the following points:

	Necessary operating requirements
Pump	- Connect all hoses correctly
Pump	- Data of the voltage supply system are consistent with the details on the type plate of the power supply. - Pump outlet not closed or restricted.

Tab.13: Operating requirements for commissioning

## 7.2 Perform commissioning



**CAUTION**

Risk of injury from bursting hoses during pressure applications due to excessively high temperatures

When operating the pump in pressure applications, hoses that are not designed for the head temperatures of the pump at the respective operating point could become porous and burst.

- Use temperature-resistant pressure hoses at the pneumatic connections.
- Wear protective equipment if necessary (e.g., safety gloves, hearing protection).



### Injury to eyes

Coming too close to the inlet/outlet of the pump may result in injury to the eyes due to the present vacuum/operating pressure.

- Do not look into the pump inlet/outlet during operation.

- 
- Only operate the pump in accordance with the operating parameters and operating conditions described in Chapter 4 *Technical data* [▶ 13].
  - Ensure the proper use of the pump (See Chapter Proper use).
  - Eliminate the possibility of improper use of the pump (see Chapter Improper use).
  - Note and follow the safety instructions (see chapter 3 *Safety* [▶ 8]).



Risk of pump head bursting due to excessive pressure increase

- Do not exceed the maximum permissible operating pressure (see 4 *Technical data* [▶ 13]).
- Monitor the pressure during operation.
- If the pressure exceeds the maximum permissible operating pressure of the pump: immediately switch off the pump and remedy the fault (see Chapter *Troubleshooting*).
- Only throttle or regulate the air or gas quantity on the suction line to prevent the maximum permissible operating pressure from being exceeded.
- If the air quantity or gas quantity on the pressure line is throttled or regulated, make sure that the maximum permissible operating pressure at the pump is not exceeded.
- Ensure that the pump outlet is not closed or restricted.



**DANGER**

Risk of dangerous gas mixtures during pump operation

Depending on the medium being transferred, breakage of the media-contacting components can result in a dangerous mixture if the medium mixes with the air in the compressor housing or the surroundings.

- Before using a medium, check the compatibility of the media-contacting components (see 4 *Technical data* [▶ 13]) with the medium.

**i** Excessive pressure, with all of the associated hazards, can be prevented by means of a bypass line with a pressure relief valve between the pressure side and suction side of the pump. Further information is available from KNF Customer Service (contact data: see [www.knf.com](http://www.knf.com)).

Pump standstill → Establish normal atmospheric pressure in the lines while the pump is at a standstill (relieve pump pneumatically).

### Connecting the pump

1. Remove the protective plugs from the pneumatic connections of the pump.
2. Mount suction filter or silencer accessory parts (if present).

Vacuum operation For vacuum operation, connect the hose connector (see Fig. 1/5) to the suction side and the silencer (see Fig. 1/4) or your vacuum system components to the pressure side.

Pressure operation For pressure operation, connect the hose connector to the pressure side and the silencer or your vacuum system components to the suction side.

**NOTICE**

Self-sealing NPT threads are located on the pump. When tightening the accessories, do not tighten them all the way in order to avoid damaging the threads and the pump.

- 
- |                      |                                                                                                                                           |
|----------------------|-------------------------------------------------------------------------------------------------------------------------------------------|
| Connected components | 3. Connect the lines to the pneumatic inlet and outlet.                                                                                   |
| Pump discharge       | 4. Only connect components to the pump that are designed for the pneumatic data of the pump (see Chapter 4 <i>Technical data</i> [▶ 13]). |
|                      | 5. When using as a vacuum pump: Safely drain the pump discharge at the pneumatic outlet of the pump.                                      |
- 

**NOTICE**

Hose radii selected too small can affect the stability of the pump.

**NOTICE**

Secure the pressure-side connections with a fastener (e.g., hose/pipe clamp) to prevent the hoses from slipping down from the connection.

- 
6. Plug the appropriate plug insert into the power supply.
- 

**NOTICE**

Only operate the pump with the supplied SELV power supply.

- 
7. Connect the pump to the power supply.
-



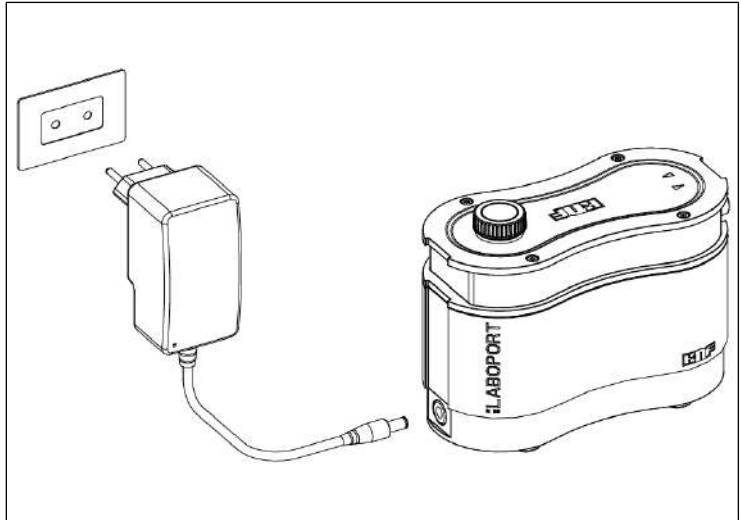

*Fig. 3: Connecting the plug to the pump*

8. Plug the plug of the power supply into a properly installed, grounded socket.

## 8 Operation

### 8.1 Information on switching the pump on and off

#### Switching on the pump

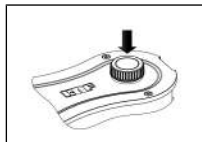

Fig. 4: Switching the pump on/off

- Make certain that the specified pressure or that the specified vacuum (see 4 *Technical data* [▶ 13]) is not exceeded in the lines when switching on.
- Switch on the pump by pushing the rotary/push knob (see Fig. 1/3, see Fig. 4).

#### Set flow rate

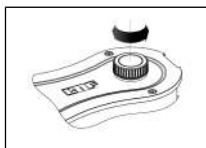

Fig. 5: Set flow rate

You can vary the speed of the pump with the rotary/push knob. This allows you to set the flow rate (see Fig. 5).

- The speed setting of the rotary/push knob is retained when the pump is switched off.

#### Decommissioning/switching the pump off

- When transferring aggressive media, flush the pump before switching off to extend the service life of the diaphragm (see Chapter 9 *Servicing* [▶ 27]).
- Switch the pump with the rotary/push knob (see chapter Fig. 4).
- If possible, establish normal atmospheric pressure (relieve pump pneumatically to extend the service life of the pump).
- Pull the plug of the power supply of the pump from the grounded socket.



**WARNING**

Automatic restart after interruption of the power supply

If the power supply is interrupted, the pump automatically restarts.

- Take appropriate measures if necessary.

## 9 Servicing

---



### ESD-sensitive parts (ESDS)

Failure to observe the ESD protection provision acc. to IEC 61340-5-1 can result in total or partial damage to the pump.

- Maintenance of the pump may only be performed by a qualified person in an ESD-protected area (EPA) acc. to directive IEC 61340-5-1.



### Servicing the pump

Damage to the pumps can result from failure to observe the applicable legal regulations and procedures for the location or intervention by untrained or uninstructed personnel.

- Servicing may only be performed according to the legal regulations (e.g. work safety, environmental protection) and provisions.
- Servicing may only be performed by specialized personnel or trained and instructed personnel.

## 9.1 Servicing schedule

Component	Servicing interval
Pump	<ul style="list-style-type: none"> <li>→ Inspect the pump periodically for external damage or leakage.</li> <li>→ Periodically check for noticeable changes to noises and vibrations.</li> </ul>
Diaphragm and valve plates/seals	<ul style="list-style-type: none"> <li>→ At the latest, replace when the pump flow rate decreases.</li> </ul>

Tab.14: Servicing schedule

## 9.2 Cleaning



### NOTICE

During cleaning work, ensure that no fluids enter the interior of the housing.

### 9.2.1 Flushing the pump

- Before switching off, flush the pump with air at atmospheric conditions (ambient pressure) for about 5 minutes (if necessary for safety reasons: with an inert gas).

### 9.2.2 Cleaning the pump

- Only clean the pump with a damp cloth and non-flammable cleaning agents.
- If compressed air is present, blow out the parts.

### 9.3 Replacing diaphragm and valve plates

- Prerequisites
- Disconnect the pump from mains and ensure that it is voltage-free.
  - Clean the pump and free the pump of hazardous materials.
  - Remove the hoses from the pneumatic pump inlet and pump outlet.
  - If necessary, remove attachment parts such as silencer, suction filter, etc., from the gas connections.

Spare parts/tool

Spare part/tool	Quantity
Spare part set*	1
Torx TX10 screwdriver with torque indicator	1

Tab. 15: Spare parts/tool  
 \*acc. to Chapter 10 Spare parts and accessories [▶ 38]

Information on the procedure Diaphragm and valve plates/seals are the only wear parts in the pumps. They are easy to replace.

Valve plates/seals and diaphragm should generally be replaced at the same time. If the diaphragm is not replaced at the same time as the valve plates/seals, the specified output of the pump can no longer be ensured after the maintenance is performed.

EN



Health hazard due to dangerous substances in the pump

Depending on the medium being transferred, caustic burns or poisoning is possible.

- Wear protective equipment if necessary, e.g., protective gloves, goggles.
- Clean the pump with suitable measures.



Risk of burns from hot pump parts

The pump head or motor may still be hot after operation of the pump.

- Allow the pump to cool after operation.

The diaphragm and valve plates/seals are to be replaced in the following order:

#### a.) Open pump housing

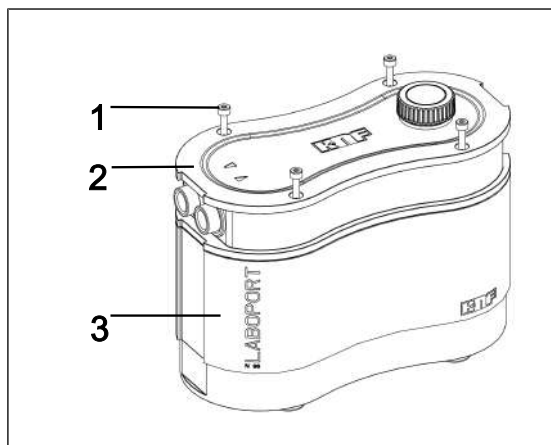

Fig. 6: Opening the housing

1. Loosen the four housing screws (Fig. 6/1) und entnehmen Sie diese aus dem Gehäusedeckel (2) (see Fig. 7). Store the screws for later reassembly.

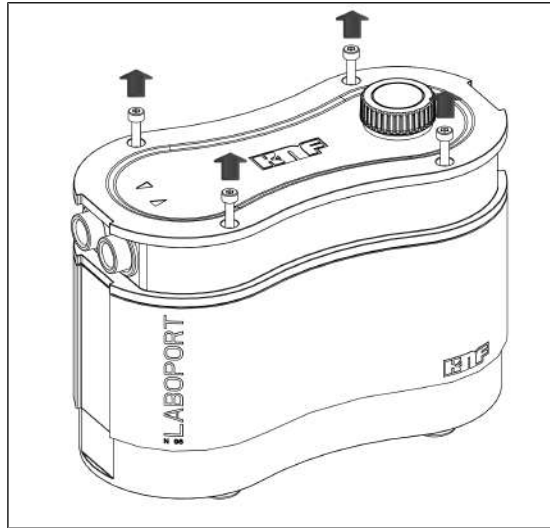

Fig.7: Loosening housing screws



## NOTICE

Make certain that the following steps are performed in an ESD-protected area (EPA).

2. Push the housing cover (2) over the gas connections (see Fig. 8).

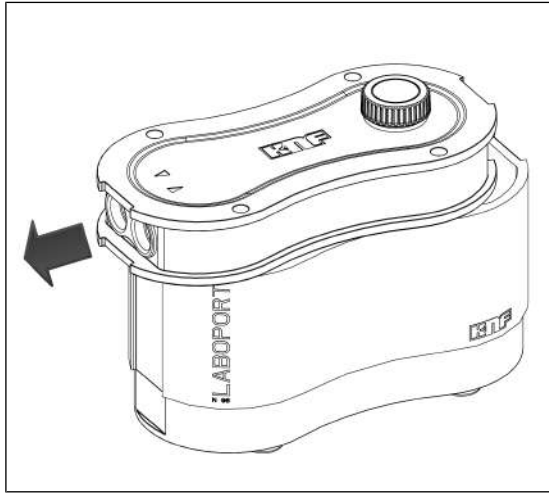

Fig.8: Pushing housing cover over gas connections (open pump)

3. Carefully remove the housing cover (2) and place it next to the pump housing (3) (see Fig. 9).
- i** When removing the housing cover (2), make certain that no larger tensile forces are exerted on the cables and that the cables are not damaged

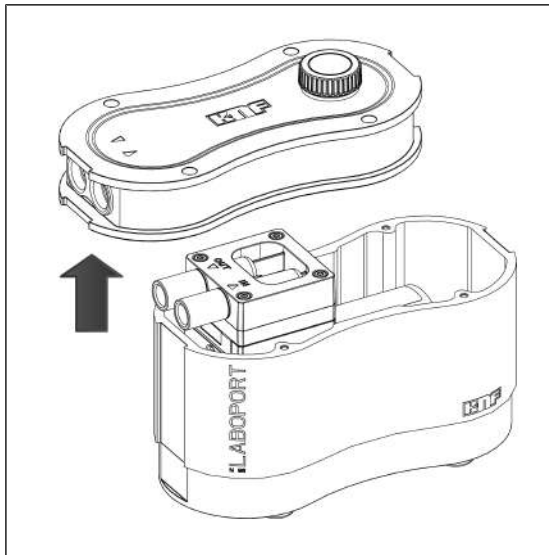

Fig.9: Removing the housing cover



The item numbers within the following work instructions refer to Fig. 10.

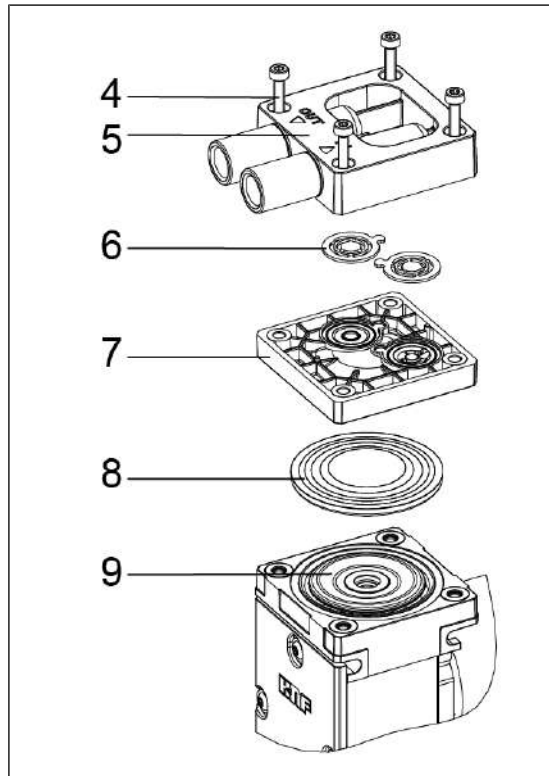

Fig. 10: Exploded view

### b.) Remove pump head

→ Loosen the four head plate screws (4) and remove the head plate (5) together with the intermediate plate (7) from the pump housing.

### c.) Change diaphragm

1. Lift the diaphragm (8) on opposing side edges. Then grasp the diaphragm (8) and move the diaphragm (8) to the upper reversal point. Unscrew the diaphragm (8) counterclockwise.
2. Check all parts for soiling and clean the parts if necessary (for further information, see Chapter 9.2 *Cleaning* [▶ 28]).

3. Screw the new diaphragm (8) onto the connecting rod (9) (clockwise) and hand tighten the diaphragm (8).

**i** When screwing in the diaphragm (8), ensure that it is not overtightened.  
If the diaphragm is overtightened, there is a risk that it could be damaged.

#### **d.) Change valve plates**

1. Separate the head plate (5) from the intermediate plate (7).
2. Remove the valve plates/seals (6) from the head plate (5).
3. Please check the valve seats, intermediate plate (7) and head plate (5) for cleanliness; replace these parts in the event of unevenness, scratches or corrosion (contact your KNF Customer Service in this case).

**i** Insert the new valve plates/seals (6) in the valve seats of the intermediate plate (7); the valve plates/seals (6) for the pressure and suction side are identical; the same applies for the top and bottom of the valve plates/seals (6).

4. By slightly moving the valve plates/seals (6) horizontally, make certain that they are not under tension.
5. Make certain that the valve plates/seals (6) are centered in the valve seats of the intermediate plate (7).
6. Properly dispose of the replaced diaphragm, valve plates/seals.

#### **e.) Mount pump head**

1. Place the intermediate plate (7) with valve plates/seals (6) on the housing.
2. Place head plate (5) on intermediate plate (7) according to the centering.

**i** Place pump head on the compressor housing according to the alignment of the gas connections.

3. Tighten the screws (4) crosswise (tightening torque: 190-200 Ncm).

**f.) Close pump housing**

1. Carefully place the housing cover (Fig. 6/2) on the pump housing (3) (see Fig. 11).
- i** In doing so, make certain that the cables within the pump housing (3) and the circuit board are not damaged.

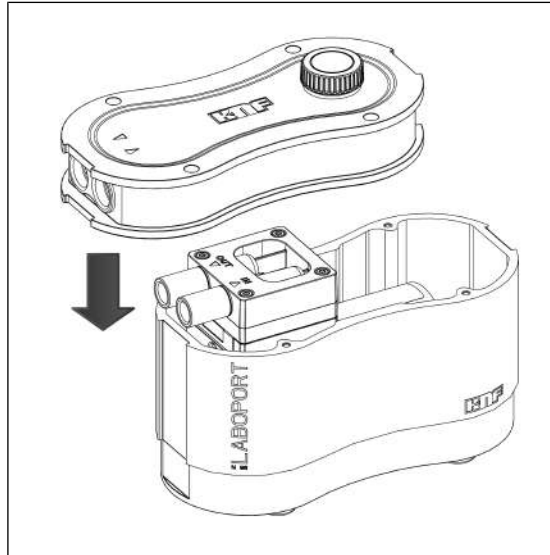

*Fig. 11: Mounting the housing cover*

2. Push the housing cover (2) over the gas connections until the geometry of the housing cover (2) is aligned with that of the pump housing (3) (see Fig. 12).

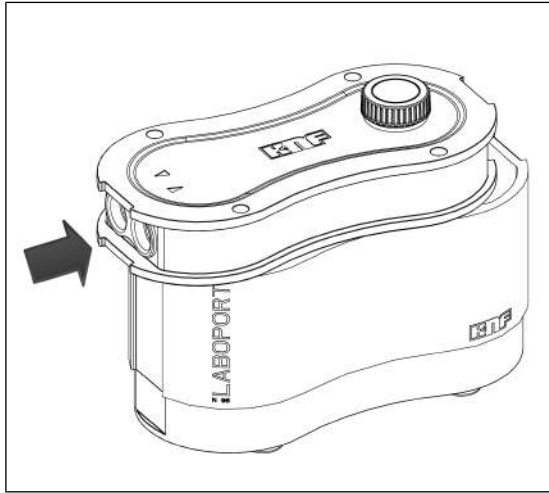

*Fig.12: Pushing housing cover over gas connections (close pump)*

3. Screw in the four housing screws (1) crosswise (tightening torque: 190 – 200 Ncm) (see Fig. 13).

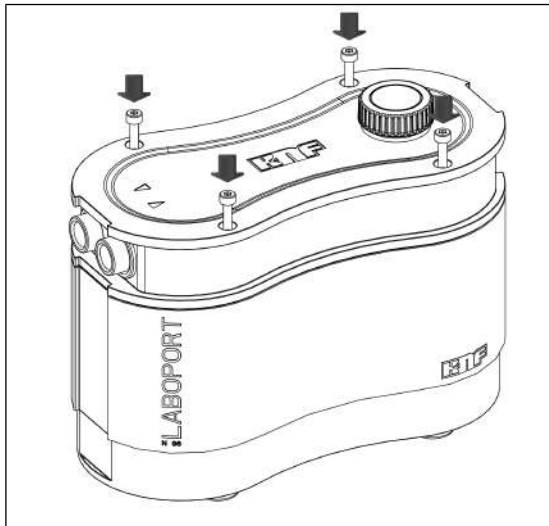

*Fig.13: Screwing in housing screws*

### g.) Final steps

---



## WARNING

Risk of injury and poisoning from leaks

- Before recommissioning the pump, check the pump heads and pneumatic connections for leaks. Leaks may lead to poisoning, chemical burns or similar injuries.

- 
1. If necessary, screw in attachment parts such as silencer, suction filter, etc., from the gas connections.
  2. Perform a function test.
    - Connect the gas connections to the pump.
    - Connect the pump to the power supply.
    - Test the pump for proper function (among other things, ultimate vacuum).
    - Again disconnect the pump electrically and pneumatically.
  3. Install the pump in the desired installation location according to *7 Commissioning [▶ 19]*.
    - Connect the gas connections to the pump.
    - Connect the pump to the power supply.
    - Test the pump for proper function (among other things, ultimate vacuum).

If you have questions with regard to maintenance, please contact your KNF Customer Service (contact data: see [www.knf.com](http://www.knf.com)).

## 10 Spare parts and accessories

**i** To order spare parts and accessories, please contact your KNF sales partner or KNF Customer Service (contact data: see [www.knf.com](http://www.knf.com)).

### 10.1 Spare parts

#### Spare part set

A spare part set consists of:

#### Spare part set

Spare part set	Order number
Laboport N96	322636

*Tab.16: Spare part set*

A spare part set consists of:

Parts	Quantity
Diaphragm	1
Valve plates/ seals	2

*Tab.17: Spare parts*

Other spare parts	Order number
Power supply set	323457
Silencer and hose connector set ID6, PP	323456

*Tab.18: Other spare parts*

## 10.2 Accessories

Accessories	Order number
Tripod holder	323484

Tab.19: Accessories

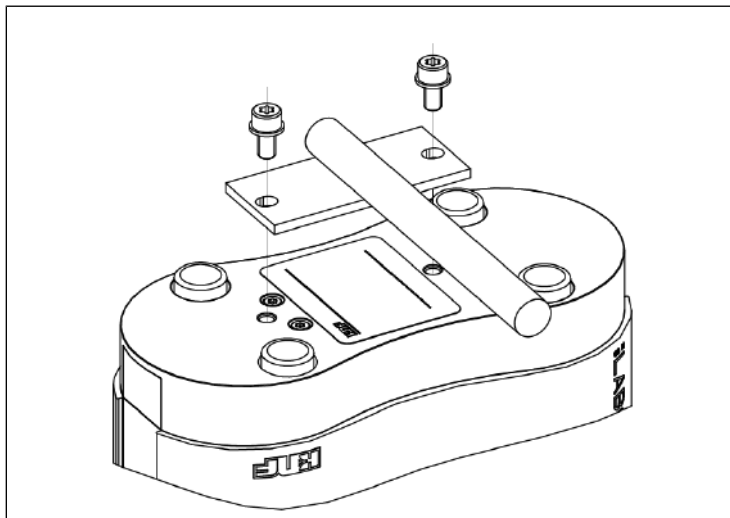

Fig.14: Pump with tripod holder

# 11 Troubleshooting



Danger: electric shock can be life-threatening.

- All work on the pump may only be performed by an authorized specialist.
- Before working on the pump: Disconnect the pump from the power supply.
- Check and ensure that no voltage is present.

→ Check the pump (see following tables).

Pump not delivering	
Cause	Troubleshooting
No voltage in the electrical mains.	→ Check the circuit breaker for the room and switch it on if necessary.
Overtemperature protection of the pump has tripped	→ Disconnect the pump from the electrical mains. → Allow the pump to cool. → Determine the cause of the overheating and rectify.
Connections or lines are blocked.	→ Check the connections and lines. → Remove the blockage.
External valve is closed or filter is clogged.	→ Check external valves and filters.
Condensate has collected in the pump head.	→ Separate the source of the condensate from the pump. → Flush the pump with air at atmospheric pressure for a few minutes (if necessary for safety reasons: with an inert gas).
Diaphragms or valve plates/seals are worn.	→ Replace the diaphragms and the valve plates/seals (see Chapter 9.3 <i>Replacing diaphragm and valve plates</i> [▶ 29]).

Tab.20: Troubleshooting: Pump not delivering



<b>Flow rate, pressure or vacuum too low</b>	
<b>The pump does not reach the output stated in the technical data or data sheet.</b>	
<b>Cause</b>	<b>Fault remedy</b>
Condensate has collected in the pump head.	<ul style="list-style-type: none"> <li>→ Separate the source of the condensate from the pump.</li> <li>→ Flush the pump with air at atmospheric pressure for a few minutes (if necessary for safety reasons: with an inert gas).</li> <li>→ If present, open the gas ballast and flush the pump head.</li> </ul>
There is overpressure on the pressure side and at the same time vacuum or pressure above atmospheric pressure on the suction side.	<ul style="list-style-type: none"> <li>→ Change the pneumatic conditions.</li> </ul>
Pneumatic lines or connection parts have insufficient cross-sections or are throttled.	<ul style="list-style-type: none"> <li>→ Disconnect the pump from the system to determine the output values.</li> <li>→ Eliminate any throttling (e.g. valve) if necessary.</li> <li>→ Use lines or connection parts with a larger cross-section if necessary.</li> </ul>
Leaks occur at connections, lines or pump head.	<ul style="list-style-type: none"> <li>→ Ensure the correct seating of the hoses on the hose connectors.</li> <li>→ Ensure that the connections are correctly mounted.</li> <li>→ Replace the leaky hoses.</li> <li>→ Eliminate the leaks.</li> </ul>
Connections or lines are completely or partially clogged.	<ul style="list-style-type: none"> <li>→ Check the connections and lines.</li> <li>→ Remove any parts or particles that are causing blockages.</li> </ul>
Head parts are soiled.	<ul style="list-style-type: none"> <li>→ Clean the head components.</li> </ul>
Diaphragms or valve plates/seals are worn.	<ul style="list-style-type: none"> <li>→ Replace the diaphragms and the valve plates/seals (see Chapter 9.3 <i>Replacing diaphragm and valve plates</i> [▶ 29]).</li> </ul>

<b>Flow rate, pressure or vacuum too low</b>	
<b>The pump does not reach the output stated in the technical data or data sheet.</b>	
<b>Cause</b>	<b>Fault remedy</b>
Replaced diaphragm and valve plates/seals.	<ul style="list-style-type: none"><li>→ Check the hoses for leaks.</li><li>→ If necessary, carefully tighten the outer screws of the pressure plate crosswise.</li></ul>
Rotary/push knob is not set to max. speed.	<ul style="list-style-type: none"><li>→ Set the rotary/push knob to max. speed.</li></ul>

*Tab.21: Troubleshooting: Flow rate, pressure or vacuum too low*

## 12 Returns

### Preparing for return

1. Flush the pump with air for a few minutes (if necessary for safety reasons: with inert gas) at atmospheric pressure to free the pump head of dangerous or aggressive gases (see Chapter 9.2.1 *Flushing the pump* [▶ 28]).

**i** Please contact your KNF sales partner if the pump cannot be flushed due to damage.

2. Remove the pump.
3. Clean the pump (see Chapter 9.2.2 *Cleaning the pump* [▶ 28]).
4. Send the pump together with the completed Health and Safety Clearance and Decontamination Form to KNF, stating the nature of the transferred medium.
5. Pack the device securely to prevent further damage to the product. If necessary, request original packaging for a fee.

### Returns

KNF shall undertake to repair the pump only under the condition that the customer presents a certificate regarding the medium that is pumped and the cleaning of the pump. Used devices can also be returned under the provisions of the WEEE. Please follow the instructions at [knf.com/repairs here](https://knf.com/repairs).

Contact your KNF sales partner directly if you require additional support for your return service.

## 13 Index

- A**
- Accessories ..... 39
  - Accident prevention ..... 9
- C**
- Cleaning ..... 28
  - Commissioning ..... 21
  - Operating requirements ..... 20
  - Connecting rod ..... 16
  - Connection ..... 9
  - Customer service ..... 12
- D**
- Diaphragm ..... 16, 33
  - Dimensions ..... 14
  - Directives ..... 11
  - Disposal ..... 12
- E**
- Eccentric ..... 16
  - Electrical data ..... 13
  - Environmental protection ..... 12
  - ESD ..... 27
- F**
- Flow rate ..... 13, 26
    - Set flow rate ..... 26
- G**
- Gas connection ..... 13
  - Genuine spare parts ..... 12
- H**
- Head plate ..... 33
  - Head plate screw ..... 33
  - Hose connector ..... 3, 15
  - Housing cover ..... 31
  - Housing screw ..... 31
- I**
- Inlet ..... 15
  - Inlet valve ..... 16
  - Installation altitude ..... 14
  - Installation location ..... 19
  - Intermediate plate ..... 33
- L**
- Laboport ® N96 ..... 3
- M**
- Maintenance ..... 27
  - maintenance-free ..... 12
  - Material ..... 13
  - Medium ..... 10
    - Combustible media ..... 11
    - Hazardous media ..... 10
  - Mounting ..... 19
- O**
- Operating conditions ..... 10
  - Operating pressure ..... 13
  - Ordinances ..... 11
  - Outlet ..... 15
  - Outlet valve ..... 16
- P**
- packaging ..... 3
  - Parameter
    - Operating parameters ..... 9
    - Storage parameter ..... 18
    - Transport parameter ..... 18
  - Parameters

Operating parameters .....	21
Performance, pneumatic .....	13
Personnel .....	8
Pneumatic data .....	13
Power supply .....	3, 25, 26
Connecting power supply .....	24
Plug insert .....	3, 24
Power, electrical .....	13
Pressure application .....	23
Pressure operation .....	23
Protection class of pump .....	14
pump discharge .....	24
Pump housing .....	32
pump standstill .....	23

## R

Repairs .....	12
Replacing wear parts .....	29
Responsibility of the operator .....	9

## S

Scope of delivery .....	3
Servicing .....	12
Silencer .....	3, 15, 23
Spare part .....	38
Spare part set .....	38
Spare parts .....	29
Specialist personnel .....	12
Standards .....	11
Startup parameters .....	14
switching on .....	26

## T

Target group .....	8
Temperature	
Ambient temperature .....	14
Media temperature .....	14
Operating temperature .....	14
Storage temperature .....	18
Transport temperature .....	18
Tools .....	29

Transfer chamber .....	16
Transport .....	17
Tripod holder .....	39
Troubleshooting .....	40

## U

Ultimate vacuum .....	13
-----------------------	----

## V

Vacuum operation .....	23
Valve plate .....	34

## W

Warning notice .....	5
Weight .....	14
Working in a safety conscious manner .....	9





KNF Neuberger GmbH  
Alter Weg 3  
79112 Freiburg  
Germany  
Tel. +49 (0)7664/5909-0

E-mail: [info.de@knf.com](mailto:info.de@knf.com)  
[www.knf.com](http://www.knf.com)

## **KNF worldwide**

You can find our local KNF partners at: [www.knf.com](http://www.knf.com)

