

Operating Instructions
Read and observe this Operating Instructions!

Vacuum pump system

SC 920G

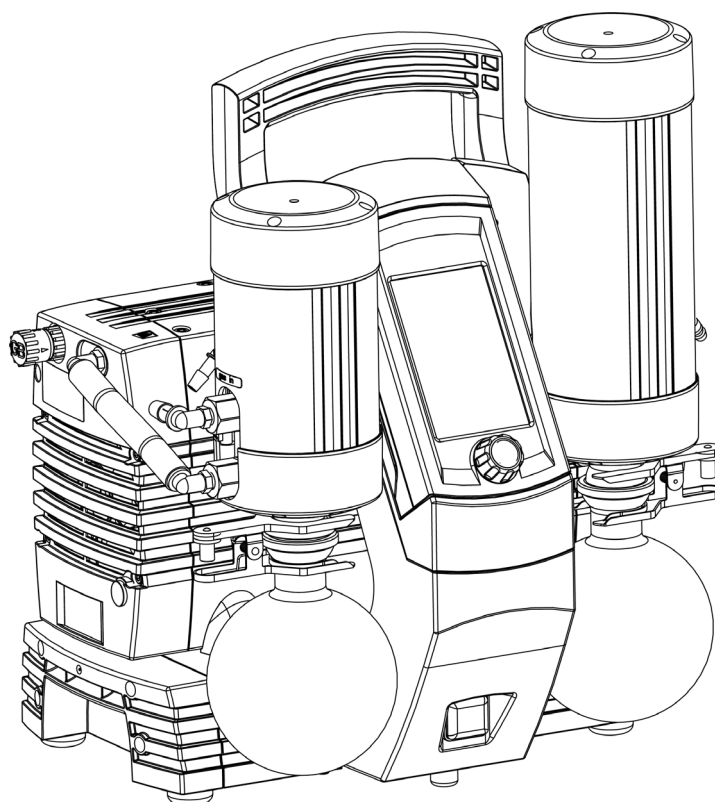

KNF Neuberger GmbH
Alter Weg 3
D-79112 Freiburg
Germany
Phone ++49 / (0)7664 / 5909-0
Fax ++49 / (0)7664 / 5909-99
E-Mail: info@knf.de
www.knf.de

Items including delivery:

- Vacuum pump system
- Coated collection flasks (2 x)
- Flask clamps (2 x)
- Mains cable
- USB cable for connecting vacuum pump system to PC
- Operating Instructions
- Abbreviated instructions

Content	Page
1. About this document	4
1.1. Using the Operating Instructions	4
1.2. Symbols and Markings	4
2. Use	5
2.1. Proper Use	5
2.2. Improper Use	5
3. Safety	6
4. Technical Data	8
4.1. Vacuum pump system	8
4.2. Software	10
5. Design and Function	11
5.1. Vacuum pump system overview	11
5.2. Vacuum pump system functions	13
5.3. Hand terminal	15
5.4. Pump	16
5.5. Gas ballast	16
6. Installation and connection	17
6.1. Installation	17
6.2. Connection	18
7. Operation	19
7.1. Start up	19
7.2. Taking system out of operation	21
8. Operating vacuum pump system	22
8.1. Hand terminal	22
8.1.1. General functions and displays	22
8.1.2. Operation	24
8.2. Software	29
9. Servicing	30
9.1. Servicing Schedule	30
9.2. Cleaning	30
9.2.1. Flushing Vacuum pump system	30
9.2.2. Cleaning Vacuum pump system	30
9.2.3. Emptying collection flask on the suction and pressure sides	30
9.3. Changing Diaphragms and Valve Plates	32
9.4. Replace overpressure valve on high performance condenser	35
10. Troubleshooting	36
11. Ordering Information	40
12. Returns	41

1. About this document

1.1. Using the Operating Instructions

The Operating Instructions are part of the vacuum pump system.

- ➔ Carefully study the Operating Instructions before using a vacuum pump system.
- ➔ Always keep the Operating Instructions handy in the work area.
- ➔ Pass on the Operating Instructions to the next owner.

Project systems

Customer-specific project systems (systems which begin with “PJ” or “PM”) may differ from the Operating Instructions.

- ➔ For project systems, also observe the agreed upon specifications.

i Compliance with the Operating Instructions is essential for the safe and reliable operation of the vacuum pump system. Failure to do so may result in damage or injury.

1.2. Symbols and Markings

Warning



WARNING

A danger warning is located here.

Possible consequences of a failure to observe the warning are specified here. The signal word, e.g. Warning, indicates the danger level.

- ➔ Measures for avoiding the danger and its consequences are specified here.

Danger levels

Signal word	Meaning	Consequences if not observed
DANGER	warns of immediate danger	Death or serious injuries and/or serious damage are the consequence.
WARNING	warns of possible danger	Death or serious injuries and/or serious damage are possible.
CAUTION	warns of a possibly dangerous situation	Minor injuries or damage are possible.

Tab. 1

Other information and symbols

- ➔ An activity to be carried out (a step) is specified here.

1. The first step of an activity to be carried out is specified here. Additional, consecutively numbered steps follow.

i This symbol refers to important information.

2. Use

2.1. Proper Use

The SC 920G vacuum pump system is designed for use in chemical, pharmaceutical, and biological laboratories. The vacuum pump system is exclusively intended for transferring gases and vapors.

Make sure that the installation location is dry and the pump/system is protected against rain, splash, hose and drip water.

Vacuum pump system is solely for use in indoor areas.

Owner's responsibility

Operating parameters and conditions	Only install and operate the vacuum pump system under the operating parameters and conditions described in chapter 4, Technical data.
Requirements for transferred medium	<p>Protect vacuum pump system against humidity.</p> <p>Before using a medium, check the compatibility of the materials of the pump head, diaphragm, valves, sealings and tubing with the medium.</p> <p>Before using a medium, check whether the medium can be transferred danger-free in the specific application case.</p> <p>Only transfer gases which remain stable under the pressures and temperatures occurring in the pump.</p>
High performance condenser	<p>The high performance condenser must be installed on the outlet side of the pump; if it is installed on the inlet side there is a danger of implosion.</p> <p>Observe the correct usage of the gas- and cooling liquid-connections on the high performance condenser. Inlet and outlet connections for the gas are not interchangeable.</p>
Accessories	Laboratory equipment or additional components connected to a vacuum pump system have to be suitable for use with the pneumatic capabilities of the vacuum pump system (see chapter 4, page 8).

2.2. Improper Use

The vacuum pump system may not be operated in an explosive atmosphere.

The vacuum pump system is not suitable for transferring dusts.

The vacuum pump system is not suitable for transferring liquids.

The vacuum pump system must not be used if the entry of air or gas into the vacuum pump system during venting (vent valve) could result in the creation of reactive, explosive or otherwise hazardous mixtures (e.g. with the medium).

The vacuum pump system must not be used to create vacuum and overpressure simultaneously.

An overpressure must not be applied to the suction side of the vacuum pump system.

3. Safety

The vacuum pump system is built according to the generally recognized rules of technology and in accordance with the occupational safety and accident prevention regulations. Nevertheless, dangers can result during their use which lead to injuries to the user or others, or to damage to the vacuum pump system or other property.

Only use the vacuum pump system when it is in a good technical and proper working order, in accordance with its intended use, observing the safety advice within the operating instructions, at all times.

Personnel Make sure that only trained and instructed personnel or specially trained personnel work on the vacuum pump system. This especially applies to assembly, connection and servicing work.

Make sure that the personnel has read and understood the operating instructions, and in particular the "Safety" chapter.

Working in a safety-conscious manner Observe the accident prevention and safety regulations when performing any work on the vacuum pump system and during operation.

Do not expose any part of your body to the vacuum.

Open housing parts with notice sticker (see fig. 1) only after separating mains plug from power source.

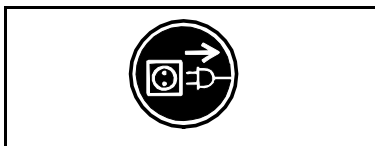

Fig. 1: Notice sticker

Handling dangerous media When transferring dangerous media, observe the safety regulations when handling these media.

Handling flammable media Be aware that the vacuum pump system is not designed to be explosion-proof.

Make sure the temperature of the medium is always sufficiently below the ignition temperature of the medium, to avoid ignition or explosion. This also applies for unusual operational situations.

Note that the temperature of the medium increases when the pump compresses the medium.

Hence, make sure the temperature of the medium is sufficiently below the ignition temperature of the medium, even when it is compressed to the maximum permissible operating pressure of the vacuum pump system. The maximum permissible operating pressure of the vacuum pump system is stated in the technical specifications (see chapter 4, page 8).

If necessary, consider any external sources of energy, such as radiation, that may add heat to the medium.

In case of doubt, consult the KNF customer service.

Ventilating the vacuum pump system When ventilating the vacuum pump system with air or inert gas, be sure to prevent formation of reactive or explosive media. The maximum permissible operating pressure at the ventilation connection (Fig 2/5, page 11) is 0.1 bar g.

Environmental protection	Store all replacement parts in a protected manner and dispose of them properly in accordance with the applicable environmental protection regulations. Observe the respective national and international regulations. This especially applies to parts contaminated with toxic substances.
Standards	<p>The vacuum pump system SC 920G conforms to the Directive 2011/65/EU.</p> <p>The vacuum pump system SC 920G conforms to the safety regulations of the EC Directive 2014/30/EU concerning Electromagnetic Compatibility and the EC Directive 2006/42/EC concerning Machinery. The requirements of the following harmonised standards are fulfilled:</p> <ul style="list-style-type: none">▪ DIN EN 61010-1▪ DIN EN 61326-1 – class A▪ DIN EN 50581 <p>The pumps correspond to DIN EN 60664-1:</p> <ul style="list-style-type: none">▪ the overvoltage category II▪ the pollution degree 2
Customer service and repairs	<p>Only have repairs to the vacuum pump system carried out by the KNF Customer Service responsible.</p> <p>Only authorized personnel should open those parts of the housing that contain live electrical parts.</p> <p>Use only genuine parts from KNF for servicing work.</p>

4. Technical Data

4.1. Vacuum pump system

<i>Materials for parts contacting the medium</i>	
Pump head	PPS
Diaphragms	PTFE-coated
Valves	FFPM
Sealings	FPM
Hose connectors	PVDF
Tubing	Norprene®
Pressure sensor	Ceramics
Venting valve	FFPM
Valve block	PP
Gas ballast valve	PVDF
<i>Pneumatic performance</i>	
Max. permissible operating pressure [bar g]	0
Ultimate vacuum [mbar abs.]	≤ 2 ≤ 5 with open gas ballast
Delivery rate at atm. pressure [l/min]*	0-21 (controllable)
Max. permissible pressure at inert gas connection [bar g]	0.1
<i>Ambient and media temperature</i>	
Permissible ambient temperature	+ 10 °C to + 40 °C
Permissible media temperature	+ 10 °C to + 40 °C
<i>Other parameters</i>	
Vacuum connection and gas outlet	For tube ID 10 mm
Ventilation connection	For tube ID 6 mm
Weight of vacuum pump system [kg]	15.2
Dimensions: width x height x length [mm]	366 x 423 x 294
Maximum permissible ambient relative humidity	80 % for temperatures up to 31°C, decreasing linearly to 50 % at 40°C
Maximum altitude of site [m above sea level]	2000

Tab. 2 (part 1)

*Liters in standard state (1,013 mbar at 0 °C)

<i>Operating parameters of coolant (high performance condenser)</i>	
Max. permissible pressure [bar g]	3
Permissible temperature	- 15 °C to + 20 °C
Coolant connections on high-performance condenser	For tube ID 8 mm
Coolant-wetted surface [cm ²]	Min. 460
<i>Electrical data vacuum pump system</i>	
Voltage** [V]	100-240 +/- 10 %
Frequency [Hz]	50/60
Max. current consumption at 100 V / 115 V / 240 V [A]	1.7 / 1.5 / 0.8
Max. watt consumption [W]	135
Protection class	IP20
Fuse vacuum pump system [A]	2 x T2.5
Drive motor fusing	Electronic overcurrent protection

Tab. 2 (part 2)

** Automatic voltage selection

4.2. Software

The USB connection between the PC and the vacuum pump system is operated as an RS232 interface. Accordingly, in the operating system it is managed as an additional COM connection and can be addressed with conventional terminal software. Please see our website (www.knf.com) for the software and the information on operating the vacuum pump system via software.

5. Design and Function

5.1. Vacuum pump system overview

- 1 Carrying handle
- 2 Hand terminal
- 4 High-performance condenser
- 5 Gas ballast switch
- 6 Ventilation connection
- 7 Vacuum chamber connection (gas inlet)
- 8 Hexagonal gland
- 9 Pump
- 10 Base
- 11 Flask clamp for 12
- 12 Suction-side condensation collection flask (coated)
- 13 Mains switch
- 15 Pressure-side condensation collection flask (coated)
- 16 Flask clamp for 15
- 17 Gas outlet
- 19 Coolant connection on high-performance condenser (feed)
- 20 Coolant connection on high-performance condenser (return)

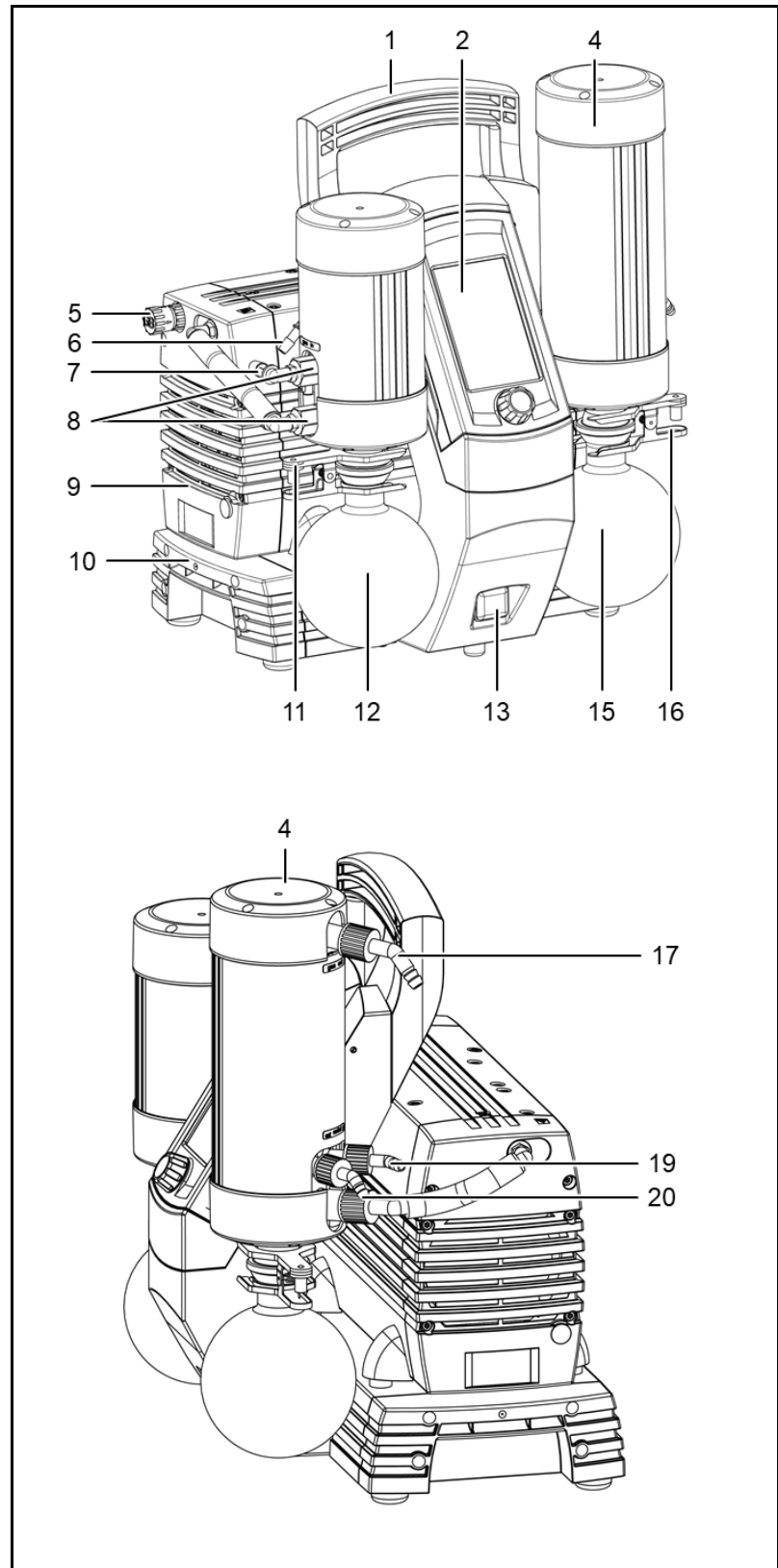

Fig. 2: Vacuum pump system SC 920G

- 1 USB port for connecting vacuum pump system to PC
- 2 Coolant valve connection
- 3 Mains plug connection
- 4 Fuse drawer

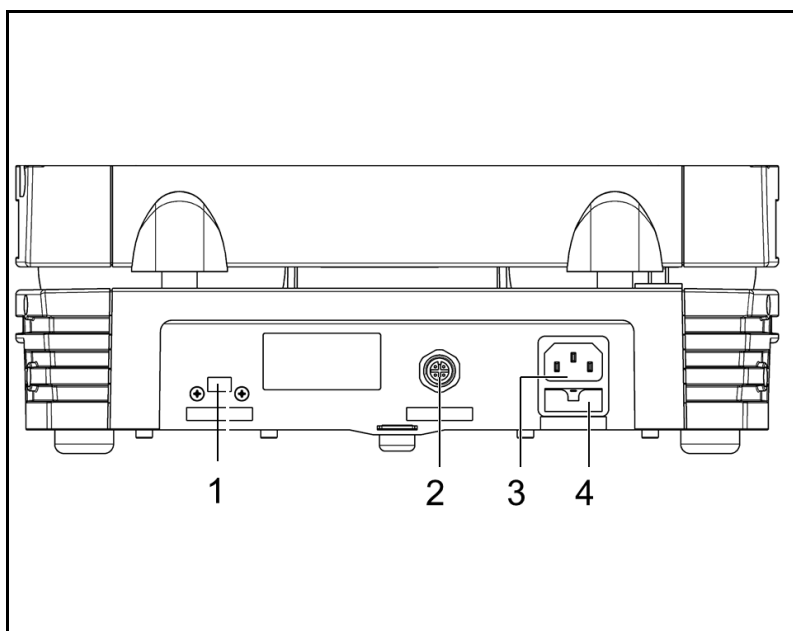

Fig. 3: Plug strip on rear of base (Fig. 2/10)

The vacuum pump system generates a vacuum that can be controlled either through the hand terminal (see chapter 5.3, page 15) or a PC.

Collection flask (Fig. 2/12) collects on the suction side of the pump particles and drops that were, contrary to the requirements of the pump, suctioned from the vacuum chamber. The collection flask is coated (implosion protection) and fastened to the vacuum pump system via a flask clip.

The high-performance condenser at the pump outlet once again recollects solvents from the pumped gas instead of allowing it exit into the environment or fume hood. The high-performance condenser is surrounded by a shell for temperature insulation and explosion protection.

Solvents deposited in the high-performance condenser are collected in the coated (for explosion protection) collection flask (Fig. 2/15). A flask clip secures the glass flask to the condenser flange. A recirculating cooler or continuously flowing cold water cools the high-performance condenser to the condensation temperature.

5.2. Vacuum pump system functions

The vacuum pump system can be operated in four different modes:

- **Evacuate**
The vacuum pump system evacuates a vacuum chamber with adjustable pump capacity.
- **Pressure control**
The vacuum pump system controls system pressure to the set-point pressure value (constant pressure).
- **Automatic**
The vacuum pump system independently finds the sample's vapor pressure and adjusts process pressure accordingly.
- **Function**
The vacuum pump system controls pressure according to the entered pressure curve. Up to 10 different pressure curves can be stored. The following process parameters can be entered:
 - Setpoint pressure at various time points after starting the process
 - Coolant valve (accessory) ON and OFF with time point after start of process
 - Option "Jump" with time after the start of the process:
The system evacuates/ventilates to the required pressure as quickly as possible.
 - Option "Automatic" with time after the start of the process:
Automatic detection of the boiling pressure
If the set limit pressure is reached without a vapor pressure, the program goes to the next function step.
 - Option "Automatic Plus" with time after the start of the process:
Automatic detection of the vapor pressure with subsequent pressure reduction.

At any time during an active process, you can switch to **manual process control**. Functions for Evacuate and Pressure control will be available simultaneously. When activating manual process control, the current actual pressure will be adopted as the first setpoint pressure. In other words, process pressure will be initially "frozen" at the current value.

The operating modes can be **combined in any way** for the purposes of intelligent process control. For example, after successful boiling point detection in the automatic mode, the following operating modes are available for specific distilling off of the solvent recovered:

- Evacuation
(constant vaporization rate for optimum condenser capacity utilization)
- Function
(Following a preset pressure ramp provided in order to attain a separation from components with higher boiling points)

- Manual process control
(active control of the distillation using the setpoint pressure)

In order to change to another operating mode, the process is first stopped and then restarted in the new operating mode.

Gas ballast The gas ballast switch (Fig. 2/5) can be used to open and close the gas ballast valve on the vacuum pump system's pump (see Chapter 5.5).

5.3. Hand terminal

Basic elements

- 2 Touchscreen
- 3 I/O switch
- 5 Rotary/push knob for
 - adjusting pump speed and setpoint pressure
 - switching to manual operation

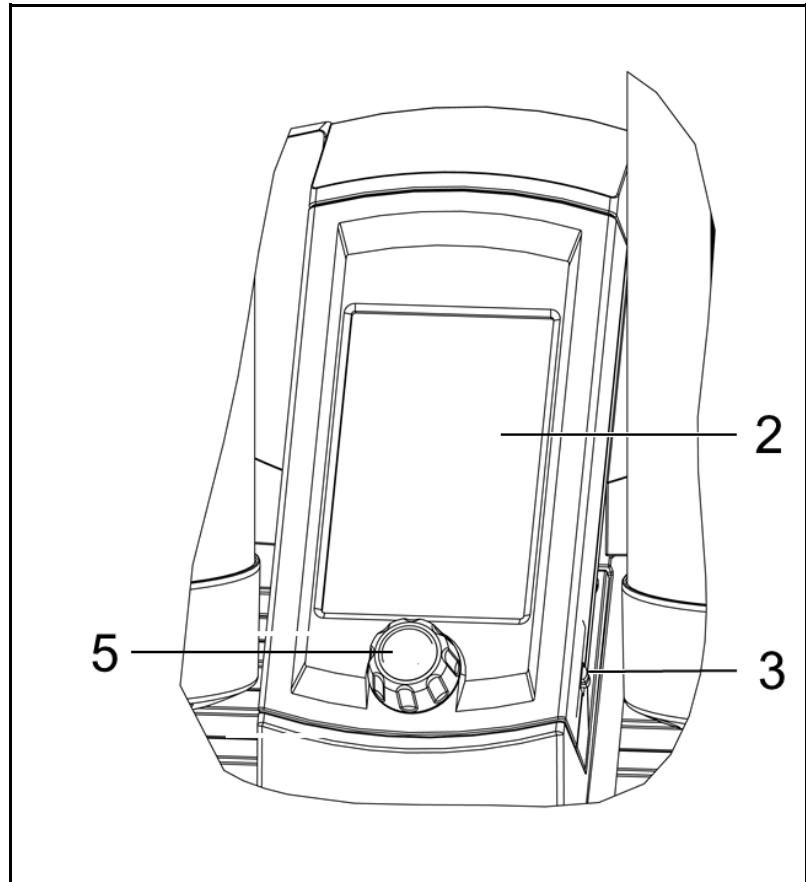

Fig. 4: Hand terminal

Function

The hand terminal is used to set process parameters with which the vacuum pump system will control pressure.

Settings can be made on the hand terminal's touchscreen (2) and with the rotary/push knob (5).

5.4. Pump

Design

- 1 Outlet valve
- 2 Inlet valve
- 3 Transfer chamber
- 4 Diaphragm
- 5 Eccentric
- 6 Connecting rod
- 7 Pump drive

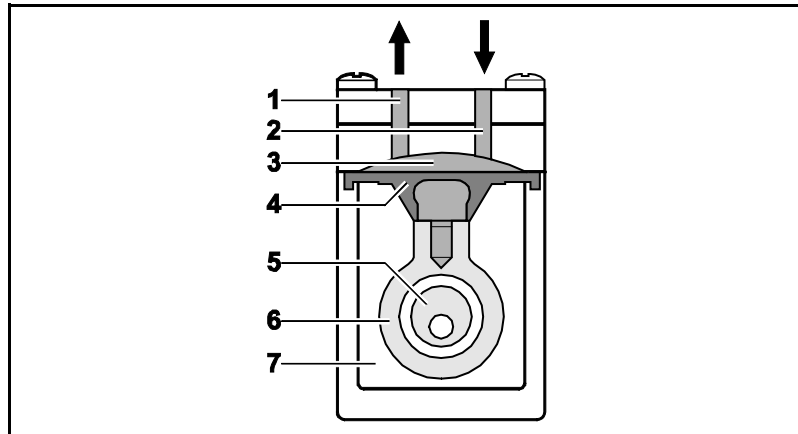

Fig. 5: Pump design

Function Diaphragm pump

Diaphragm pumps transfer, compress (depending on pump version) and evacuate gases and vapors.

The elastic diaphragm (4) is moved up and down by the eccentric (5) and the connecting rod (6). In the downward stroke it aspirates the gas to be transferred via the inlet valve (2). In the upward stroke, the diaphragm presses the medium out of the pump head via the outlet valve (1). The transfer chamber (3) is hermetically separated from the pump drive (7) by the diaphragm.

5.5. Gas ballast

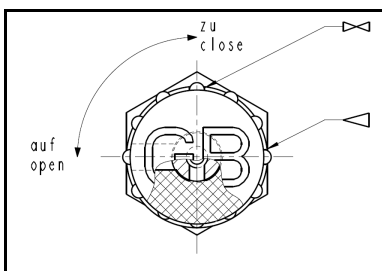

Fig. 6: Gas ballast switch



WARNING

Personal injury caused by poisoning or explosion and damage to the pump

→ Make sure that no reactive or explosive mixtures will be produced when the gas ballast is open.

i When transferring vaporous media, opening the gas ballast valve can minimize the formation of condensation in the pump heads.

i Opening the gas ballast valve deteriorates ultimate vacuum performance.

The gas ballast valve is opened and closed via the gas ballast switch (see Fig. 6).

Please contact KNF Service if you require an inert connection for the gas ballast.

6. Installation and connection

- Only install the vacuum pump system under the operating parameters and conditions described in chapter 4, Technical data, page 8).
- Observe the safety precautions (see chapter 3, page 6).

6.1. Installation

- Before installation, store the vacuum pump system at the installation location to bring it up to room temperature.
- Cooling air supply → Install the vacuum pump system so that the motor fan of the pump can intake sufficient cooling air.
- Installation location → Make sure that the installation location is dry and the vacuum pump system is protected against rain, splash, hose and drip water.
- Choose a safe location (flat surface) for the vacuum pump system.
- Protect the vacuum pump system from dust.
- Protect the vacuum pump system from vibrations and jolts.
- Connected components → Only connect components to the vacuum pump system which are designed for the pneumatic data of the vacuum pump system (see chapter 4, page 8).
- Coolant for high-performance condenser A recirculating cooler or flowing cold water (or another cooling medium) is needed to cool the high-performance condenser to the condensation temperature.

6.2. Connection

1. Connect the vacuum chamber to the gas inlet's hose connector (Fig. 2/7, page 11, for hose inside diameter of 10 mm). For this, vacuum tubing must be used.
2. Connect hose to high-performance condenser in order to discharge gas exhaust (Fig. 2/17, page 11).



Danger of high performance condenser bursting.
The high-performance condenser is not pressure-proof.

CAUTION → Do not reduce or regulate the quantity of gas at the gas outlet, and do not install any components that hinder the gas flow.

- i** Safely discharge gas exhaust so that no gas can escape into the ambient air.
- i** Make sure that the high-performance condenser's gas outlet is not blocked (high-performance condenser is not pressure-proof).
3. Attach coolant feed and return to high-performance condenser (Fig. 2/19 and 20, page 11).
- i** Connect only the KNF coolant valve (see Chapter 11.2, Accessories) to the coolant valve connection (Fig. 3/2, page 12). Consult with KNF before using any other valves.
4. If necessary: Connect inert gas supply to ventilation connection (Fig. 2/6, page 11). Observe the safety instructions in chapter 3.
5. Insert the power cable plug into a properly installed shockproof socket.

7. Operation

7.1. Start up

Before switching on the vacuum pump system, observe the following points:

Operational requirements
<ul style="list-style-type: none"> ▪ All hoses attached properly ▪ Fan openings not blocked ▪ Specifications of the power supply correspond with the data on the vacuum pump system's type plate. ▪ Recirculating cooler or cold water connection ready on high-performance condenser. ▪ The high-performance condenser's gas outlet is not blocked (high-performance condenser is not pressure-proof). ▪ Vacuum pump system is at room temperature. ▪ No reactive, explosive or otherwise hazardous mixtures may be produced when ventilating the vacuum system through the air inlet (Fig. 2/6, page 11) (if necessary, use an inert gas) ▪ When the gas ballast valve is open, no reactive, explosive, or otherwise hazardous mixtures can form (otherwise, contact KNF Service).

Tab. 3

- Only operate the vacuum pump system under the operating parameters and conditions described in chapter 4, Technical data (page 8).
- Make sure the vacuum pump system is used properly (see chapter 2.1, page 5).
- Make sure the vacuum pump system is not used improperly (see chapter 2.2, page 5).
- Observe the safety precautions (see chapter 3, page 6).



WARNING

Personal injury caused by poisoning or explosion and damage to the vacuum pump system.

- Make sure that no reactive or explosive mixtures will be produced when ventilating the vacuum pump system through the air inlet.



WARNING

Hazard of the vacuum pump system bursting due to excessive pressure increase

- Do not exceed max. permissible operating pressure (0 bar).
- Monitor pressure during operation.
- If the pressure exceeds the maximum permissible operating pressure, immediately shut down vacuum pump system and eliminate fault (see chapter 10, page 36).



WARNING

Personal injury caused by poisoning or explosion and damage to the pump.

- Make sure that no reactive or explosive mixtures will be produced when ventilating the vacuum system through the air inlet.
- Make sure that the media are compatible with each other (when running two different processes simultaneously).



CAUTION

Danger of high performance condenser bursting. The high-performance condenser is not pressure-proof.

- Make sure that the high performance condenser's gas outlet is not blocked.

i In order for the high-performance condenser to recover solvent from the delivered gas, it must be cooled by means of a cold water supply or recirculating cooler.

When using a coolant valve:



WARNING

Danger of the high performance condenser bursting

- Make sure that the coolant valve is mounted between the coolant supply and the coolant inlet port of high performance condenser.

Pump standstill

With the pump at a standstill, open pressure and suction lines to normal atmospheric pressure

Inspect and empty collection flasks

At appropriate intervals, inspect the fill level in the condensation collection flasks located on the suction and pressure sides of the vacuum pump system (Fig. 2/12 and 15, page 11). When needed, empty the collection flasks; properly dispose contents.

Switching vacuum pump system on

i The vacuum pump system may not start up against overpressure during switch-on. During operation as well, there may be no overpressure in the pneumatic lines. If a pump starts against pressure, it may block. This activates the thermal switch, and the pump switches off.

- Switch on vacuum pump system at mains switch (Fig. 2/13, page 11).
- Switch on hand terminal at its I/O switch (see Fig. 4/3, page 15).
- i** Refer to chapter 8, page 22, for information on operating the vacuum pump system.

7.2. Taking system out of operation

- Stop the ongoing process.
- When transferring aggressive media, flush the vacuum pump system prior to switch-off to increase the service life of the diaphragms (see chapter 9.2.1, page 30).
- Switch off vacuum pump system with mains switch (see fig. Fig. 2/13, page 11).



WARNING

Uncontrolled operation may result in personal injury and damage to the vacuum pump system.

If the hand terminal is switched off while the vacuum pump system remains switched on, the vacuum pump system will continue to operate with the current settings.

- Always switch the vacuum pump system off when done working.
-

8. Operating vacuum pump system

8.1. Hand terminal

8.1.1. General functions and displays

- 2 Touchscreen
- 3 I/O switch
- 5 Rotary/push knob for
 - adjusting pump speed and setpoint pressure
 - switching to manual operation

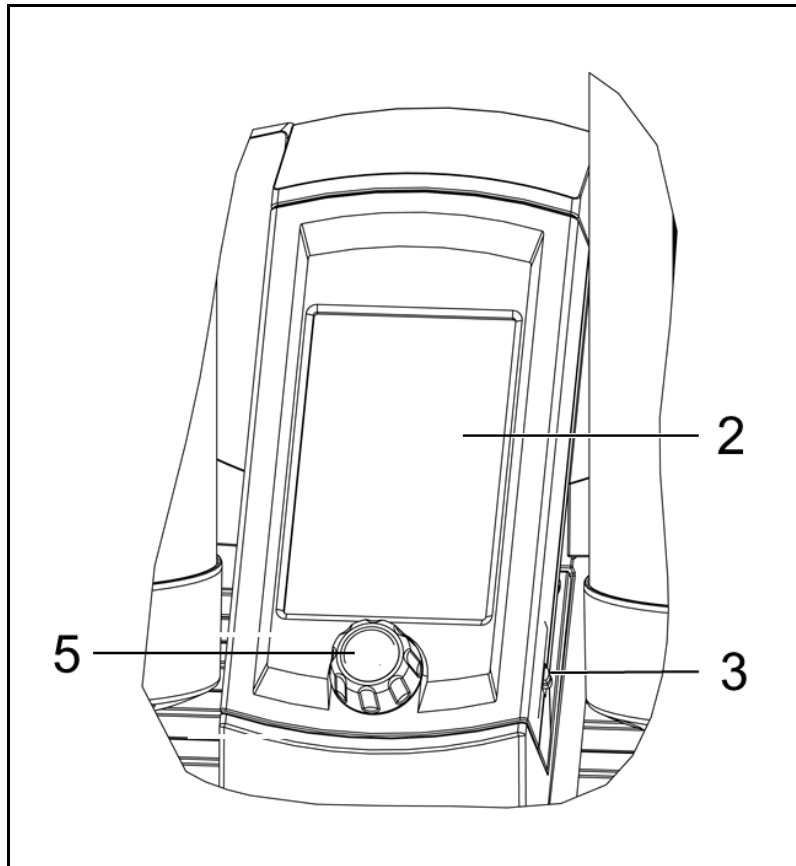

Fig. 7: Hand terminal

The vacuum pump system is operated via the hand terminal with the aid of:

- a rotary/push knob
- a touchscreen.

The **rotary/push knob** has the following functions:

- Rotate: Changes pump capacity or the selected pressure setting (depending on selected operating mode).
- Press: Interrupts the active process and switches into manual process control (pressing effects an evacuation in this case).

Touchscreen contents:

- Display of the most important process variables (Fig. 8, page 24).
- Menu for selecting operating mode and units for pressure display (Fig. 9, page 24).
- Operating buttons (Fig. 9, page 24) with the following functions:
 - Start and stop the process;

- open and close the ventilation valve;
- open and close the high-performance condenser's coolant valve (accessory).

Displays

- 1 Battery:
 - No battery present
- 2 Direct connection to vacuum pump system
- 3 Process time
- 4 Actual pressure in selected pressure unit
- 5 Process active
- 6 Capacity in percent or setpoint pressure in selected pressure unit (depending on operating mode)
- 7 Explanation of rotary/push knob functions (Rotate: change capacity; Press: interrupt operating mode and switch to manual process control)
- 8 Only in *Automatic* operating mode
Automatic with pressure reduction
- 9 Only in *Automatic* operating mode
Automatic pressure reduction active

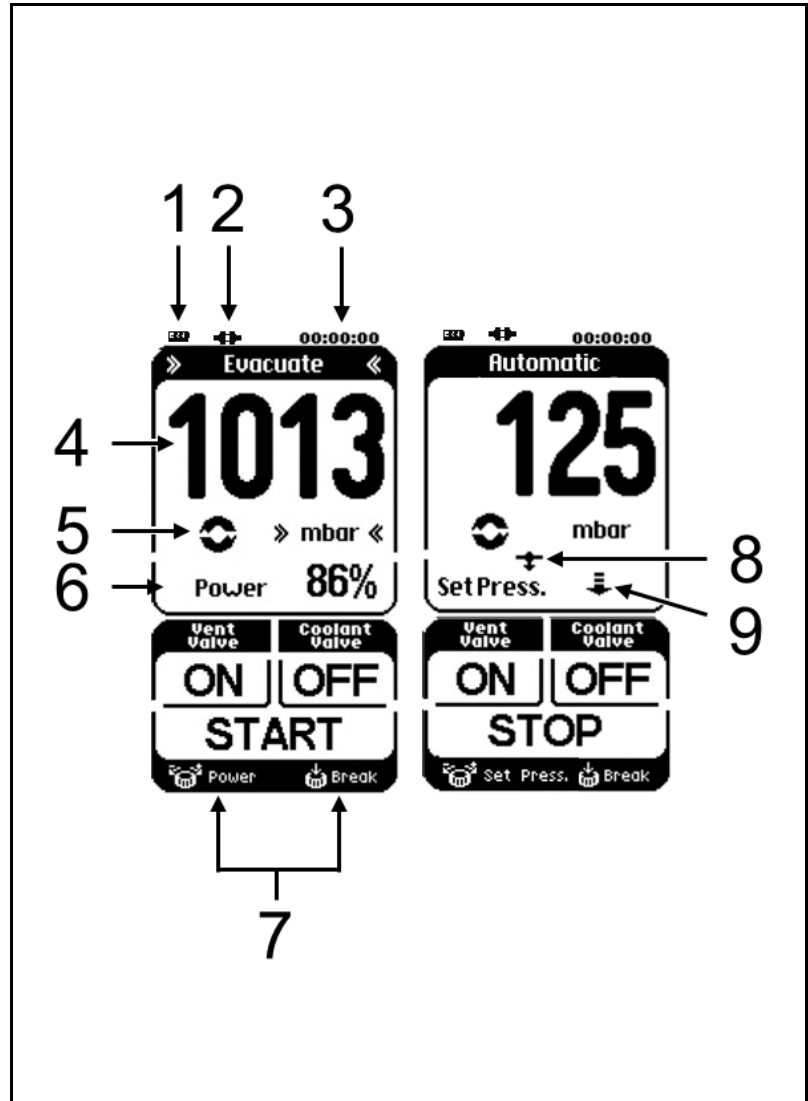

Fig. 8: Display on the touchscreen

Menus and buttons

- 1 Operating mode menu
- 2 Pressure units menu
- 4 Button for ventilation valve:
ON = To open
CLOSE = To close
- 5 Button for coolant valve
(accessory) at high-
performance condenser:
ON = To open
CLOSE = To close
- 6 Button for the process:
START = To start
STOP = To stop
- 7 Button for automatic
pressure reduction:
Press = Finish (the current
pressure is applied as the
setpoint pressure)

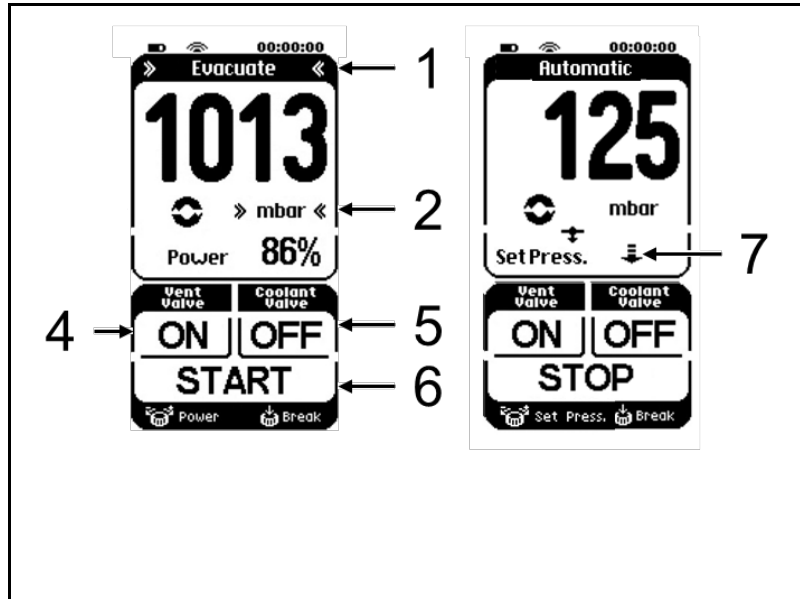

Fig. 9: Menus and buttons on the touchscreen

Operation

Menu language

When the start page appears after switching the hand terminal on, choose between the following languages: German, English, French, Italian, Spanish, Dutch, Japanese, and Chinese. The selection can be made only immediately after switching on.

Pressure unit

Process pressure can be displayed on the hand terminal in mbar, bar, hPa, or Torr.

Use the Pressure units menu to select the pressure units (button on touchscreen; see Fig. 10).

- i** Pressure units can be changed only when no process is active.
- i** In order to change the unit of pressure, it is necessary to temporarily switch to another operating mode.

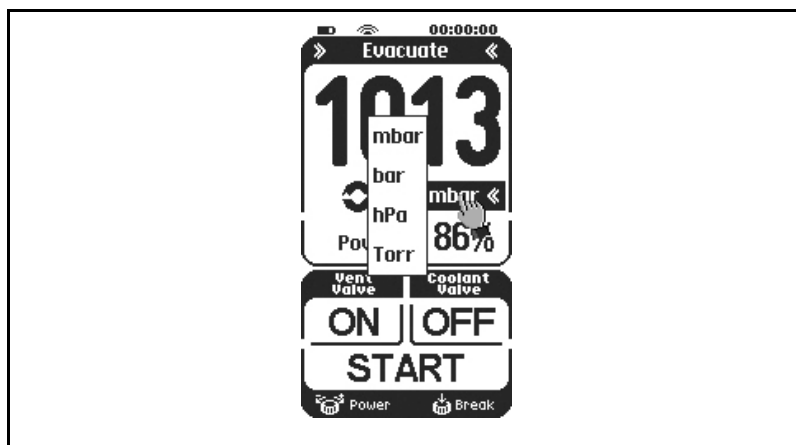

Fig. 10: Pressure units menu

Operating modes

The current operating mode is displayed at the top of the hand terminal's touchscreen. Press on this line of the touchscreen to open the menu for changing operating mode (see Fig. 11, at the top).

i Operating mode can be changed only when no process is active.

Switching to manual process control (Break)

- Press briefly on the rotary/push knob:
Manual process control; actual pressure will be adopted as the setpoint pressure and actively controlled.

Within the manual process control

- Press on the rotary/push knob:
Vacuum pump system will evacuate.
- Let go:
Actual pressure will be adopted as setpoint pressure.
- Rotate:
Changes setpoint pressure.

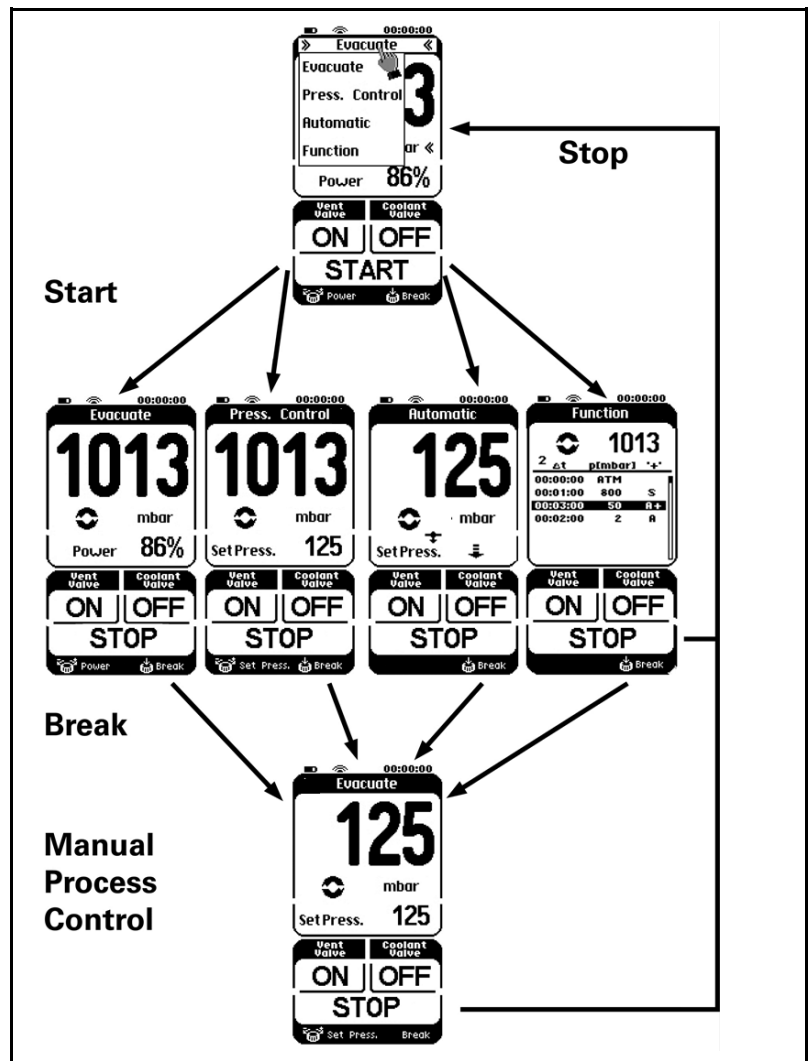

Fig. 11: Operating mode menu

Starting and stopping the process

Pressing the START button starts a process.

Pressing the STOP button stops a process.

Open and close the ventilation valve



WARNING

Personal injury caused by poisoning or explosion and damage to the vacuum pump system

→ Ensure that the creation of reactive, explosive or otherwise hazardous mixtures during the supply of air is prevented.

Pressing the ON button for ventilation valve (left button below) opens the ventilation valve.

i If the ON button is pressed for more than 3 seconds, the ventilation valve remains open.

If the ventilation valve is permanently open (OFF button shown in display), it can be closed again with the *OFF* button.

Opening and closing coolant valve (accessory)

Pressing the ON button for coolant valve (right button below) opens the coolant valve on the high-performance condenser.

Pressing the OFF button for the coolant valve closes the coolant valve on the high-performance condenser.

Entering value in Evacuate operating mode

Use the rotary/push knob to set pump capacity.

Entering value in Pressure control operating mode

Use rotary/push knob to set desired pressure.

Entering value in Automatic operating mode

Not necessary to enter value.

If a boiling point is detected in *Automatic* mode, after the system regulates to this pressure, the pressure is reduced automatically to speed up evaporation of the solvent (see Fig. 12).

- 1.) Start Automatic operating mode
- 2.) Boiling point detected; system regulates to this pressure
- 3.) Automatic pressure reduction

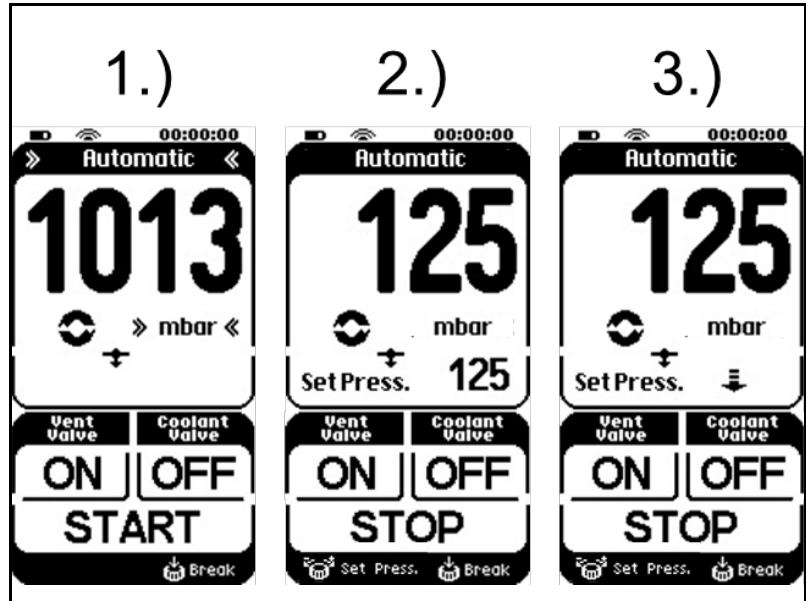

Fig. 12: Automatic function sequence

i If you press the arrow key (see Fig. 9/7) during automatic pressure reduction, the current pressure is applied as the new setpoint pressure and the vacuum pump system regulates to this pressure. The current setpoint pressure is shown in the display in place of the arrow.

If you press again on the setpoint pressure value, automatic pressure reduction is reactivated and the arrow appears in the display after about 25 seconds.

Entering value in Function operating mode

The desired pressure curve is entered via data points that connect the vacuum pump system to pressure ramps.

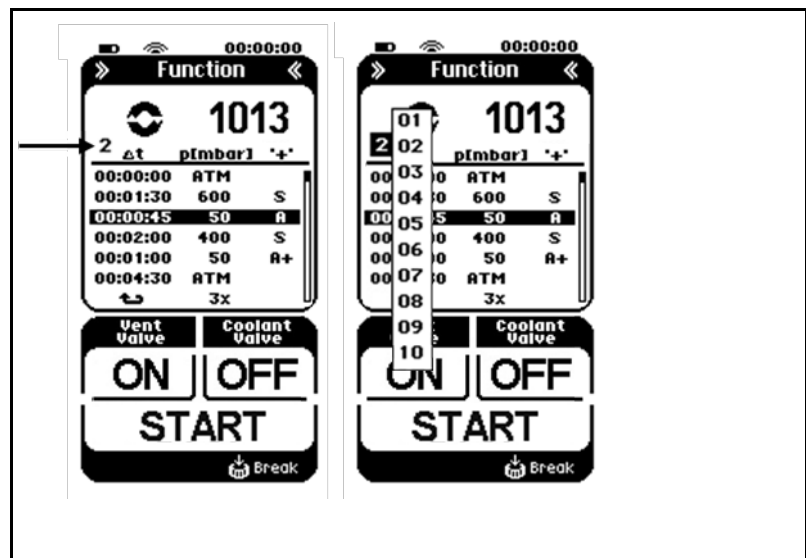

Fig. 13: Menu for Function operating mode

Entering data points (up to 12):

1. Time interval since the last data point: Δt

2. Setpoint pressure: p (mbar) / p (bar) / p (hPa) / p (Torr)
3. Additional options ("+" column) to influence the course of the function:
 - CV1: Open coolant valve (accessory):
 - CV0: Close coolant valve (accessory):
 - S: Jump – the system evacuates/ventilates to the required pressure as quickly as possible.
 - A: Automatic – Automatic detection of the boiling pressure

i If the set limit pressure is reached without a vapor pressure, the program goes to the next function step.

- A+: Automatic Plus – Automatic detection of the vapor pressure with subsequent pressure reduction.

Line selection (see Fig. 13):

- To change the line:
Turn the rotary/push knob.
- To select a line for editing:
Press the rotary/push knob.

To edit a selected line:

- To change columns:
(e.g. from Δt to p (mbar):
Press the rotary/push knob.
- To change an entry:
Turn the rotary/push knob.

i After the last column (+), the display automatically returns to line selection and jumps to the next line.

i If you are in input mode and have not entered any data within 3 seconds, the display automatically returns to line selection.

i The function values of the data point table are stored in the internal memory of the vacuum pump system when the process starts, and are available again when there is a restart.

i Changes to the function values (sampling point table) are carried over directly from the PC software, which may be used simultaneously.

Repeating/deleting sampling points:

The following symbols may be set in the column for the time intervals under the value 00:00:00:

-  = Repetition. The desired number of repetitions can now be specified in the field for the setpoint pressure.
- ... = Deletion of the data point.

In both cases, all subsequent sampling points are automatically deleted.

Calling the stored data point tables:

- Press the button to select data point tables (arrow in Fig. 13) and select the required data point table.
You can now see the data point table that is stored under the number.

i Up to 10 different data point tables can be stored and called as required. The number in the display (arrow in Fig. 13) indicates the data point table that is currently selected.

8.2. Software

i Please see our website (www.knf.com) for the software and the information on operating the vacuum pump system via software.

9. Servicing

9.1. Servicing Schedule

Component	Servicing interval
Vacuum pump system	Regular inspection for external damage or leaks
Diaphragms and valve plates	Replace at the latest, when pump output decreases

Tab. 4

9.2. Cleaning

i When cleaning, make sure that no liquids enter the inside of the housing.

9.2.1. Flushing Vacuum pump system



WARNING

Personal injury caused by poisoning or explosion and damage to the vacuum system

→ When flushing the vacuum pump system with inert gas, make sure that the gas ballast valve is closed so no reactive or explosive mixtures can form.

Before switching off the vacuum pump system, separate it from the vacuum chamber and flush it with air (if necessary for safety reasons: with an inert gas) under atmospheric conditions (ambient pressure) for about five minutes.

If inert gas is used: connect the inert gas feed to the gas inlet (Fig. 2/7, page 11) of the vacuum pump system. Observe the safety instructions in chapter 3.

9.2.2. Cleaning Vacuum pump system

→ Only clean vacuum pump system with a damp cloth and non-flammable cleaning agents.

9.2.3. Emptying collection flask on the suction and pressure sides

Suction side

1. Grasp the collection flask (Fig. 2/12, page 11) and simultaneously remove attachment clamp **11**; pull out collection flask.
2. Dispose of contents in collection flask according to local regulations. Then rinse out collection flask.
3. Reattach collection flask.

Pressure side

1. Grasp the collection flask (Fig. 2/15, page 11) and simultaneously remove attachment clamp **16**; pull out collection flask.
2. Dispose of contents in collection flask according to local regulations. Then rinse out collection flask.
3. Reattach collection flask.

9.3. Changing Diaphragms and Valve Plates

- Conditions
- Vacuum pump system is switched off and mains plug is removed from the socket
 - Vacuum pump system is clean and free of hazardous materials

Tools and material

Qty	Material
1	Phillips-head screwdriver No. 2
1	4-mm hexagon screwdriver
1	Service Set (see chapter 11, page 40)
1	Felt-tip pen

Tab. 5

- Information on procedure
- ➔ Always replace diaphragms and valve plates together to maintain the pump performance.



WARNING

Health hazard due to dangerous substances in the vacuum pump system and pump!
 Depending on the substance transferred, caustic burns or poisoning are possible.

- ➔ Wear protective clothing if necessary, e.g. protective gloves.
- ➔ Flush vacuum pump system before replacing the diaphragms and valve plates (see chapter 9.2.1, page 30).



CAUTION

Danger of burns from hot pump parts
 The pump head or motor may be hot even after the pump has been shut off.

- ➔ Allow the pump to cool off after operation.

Remove pump head

1. Remove tubing from the inlet and outlet connectors of the pump.
2. Undo the two screws (Fig. 14/1) and nine screws (2) of the head cover (3).
3. Undo two screws (6) each, and remove both covers (5) at head cover (4).
4. Lift the head cover (3) off the pump housing (17).
5. Lift off head plate (9) with intermediate plates (10), (13) and (14).

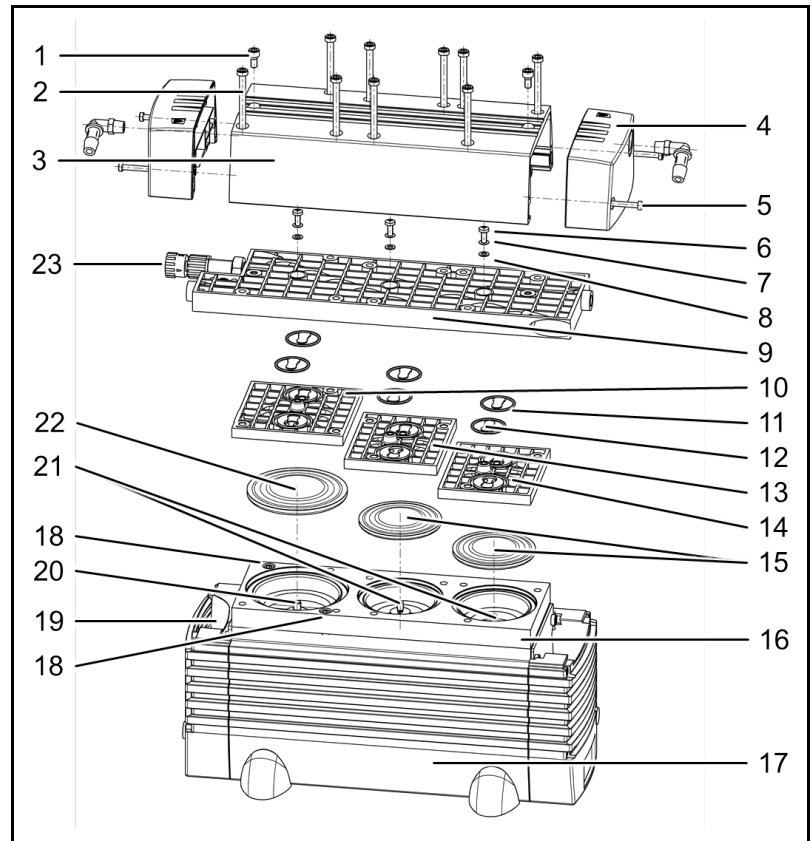

Fig. 14: Pump (exploded drawing, symbolic)

Change diaphragms

1. Turn the diaphragms (**15**) (2 pieces) and (**22**) (1 piece) outwards with your hands, counterclockwise. For this, turn the fan (**19**) such that you can easily grip each diaphragm with your hands.

i For diaphragms (**15**):
Make sure the diaphragm spacers being between diaphragm and connecting rod (**21**) do not fall into the pump housing.

If diaphragm spacers should adhere to the diaphragms, take them off and put them on the thread of the corresponding connecting rod.

In order to ensure the pneumatic output of the pump, it is essential that the diaphragm washers are subsequently remounted in the same quantity in each case.

2. Screw the new diaphragms (**15**) (2 pieces) and (**22**) (1 piece) onto the connecting rods (**20**) and (**21**) and tighten it by hand.

i Before you finally tighten the diaphragm, you are recommended to move the diaphragm to the upper dead center by rotating the fan (**19**).

3. Put head plate (**9**) with intermediate plates (**10**), (**13**) and (**14**) on adapter (**16**).

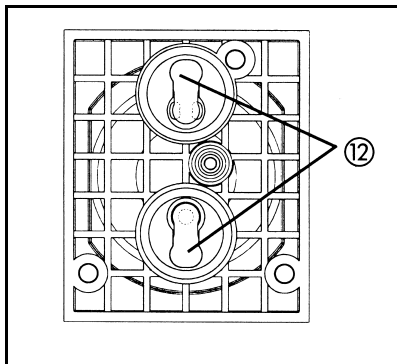

Fig. 15: Position of valve plates (12)

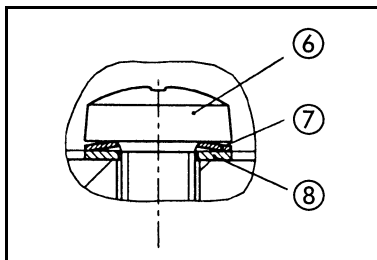

Fig. 16: Position and orientation of disk spring (7) and washer (8) at screw (6)

Change valve plates

1. Mark the position of head plate (9) and intermediate plate (10) relative to each other by a drawing line with a felt-tip pen. This helps avoid incorrect assembly later.
2. Mark the position of head plate (9) and intermediate plate (13) relative to each other by two drawing lines with a felt-tip pen.
3. Mark the position of head plate (9) and intermediate plate (14) relative to each other by three drawing lines with a felt-tip pen.
4. Undo the three screws (6) in head plate (9) and remove head plate from intermediate plates (10), (13) and (14).
5. Remove valve plates (12) and O-rings (11) from intermediate plates (10), (13) and (14).
 - i** Instead of lying on intermediate plate, O-rings could stick to head plate (9).
6. Lay the new valve plates (12) and the new O-rings (11) on the intermediate plates (10), (13) and (14).
 - i** Upper and lower sides of the valve plates are identical. For correct position see fig. 17.
7. Dispose of the old diaphragms and valve plates/sealings properly.

Mount pump head

1. Place head plate (9) on intermediate plates (10), (13) and (14) in the position indicated by the drawing lines.
 - i** At the front edge the three intermediate plates must lie in a line on which head plate is placed flushly.
2. Tighten the three screws (6) of head plate (9) carefully slightly hand-tight (tightening torque: 0.6 Nm).
 - i** For position and orientation of disk spring (7) and washer (8) of screw (6) see fig. 18.
3. Place head cover (3) on pump housing (17).
4. Tighten the nine screws (2) of head cover (3) slightly in the first instance. Start with the screws of medium pump stage, then tighten the screws on the right, and finally on the left.
5. Now, tighten the screws (2) firmly (tightening torque: 6 Nm); tighten the center screws first, then continue outward.
 - i** If the screws are stiff to turn, the intermediate plates do not lie in a line at front edge, or intermediate plates and head plate are not placed flushly (see step 1).
6. Remount the covers (4).
7. Tighten the two screws (1) on the head cover (tightening torque: 5 Nm).

Final steps

1. Reconnect vacuum pump system tubing.
2. Reconnect vacuum pump system to the electricity supply.

9.4. Replace overpressure valve on high performance condenser

Conditions

- Vacuum pump system is switched off and mains plug is removed from the socket
- Vacuum pump system is clean and free of hazardous materials

Information on procedure

**WARNING**

Health hazard due to dangerous substances in the vacuum pump system and pump!

Depending on the substance transferred, caustic burns or poisoning are possible.

- ➔ Wear protective clothing if necessary, e.g. protective gloves.
- ➔ Flush vacuum pump system before replacing overpressure valve (see chapter 9.2.1, page 30).

1. Unscrew and remove hose nozzle which connects the high performance condenser with the pressure side of the pump from high performance condenser.
2. Detach the old overpressure valve from screw socket of high performance condenser.
3. Slide on the new overpressure valve. Be aware that the overpressure port is completely covered.
4. Reconnect high performance condenser with pump.

10. Troubleshooting



Extreme danger from electrical shock!

→ Disconnect the pump power supply before working on the pump.

DANGER

→ Make sure the pump is de-energized and secure.

- Vacuum pump system as a whole: see table 7.
- Hand terminal: see table 8.
- Software operation: see table 9.

Vacuum pump system as a whole		
Problem	Cause	Solution
Vacuum pump system is switched on, but the mains switch does not light up.	Mains cable not plugged in.	→ Plug the mains cable for the vacuum pump system into a properly grounded power socket.
	No current in electricity network.	→ Check the electricity supply.
	Vacuum pump system fuses blown.	<ol style="list-style-type: none"> 1. Find and eliminate the cause of the overload. 2. Replace the mains fuse(s) of the vacuum pump system: <ul style="list-style-type: none"> ▪ Push the locking clip on the fuse drawer down (Fig. 3/4, p. 12) and pull the drawer out. ▪ Replace the defective fuse(s) (for fuse specifications see chapter 4.1, page 8; for fuse order numbers see chapter 11, p. 40). ▪ Push the fuse drawer back in until it clicks into position.
Required vacuum not generated even though pump is running.	Leaks in vacuum chamber.	<ol style="list-style-type: none"> 1. Run a test by closing the gas inlet (Fig. 2/7, p. 11). If the pump reaches the required vacuum, this confirms the presence of leaks in the vacuum chamber. 2. Eliminate leaks in the vacuum chamber.
	O-ring is not sitting correctly in the slot on the suction side of the collection flask.	<ul style="list-style-type: none"> → Adjust O-ring. → Replace if defective (for order number for O-ring, see chapter 11, p. 40).
	Leaks in hose connection.	<ul style="list-style-type: none"> → Check hoses are sitting correctly on hose nipples. → Replace any leaky hoses. → Replace any damaged hose nipples. → For ordering numbers see chapter 11, page 40.
	Hexagonal gland (Fig. 2/8, p. 12) loose.	→ Carefully tighten hexagonal gland with wrench.

Vacuum pump system as a whole		
Problem	Cause	Solution
	Leaks in venting valve.	<ul style="list-style-type: none"> ➔ Temporarily close the ventilation connection (Fig. 2/6, p. 12). If this stops the leak, leaks are present in the venting valve. In this case: ➔ Flush the venting valve: <ol style="list-style-type: none"> 1. Close the gas inlet (Fig. 2/7). 2. If necessary for safety reasons: Connect inert gas to ventilation connection. Observe the safety instructions in chapter 3. 3. Run the vacuum pump system at 100% pump capacity in <i>evacuation</i> mode. 4. Re-open the gas inlet. ➔ If problem persists, contact KNF Service.
	Condensation in pump head.	<ul style="list-style-type: none"> ➔ Dry system with fresh air or, if necessary for safety reasons, with an inert gas: <ol style="list-style-type: none"> 1. Using inert gas: Connect inert gas source with gas inlet (Fig. 2/7, p. 12) and start system up in <i>evacuation</i> mode (100% capacity). Observe the safety instructions in chapter 3. 2. Using air: Open gas line (Fig. 2/7, p. 12) to the surrounding environment and start system up in <i>evacuation</i> mode (100% capacity). 3. Close the gas inlet after 30 seconds, and leave the vacuum pump system running for 30 seconds under vacuum. 4. Repeat this process 3–5 times. ➔ If this problem occurs frequently, place the vacuum pump system at a higher level than the vacuum chamber.
	Gas outlet blocked on high-performance condenser.	<p>Risk of bursting of high-performance condenser!</p> <ul style="list-style-type: none"> ➔ Eliminate blocking of gas outlet.
	Worn diaphragms or valve plates.	<ul style="list-style-type: none"> ➔ Replace diaphragms and valve plates (chapter 9.3).
	Replaced diaphragms and valve plates.	<ul style="list-style-type: none"> ➔ Check that the correct diaphragm spacers are placed under the diaphragms. ➔ If necessary, carefully tighten the pump head fixing screws (Fig. 17/2, p. 33) in diagonally opposite sequence.

Vacuum pump system as a whole		
Problem	Cause	Solution
Pump not activated on process start-up, in spite of pressure decrease command.	Overcurrent protection of vacuum pump system has been activated.	<ul style="list-style-type: none"> ➔ Reset by switching the vacuum pump system off and back on. ➔ Check that there is no object blocking the pump fan (Fig. 17/20, p. 33) and make sure that adequate supply and removal of cool air is provided. ➔ Find and eliminate any other cause of pump overload.
Noisy pump.	Leaking hose connection.	<ul style="list-style-type: none"> ➔ Check that hoses are sitting correctly on hose nipples. ➔ Replace any leaking hoses. ➔ Replace any damaged hose nipples.
	Leaks at hose nipple on high-performance condenser.	➔ Tighten hose nipple at gas outlet (Fig. 2/17, p. 12).
	Leaks in overpressure valve on high-performance condenser.	➔ Check overpressure valve is sitting correctly; replace if necessary. For ordering number see chapter 11, page 40.

Tab. 6

Hand terminal		
Problem	Cause	Solution
Hand terminal display fails to light up.	Hand terminal not switched on.	➔ Switch hand terminal on.
Pressure display shows implausible values.	Unit of pressure for display has been changed.	➔ Set desired unit of pressure.
	Leaks in system.	➔ See Tab. 8, "Required vacuum not generated even though pump is running".
	Recalibration of pressure sensor required.	➔ Contact KNF Service.

Tab. 7

Software operation		
Problem	Cause	Solution
PC software unable to connect to vacuum pump system.	Vacuum pump system not switched on.	→ Switch vacuum pump system on.
	USB connection between system and PC is not operating correctly.	→ Check correct connection of USB cable. If necessary, pull out the USB cable and reinsert (USB interface reset).
Pressure display shows implausible values.	Unit of pressure for display has been changed.	→ Set desired unit of pressure.
	Leaks in system.	→ See Tab. 8, "Required vacuum not generated even though pump is running".
	Recalibration of pressure sensor required.	→ Contact KNF Service.

Tab. 8

Fault cannot be rectified

If you are unable to determine any of the specified causes, send the vacuum pump system to KNF Customer Service (see last page for the address).

1. Flush the vacuum pump system to free the pump head, tubing and glass vessels of dangerous or aggressive gases (see chapter 9.2.1, page 30).
2. Clean the vacuum pump system (see chapter 9.2.2, page 30).
3. Send the vacuum pump system, together with completed Health and Safety Clearance and Decontamination Form, to KNF stating the nature of the transferred medium.

11. Ordering Information

Spare parts Pump

Spare part	Order-No.
A spare parts kit SC 920G: 3 diaphragms, 6 valve plates and 6 O-rings (24 x 2)	305355

Tab. 9

Other spare parts

Spare part	Order-No.
Overpressure valve for high-performance condenser	047807
USB cable	136174
Mains cable D	026363
Mains cable CH	027523
Mains cable GB	029866
Mains cable USA/JP	027524
Tubes (yard ware)*	028187
Hose nipple gas inlet and pump connections (ID 10)	112005
Hose nipple ventilating (ID 6)	055958
Hose nipple for high performance condenser: gas connection (ID 10)	026237
Hose nipple for high performance condenser: coolant connection (ID 8)	025981
O-ring adapter on collection flask	047744
Collection flask 500 ml (coated)	047729
Flask clamp	025968
Fuse T 2.5	027575

Tab. 10

* Please specify the required length (in whole meters)

Accessories

Accessory	Order-No.
Coolant valve	117121
Chemical-resistant protective film for hand terminal display	117407

Tab. 11

12. Returns

Preparing for return

1. Flush the vacuum system with air for a few minutes (if necessary for safety reasons: with inert gas) at atmospheric pressure to free the pump head of dangerous or aggressive gases (see Chapter 9.2.1. Flushing Vacuum pump system).
- i** Please contact your KNF sales partner if the vacuum system cannot be flushed due to damage.
2. Remove the vacuum system.
3. Clean the vacuum system (see Chapter 9.2.2. Cleaning Vacuum pump system)
4. Send the pump together with the completed Health and Safety Clearance and Decontamination Form to KNF, stating the nature of the transferred medium.
5. Pack the device securely to prevent further damage to the product. If necessary, request original packaging for a fee.

Returns

KNF shall undertake to repair the vacuum system only under the condition that the customer presents a certificate regarding the medium that is pumped and the cleaning of the vacuum system. Please follow the instructions at knf.com/repairs here.

Contact your KNF sales partner directly if you require additional support for your return service.

KNF worldwide

Find your local KNF partner on www.knf.com