

TS2659

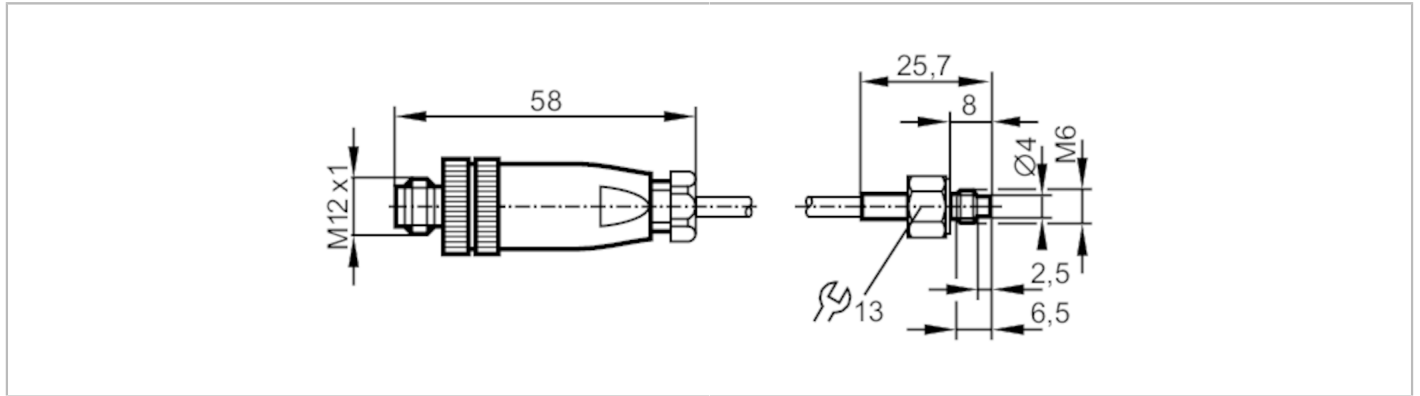

Temperature cable sensor with screw-in sensor

TS-PT100-SCREW-IN M6



Product characteristics		
Measuring range	-30...180 °C	-22...356 °F
Process connection	threaded connection M6 external thread	
Application		
Measuring element	1 x Pt 100; (to DIN EN 60751, class A)	
Installation	Contact sensor for solid bodies	
Electrical data		
Protection class	III	
Measuring/setting range		
Measuring range	-30...180 °C	-22...356 °F
Accuracy / deviations		
Accuracy	[K]	± (0,15 K + 0,002 x t)
Reaction times		
Dynamic response T05 / T09	[s]	3 / 8; (according to DIN EN 60751)
Operating conditions		
Protection	IP 67	
Tests / approvals		
MTTF	[years]	10377.8
Mechanical data		
Weight	[g]	110.7
Housing	tubular	
Design	screw-in sensor	
Material	stainless steel (1.4404 / 316L)	
Process connection	threaded connection M6 external thread	
Probe diameter	[mm]	4
Remarks		
Pack quantity	1 pcs.	

TS2659



Temperature cable sensor with screw-in sensor

TS-PT100-SCREW-IN M6

Electrical connection

Cable: 2 m, silicone

Connector: 1 x M12; coding: A



Connection

