

# SU2050

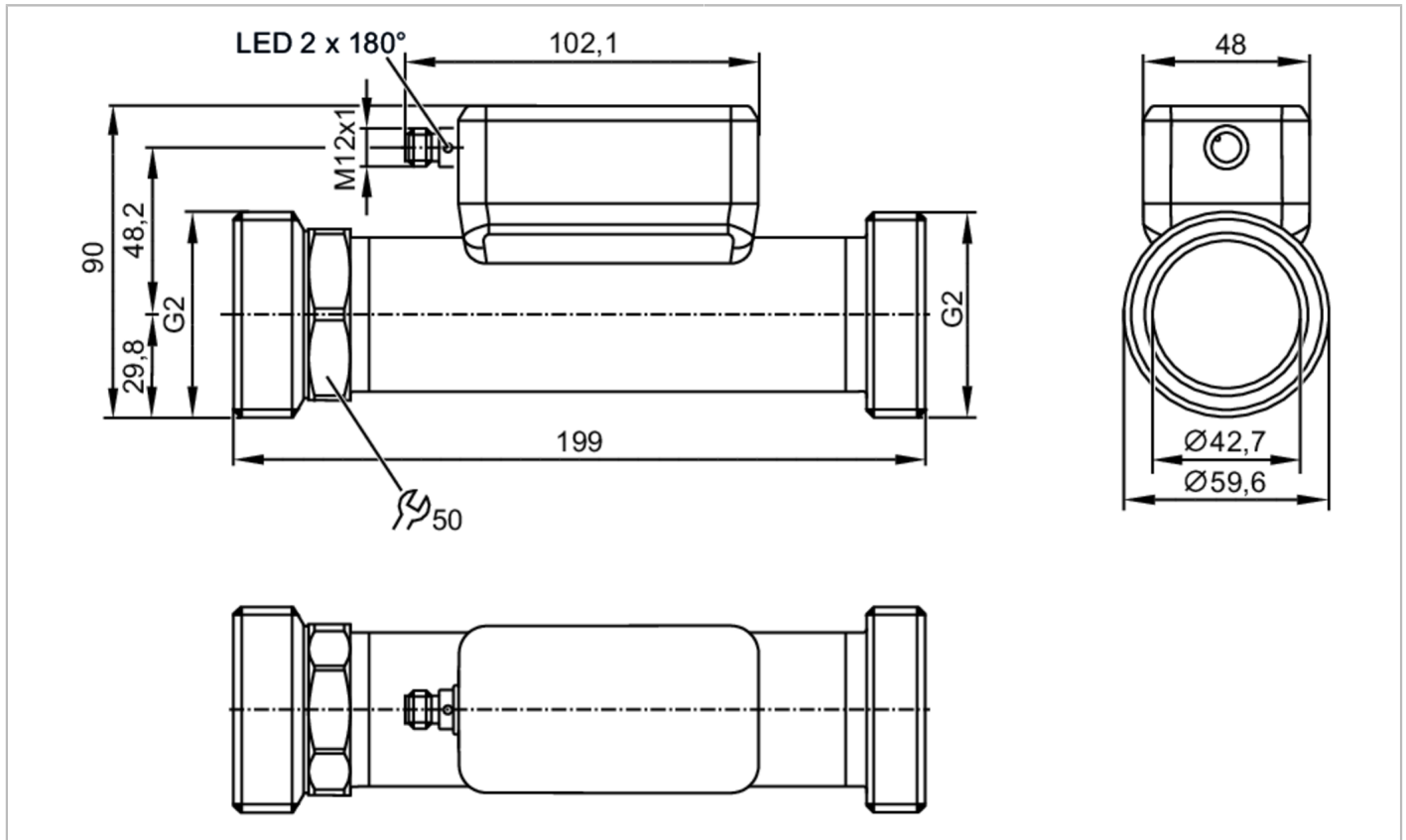

## Ultrasonic flow meter

SUR21XJBFRKG/US



ACS KTW/W270 Reg31

### Product characteristics

Number of inputs and outputs	Number of digital outputs: 2; Number of analog outputs: 1			
Measuring range	5...1000 l/min	0.3...60 m³/h	79...15850 gph	1.32...264.18 gpm
Nominal diameter	DN50 (2")			
Process connection	threaded connection G 2 external thread DN50			

### Application

System	gold-plated contacts	
Application	use in mobile and industrial applications	
Media	ultra-pure water; water; water-based media; glycol solutions; oils (of high and low viscosity); Coolants	
Note on media	water-based media: for media with >10 % additives, the repeatability is the only available value	
	low-viscosity oils with viscosity: 7...40 mm²/s (40 °C)	
	high-viscosity oils with viscosity: 30...68 mm²/s (40 °C)	
Medium temperature	-40...120 °C	-40...248 °F
Min. burst pressure	150 bar	15 MPa
Pressure rating	100 bar	10 MPa
Vacuum resistance [mbar]	-1000	

### Electrical data

Operating voltage [V]	8...32 DC; (to SELV/PELV)
Current consumption [mA]	< 175
Protection class	III

# SU2050



## Ultrasonic flow meter

SUR21XJBFRKG/US

Reverse polarity protection	yes
Power-on delay time [s]	5
Measuring principle	ultrasonic

### Inputs / outputs

Total number of inputs and outputs	2
Number of inputs and outputs	Number of digital outputs: 2; Number of analog outputs: 1

### Inputs

Inputs	OUT2	counter reset
--------	------	---------------

### Outputs

Total number of outputs	2
Output signal	OUT1 switching signal; pulse signal; diagnostic signal; totalizer switching signal; frequency signal; IO-Link
	OUT2 switching signal; pulse signal; diagnostic signal; totalizer switching signal; analog signal
Electrical design	PNP/NPN
Number of digital outputs	2
Output function	normally open / closed; (configurable)
Max. voltage drop switching output DC [V]	2
Permanent current rating of switching output DC [mA]	100
Switching frequency DC [Hz]	0...10000
Number of analog outputs	1
Analog current output [mA]	4...20; (scalable)
Max. load [Ω]	500
Analog voltage output [V]	0...10 / 0.5...4.5; (scalable)
Min. load resistance [Ω]	2000
Pulse output	flow rate meter
Short-circuit protection	yes
Type of short-circuit protection	yes (non-latching)
Overload protection	yes

### Measuring/setting range

Measuring range	5...1000 l/min	0.3...60 m³/h	79...15850 gph	1.32...264.18 gpm
Resolution	0.1 l/min	0.001 m³/h	1 gph	0.01 gpm
Note on factory setting	l/min			
	°C			
Set point SP	10.5...1000 l/min	0.63...60 m³/h	166...15850 gph	2.77...264.17 gpm
Reset point rP	5.3...994.8 l/min	0.318...59.688 m³/h	84...15768 gph	1.4...262.8 gpm
Analog start point ASP	-1000...800 l/min	-60...48000 m³/h	-15850...12680 gph	-264.17...211.34 gpm
Analog end point AEP	-800...1000 l/min	-48...60 m³/h	-12680...15850 gph	-211.34...264.17 gpm
Low flow cut-off LFC	5...50 l/min	0.3...3 m³/h	79...793 gph	1.32...13.21 gpm
Frequency end point, FEP	200.6...1000 l/min	12.037...60 m³/h	3180...15850 gph	53...264.17 gpm
Frequency at the end point FRP [Hz]	1...10000			

# SU2050



## Ultrasonic flow meter

SUR21XJBFRKG/US

Volumetric flow quantity monitoring		
Pulse length [s]	0.002...2	
Pulse value	0.1...99990000 l; 0.03...26414563.515 gal	
Temperature monitoring		
Measuring range	-40...120 °C	-40...248 °F
Resolution	0.1 °C	0.1 °F
Set point SP	-40...119.4 °C	-40...247 °F
Reset point rP	-40...88 °C	-40...190.4 °F
Analog start point	-8...120 °C	17.6...248 °F
Analog end point	-40...88 °C	-40...190.4 °F
Frequency start point, FSP	-8...120 °C	17.6...248 °F
Frequency end point, FEP	-40...119.4 °C	-40...247 °F
Frequency at the end point FRP [Hz]	1...10000	
Accuracy / deviations		
Flow monitoring		
Accuracy (in the measuring range)	only up to 100 °C; at higher temperatures, only the repeatability is within the specification.	
Accuracy (in the measuring range)	glycol solutions (35%)	±(5,0 % MW + 0,5 % MEW)
	high-viscosity oils with viscosity 46mm <sup>2</sup> /s (40°C)	±(5,0 % MW + 0,5 % MEW)
	low-viscosity oils with viscosity 10mm <sup>2</sup> /s (40°C)	±(5,0 % MW + 0,5 % MEW)
	water	± (1,0 % MW + 0,5 % MEW)
Repeatability	± 0,2 % MEW	
Temperature monitoring		
Accuracy [K]	± 2,5 (Q > 5 % MEW)	
Temperature coefficient [% of the span / 10 K]	0,2	
Reaction times		
Flow monitoring		
Response time [s]	< 0.25; (dAP = 0, T09)	
Damping process value dAP [s]	0...5	
Temperature monitoring		
Dynamic response T05 / T09 [s]	5,7 / 86	
Software / programming		
Diagnostic functions	direction of flow detection; signal quality	
Interfaces		
Communication interface	IO-Link	
Transmission type	COM2 (38,4 kBaud)	
IO-Link revision	1.1.3	
SDCI standard	IEC 61131-9: 2013-07	
Profiles	BLOB	Binary Large Object transfer
	Common - I&D	Identification and Diagnosis
Required master port class	A	
Process data analog	3	

# SU2050



## Ultrasonic flow meter

SUR21XJBFKRG/US

Process data binary		2
Min. process cycle time	[ms]	9.6
IO-Link process data (cyclical)	<b>Function</b>	<b>bit length</b>
	totalizer	32
	Flow monitoring	32
	Temperature monitoring	32
	status	4
	Output 1	1
	Output 2	1
Supported DeviceIDs	<b>Type of operation</b>	<b>DeviceID</b>
	default	1841

### Operating conditions

Ambient temperature	[°C]	-25...60
Storage temperature	[°C]	-40...80
Protection		IP 67; IP 69K

### Tests / approvals

EMC		DIN 61326-1:2021	
Shock resistance		DIN IEC 68-2-27	20 g (11ms)
Vibration resistance		DIN IEC 68-2-6	20 g (10...2000Hz)
MTTF	[years]		136
UL approval	UL approval number		I036
	File number UL		E174189
Pressure equipment directive		can be used for group 2 fluids; group 1 fluids on request	

### Mechanical data

Weight	[g]	1180
Housing		rectangular
Inlet pipe length		5 x DN
Outlet pipe length		1 x DN
Dimensions	[mm]	199 x 59.6 x 90
Material		housing: stainless steel (1.4404 / 316L); connector: PEI, FKM
Materials (wetted parts)		Pipe section: stainless steel (1.4404 / 316L); Process connection sealing: NBR fiber-reinforced
Nominal diameter		DN50 (2")
Process connection		threaded connection G 2 external thread DN50
Surface characteristics Ra/Rz of the wetted parts		Ra < 1.25 µm

### Displays / operating elements

Display	operating status	1 x LED, green
---------	------------------	----------------

### Accessories

Items supplied	Gasket 2, NBR fiber-reinforced package insert
----------------	--

### Remarks

Remarks	MW = Measured value
	MEW = Final value of the measuring range
	pulse and totalizer signal are only available for one of the two outputs
	the accuracy indications are adhered to over the entire application area

# SU2050



## Ultrasonic flow meter

SUR21XJBFRKG/US

Pack quantity

1 pcs.

### Electrical connection

Connector: 1 x M12; coding: A; Contacts: gold-plated



### Connection

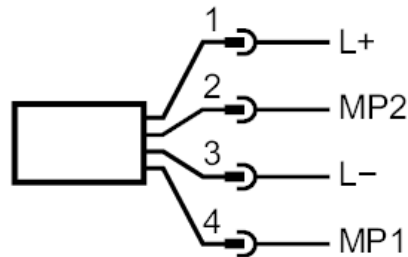

1 (L+)	L+	
2 (OUT2)	MP2	DO, AO, Reset
3 (L-)	L-	
4 (OUT1)	MP1	DO, IO-Link

### Electrical connection - plug

### Diagrams and graphs

Note on pressure loss

