

SMF621

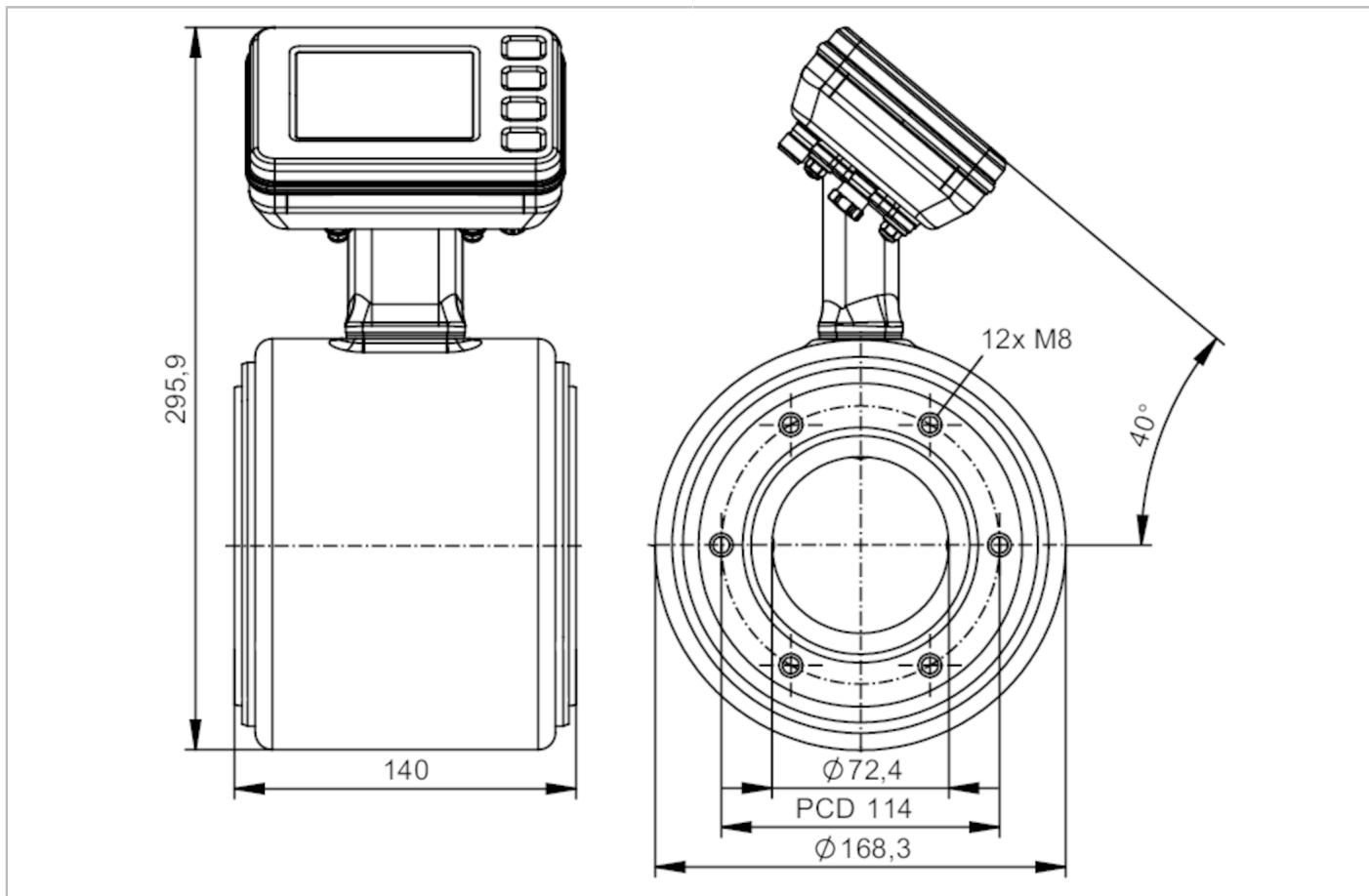

Magnetic-inductive flow meter

SMG80KGFFRKG/USD



EC 1935/2004

FCM



Product characteristics

Measuring range	30...3000 l/min	1800...180000 l/h	8...792.5 gpm	0.32...32.64 ft/s
Nominal diameter	DN80 (3")			
Process connection	ifm-specific device flange			

Application

System	gold-plated contacts			
Application	food and beverage industry			
Media	Conductive liquids; water; water-based media			
Note on media	food products such as beer, milk, fruit juices, soft drinks, ketchup, yogurt, yogurt toppings, ice cream conductivity: $\geq 5 \mu\text{S/cm}$			
Medium temperature	-20...150 °C	-4...302 °F		
Min. burst pressure	543.75 psi	3.75 MPa		
Pressure rating	362.5 psi	2.5 MPa		

Electrical data

Operating voltage	[V]	18...32 DC
Current consumption	[mA]	250; (24V)
Protection class		III
Reverse polarity protection		yes
Power-on delay time	[s]	< 5

SMF621



Magnetic-inductive flow meter

SMG80KGFFRKG/USD

Measuring principle	magnetic-inductive			
Inputs / outputs				
Total number of inputs and outputs	2			
Inputs				
Inputs	OUT2	external totalizer reset		
Outputs				
Total number of outputs	2			
Output signal	OUT1	pulse signal; totalizer switching signal; diagnostic signal; IO-Link		
	OUT2	analog signal; pulse signal; totalizer switching signal; diagnostic signal		
Electrical design	PNP/NPN			
Pulse output	flow rate meter			
Short-circuit protection	yes			
Type of short-circuit protection	yes (non-latching)			
Overload protection	yes			
Analog				
Number of analog outputs	1			
Analog current output [mA]	4...20; (skalierbar)			
Max. load [Ω]	500			
Resolution of analog output	0.38 μ A			
Digital				
Number of digital outputs	2			
Max. voltage drop switching output DC [V]	2			
Permanent current rating of switching output DC [mA]	100			
Switching frequency DC [Hz]	0...10000			
Measuring/setting range				
Measuring range	30...3000 l/min	1800...180000 l/h	8...792.5 gpm	0.32...32.64 ft/s
Display range	-3600...3600 l/min	-216000...216000 l/h	-951.02...951.02 gpm	-39.4...39.4 ft/s
Resolution	0.1 l/min	200 l/h	0.01 gpm	0.01 ft/s
Note on factory setting	0...200 gpm			
Analog start point ASP	-3000...2400 l/min	-180000...144000 l/h	-792.5...778.08 gpm	-32.8...26.24 ft/s
Analog end point AEP	-2400...3000 l/min	-144000...180000 l/h	-778.08...792.5 gpm	-26.24...32.8 ft/s
Low flow cut-off LFC	0...2400 l/min	0...144000 l/h	0...778.08 gpm	0...26.24 ft/s
Pulse length [s]	0.00005...2			
Pulse value	0.038...99990000 l			
Temperature monitoring				
Measuring range	-20...150 °C		-4...302 °F	
Display range	-20...150 °C		-4...302 °F	
Resolution	0.01 °C		0.1 °F	
Analog start point	-20...116 °C		-4...240.8 °F	
Analog end point	14...150 °C		57.2...302 °F	

SMF621



Magnetic-inductive flow meter

SMG80KGFFRKG/USD

Conductivity monitoring		
Measuring range	[μ S/cm]	100...100000
Display range	[μ S/cm]	0...10000000
Resolution	[μ S/cm]	1
Analog start point	[μ S/cm]	0...80000
Analog end point	[μ S/cm]	20000...100000
Accuracy / deviations		
Volumetric flow monitoring		
Accuracy (under reference conditions)	with optional factory calibration (availability is being planned)	$\pm (0,2 \% \text{ MW} + 2 \text{ mm/s})$
	standard	$\pm (0,5 \% \text{ MW} + 1,5 \text{ mm/s})$
Repeatability		0,1% MW
Temperature monitoring		
Accuracy	[K]	± 1
Repeatability	[K]	$\pm 0,5$
Conductivity monitoring		
Accuracy (in the measuring range)	in the range of 100...20000 μ S/cm	$\pm 10\% \text{ MW}$
	in the range of 20000...100000 μ S/cm	$\pm 20\% \text{ MW}$
Repeatability		$\pm 5\% \text{ MW}$
Reaction times		
Volumetric flow monitoring		
Response time	[s]	< 0.3
Damping process value dAP	[s]	0...5
Temperature monitoring		
Response time	[s]	< 3; (Flow velocity: $\geq 0,5 \text{ m/s}$)
Conductivity monitoring		
Response time	[s]	< 2
Software / programming		
Diagnostic functions		direction of flow detection; liquid detection
Interfaces		
Communication interface		IO-Link
Transmission type		COM3 (230,4 kBaud)
IO-Link revision		1.1.3
SDCI standard		IEC 61131-9
Profiles	Smart Sensor - SSP 4.3.4	Measuring and Switching Sensor, floating point, 4 channel
	BLOB	Binary Large Object transfer
	Common - I&D	Identification and Diagnosis
	Extension	Sensor Control Wide
	Extension	Quantity detection, switches when value exceeds the setpoint
	Function	Locator
Function	ProductURI	
SIO mode		yes

SMF621



Magnetic-inductive flow meter

SMG80KGFFRKG/USD

Required master port class	A	
Process data analog	6	
Process data binary	8	
Min. process cycle time [ms]	1.9	
IO-Link process data (cyclical)	Function	bit length
	totalizer	32
	flow	32
	temperature	32
	conductivity	32
	status	4
	binary switching information	8
IO-Link functions (acyclical)	direction of flow detection; totalizer; memory; operating hours counter; internal temperature; simulation function	
Supported DeviceIDs	Type of operation	DeviceID
	default	1799

Operating conditions		
Ambient temperature	-20...65 °C	-4...149 °F
Storage temperature	-20...80 °C	-4...176 °F
Protection	IP 67; IP 69; (to DIN EN 60529)	

Tests / approvals		
EMC	DIN 61326-1	
CPA approval	model number	SMF
	accuracy class	0,5
Shock resistance	DIN IEC 68-2-27	20 g (18ms)
Vibration resistance	DIN IEC 68-2-6	5 g (10...2000Hz)
MTTF [years]	81	
UL approval	UL approval number	I031
Pressure equipment directive	sound engineering practice; can be used for group 2 fluids; group 1 fluids on request	

Mechanical data		
Weight [g]	7630.9	
Housing	tubular	
Inlet pipe length	5 x DN	
Outlet pipe length	2 x DN	
Dimensions [mm]	Ø 168.3 / L = 140	
Material	housing: stainless steel (1.4404 / 316L); flange: stainless steel (1.4301 / 304); electronics fixture: stainless steel (1.4301 / 304); electronics: stainless steel (1.4404 / 316L); Display: polysulfone; Display-sealing: FKM; LED ring: PP	
Materials (wetted parts)	Pipe section: PFA; electrodes: stainless steel (1.4435 / 316L)	
Nominal diameter	DN80 (3")	
Process connection	ifm-specific device flange	
Surface characteristics Ra/Rz of the wetted parts	Ra < 0.4 µm	

SMF621



Magnetic-inductive flow meter

SMG80KGFFRKG/USD

Displays / operating elements		
Display	process value	full graphics TFT display, multi-color 3,5" 320 x 240 Pixel
		display layouts: 4
		display rotation: 4 x 90°
	operating status	LED ring, three-color
Display unit	l/min; l/h; hl/min; hl/h; m³/min; m³/h; m/s; gpm; gph; ft/s; °C; °F; µS/cm; S/m; ms/cm	
Factory setting	gpm; °F; µS/cm	
Language	German; English; Spanish; French; Italian; Japanese; Korean; Portuguese; Chinese	
Operating elements	4	capacitive pushbuttons
Remarks		
Remarks	MW = Measured value	
	MEW = Final value of the measuring range	
	pulse and totalizer signal are only available for one of the two outputs	
	reference conditions (1/2): water (free of gas bubbles), 15...35 °C, process connection: DIN32676 series A, pipe standard suitable for process connection	
	reference conditions (2/2): inlet pipe length 10xDN, outlet pipe length 5xDN, device settling time: 30 minutes, device orientation: horizontal, display orientation: up	
	accuracy specifications according to factory certificate on delivery	
Pack quantity	1 pcs.	

Electrical connection

Connector: 1 x M12; coding: A; Contacts: gold-plated



Connection

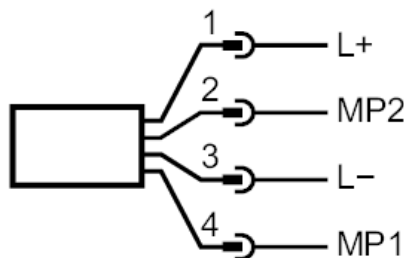

SMF621



Magnetic-inductive flow meter

SMG80KGFFRKG/USD

Electrical connection - plug

1	L+	
2	MP2	DO2, AO, Reset
3	L-	
4	MP1	DO1, IO-Link

AO: analog output; DO: digital output; MP: multi-function connection