

SF620A

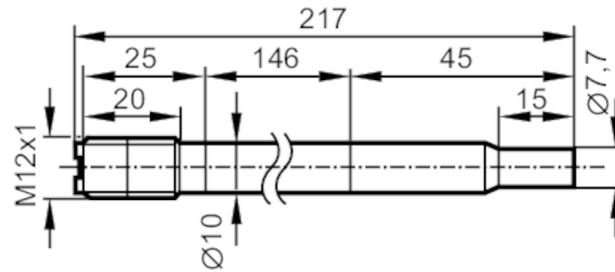

Flow sensor for connection to an evaluation unit

SFG10ABB/2G /US-100



Product characteristics	
Probe length L	[mm] 15...156
Process connection	Clamp fitting Ø 10 mm
Application	
System	gold-plated contacts
Installation	Sensor suitable for clamp fitting
Media	Liquids; Gases
Medium temperature	[°C] -20...70
Pressure rating	30 bar 3 MPa
Liquids	
Installation	Sensor suitable for clamp fitting
Medium temperature	[°C] -20...70
Gases	
Medium temperature	[°C] -20...70
Electrical data	
Connection to control monitor	VS2000 Exi (PTB 01 ATEX 2075)
Measuring/setting range	
Probe length L	[mm] 15...156
Liquids	
Setting range	[cm/s] 3...300
Greatest sensitivity	[cm/s] 3...60
Gases	
Setting range	[cm/s] 200...3000
Greatest sensitivity	[cm/s] 200...800
Accuracy / deviations	
Max. temperature gradient of medium	[K/min] 15
Reaction times	
Response time	[s] 1...10
Liquids	
Response time	[s] 1...10

SF620A



Flow sensor for connection to an evaluation unit

SFG10ABB/2G /US-100

Gases	
Response time	[s] 1...10
Operating conditions	
Ambient temperature	[°C] -20...70
Protection	IP 67
Tests / approvals	
Approval	DMT 03 ATEX E091; IECEx BVS 06.0007
ATEX marking	II 2G Ex ia IIC T4 Gb
Shock resistance	DIN IEC 68-2-27 40 g (11 ms)
Vibration resistance	DIN IEC 68-2-6 10 g (55...2000 Hz)
MTTF	[years] 8272
Safety classification	
Max. internal capacitance	[nF] 0.4
Max. internal inductance	[µH] 2
Temperature class	T4
Mechanical data	
Weight	[g] 123
Housing	tubular
Dimensions	[mm] Ø 10 / L = 217
Material	stainless steel (1.4404 / 316L) several parts, welded
Materials (wetted parts)	stainless steel (1.4404 / 316L) several parts, welded
Process connection	Clamp fitting Ø 10 mm
Probe diameter	[mm] 7.7
Accessories	
Accessories (optional)	Clamp adapter: R 1/2, E40160 Clamp adapter: 1/2" NPT, E40174
Remarks	
Remarks	In principle, the type test according to 94/9/EC (ATEX) only takes atmospheric conditions into account (0.8...1.1 bar). For pressures outside this range use must be assessed and approved by the user. Adhere to the operating instructions and the type test certificate.
Pack quantity	1 pcs.
Electrical connection	
Connector: 1 x M12; coding: A; Contacts: gold-plated; Maximum cable length: 100 m	

SF620A



Flow sensor for connection to an evaluation unit

SFG10ABB/2G /US-100

Connection

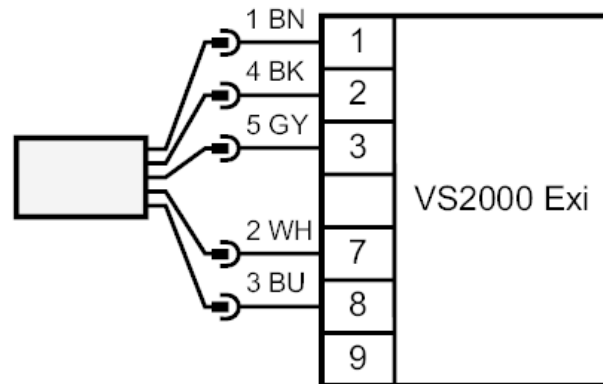

Core colors :
BN = brown
BU = blue
BK = black
WH = white
GY = grey