

SA4314

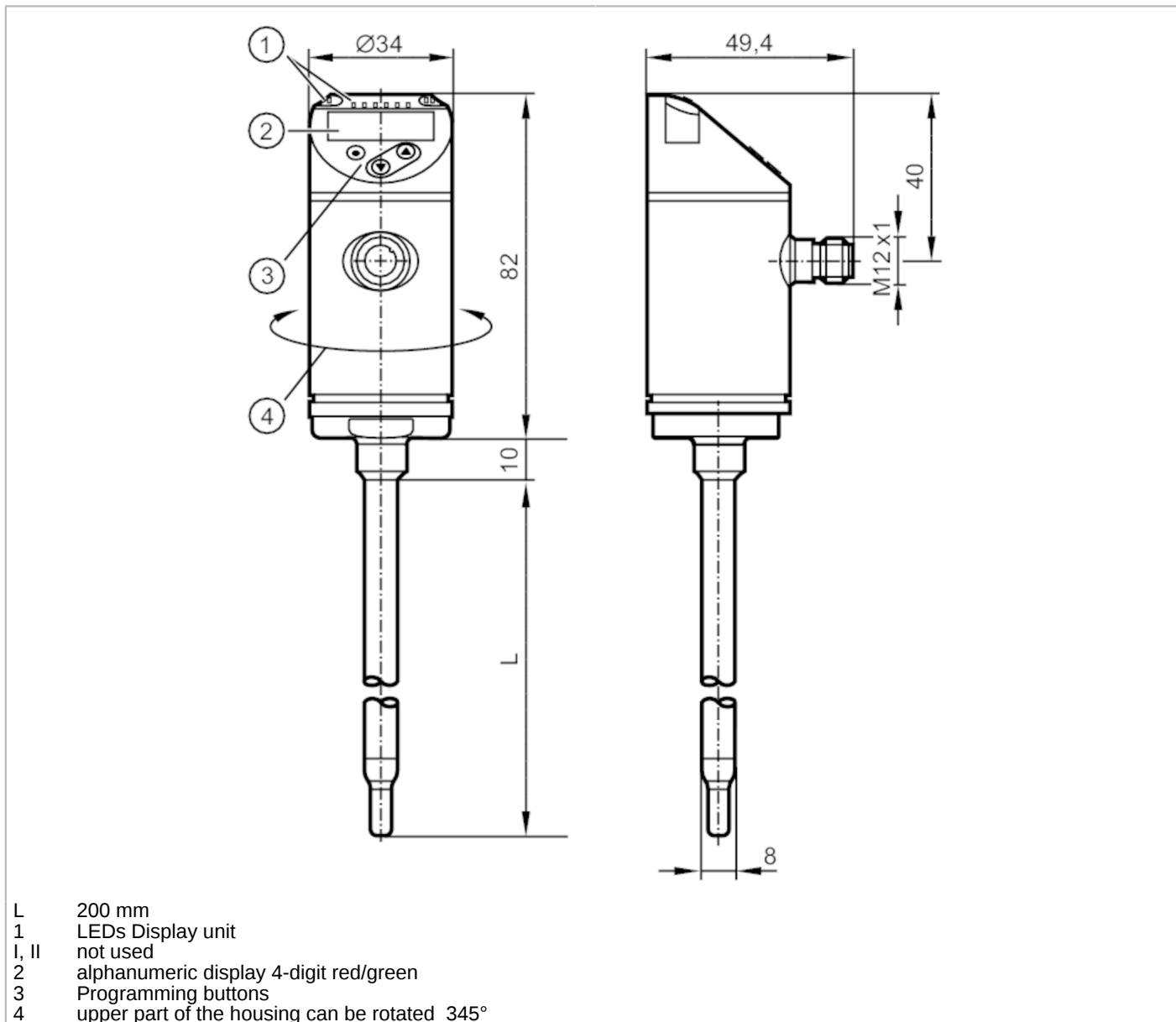

Flow sensor

SAEXXXB50KG/US-100



Product characteristics

Number of inputs and outputs	Number of analog outputs: 2
Process connection	Clamp fitting Ø 8 mm

Application

System	gold-plated contacts
Media	water; glycol solutions; air; oils
Note on media	low-viscosity oils with viscosity: ≤ 40 mm ² /s (104 °F) high-viscosity oils with viscosity: > 40 mm ² /s (104 °F)
Medium temperature [°F]	-4...212
Pressure rating	50 bar 5 MPa

Electrical data

Operating voltage [V]	18...30 DC
-----------------------	------------

SA4314



Flow sensor

SAEXXXB50KG/US-100

Current consumption	[mA]	< 100
Protection class		III
Reverse polarity protection		yes
Power-on delay time	[s]	10
Measuring principle		calorimetric

Inputs / outputs

Number of inputs and outputs	Number of analog outputs: 2	
------------------------------	-----------------------------	--

Outputs

Total number of outputs		2
Output signal		analog signal
Number of analog outputs		2
Analog current output	[mA]	4...20; (scalable)
Max. load	[Ω]	350
Short-circuit protection		yes
Type of short-circuit protection		yes (non-latching)
Overload protection		yes

Measuring/setting range

Probe length L	[mm]	200
Operating mode		relative; absolutely liquid; absolutely gaseous; (absolute: reference measurement recommended; Factory setting: relative)

Liquids

Resolution	[ft/s]	0.05
Analog start point ASP	[ft/s]	0...7.95
Analog end point AEP	[ft/s]	1.9...9.85

Gases

Resolution	[ft/s]	2
Analog start point ASP	[ft/s]	0...264
Analog end point AEP	[ft/s]	64...328

Temperature monitoring

Measuring range	[°F]	-4...212
Resolution	[°F]	0.5
Analog start point	[°F]	-4...169
Analog end point	[°F]	39...212
In steps of	[°F]	0.5

Liquid media - absolute operating mode

Setting range	[ft/s]	0.15...9.85
Greatest sensitivity	[ft/s]	0.15...9.85

Liquid media - relative operating mode

Setting range	[ft/s]	0.15...19.5
Greatest sensitivity	[ft/s]	0.15...9.85

Gases - operating mode "absolute"

Setting range	[ft/s]	6...328
---------------	--------	---------

SA4314



Flow sensor

SAEXXXB50KG/US-100

Greatest sensitivity	[ft/s]	6...328
Gases - operating mode "relative"		
Setting range	[ft/s]	6...656
Greatest sensitivity	[ft/s]	6...328
Accuracy / deviations		
Temperature drift	[cm/s x 1/K]	0,01 fps x 1/K (< 68 °F; > 158 °F)
Max. temperature gradient of medium	[K/min]	100
Absolute operating mode		
Repeatability		0,05 m/s; (water; Flow velocity: 0,05...3 m/s)
Relative operating mode		
Accuracy		± (7 % MW + 2 % MEW); (for relative mode in the range of maximum sensitivity under the following conditions:; water: 68...158 °F; inlet length: 5 ft; DN25 (DIN 2448); mounting position according to instructions; Accuracy can differ for other media and mounting positions.)
Repeatability		0,05 m/s; (water; Flow velocity: 0,05...3 m/s)
Temperature monitoring		
Temperature drift		± 0,003 K/°F
Accuracy	[K]	± 0,3 / ± 1; (water; Flow velocity: 1...9,85 fps / air; Flow velocity: > 32,8 fps)
Reaction times		
Response time	[s]	0.5; (T09; water; glycol: 0,8 s; air: 7 s; oil: 1,8 s; each T09)
Temperature monitoring		
Dynamic response T05 / T09	[s]	1,5 (T09); (water; Flow velocity: 1...9,85 fps)
Software / programming		
Parameter setting options		medium selection; Damping; Teach function; display can be rotated and switched off; standard unit of measurement; process value color
Operating conditions		
Ambient temperature	[°F]	-40...176
Storage temperature	[°F]	-40...212
Protection		IP 65; IP 67
Tests / approvals		
EMC		DIN EN 60947-5-9
Shock resistance		DIN EN 60068-2-27 50 g (11 ms)
Vibration resistance		DIN EN 60068-2-6 5 g (10...2000 Hz)
MTTF	[years]	179
UL approval		UL approval number I018 File number UL E174189
Mechanical data		
Weight	[g]	310.5
Housing		tubular
Dimensions	[mm]	Ø 8 / L = 292
Material		stainless steel (1.4404 / 316L); PBT-GF20; PBT-GF30
Materials (wetted parts)		stainless steel (1.4404 / 316L)
Process connection		Clamp fitting Ø 8 mm

SA4314



Flow sensor

SAEXXXB50KG/US-100

Displays / operating elements		
Display	Display unit	6 x LED, green (% , fps, gpm, cfm, °F, 10 ³)
	Measured values	alphanumeric display, red/green 4-digit
Remarks		
Remarks		MW = Measured value MEW = Final value of the measuring range
Pack quantity		1 pcs.

Electrical connection

Connector: 1 x M12; coding: A; Contacts: gold-plated



Connection

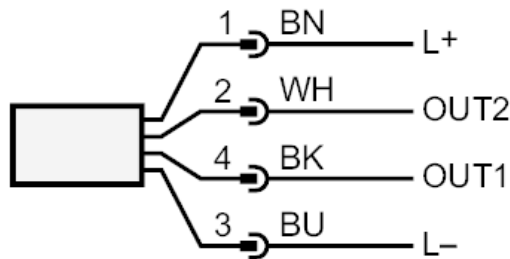

OUT1: analog output Temperature monitoring
OUT2: analog output Volumetric flow quantity monitoring
Core colors :
BK = black
BN = brown
BU = blue
WH = white