

R2D201

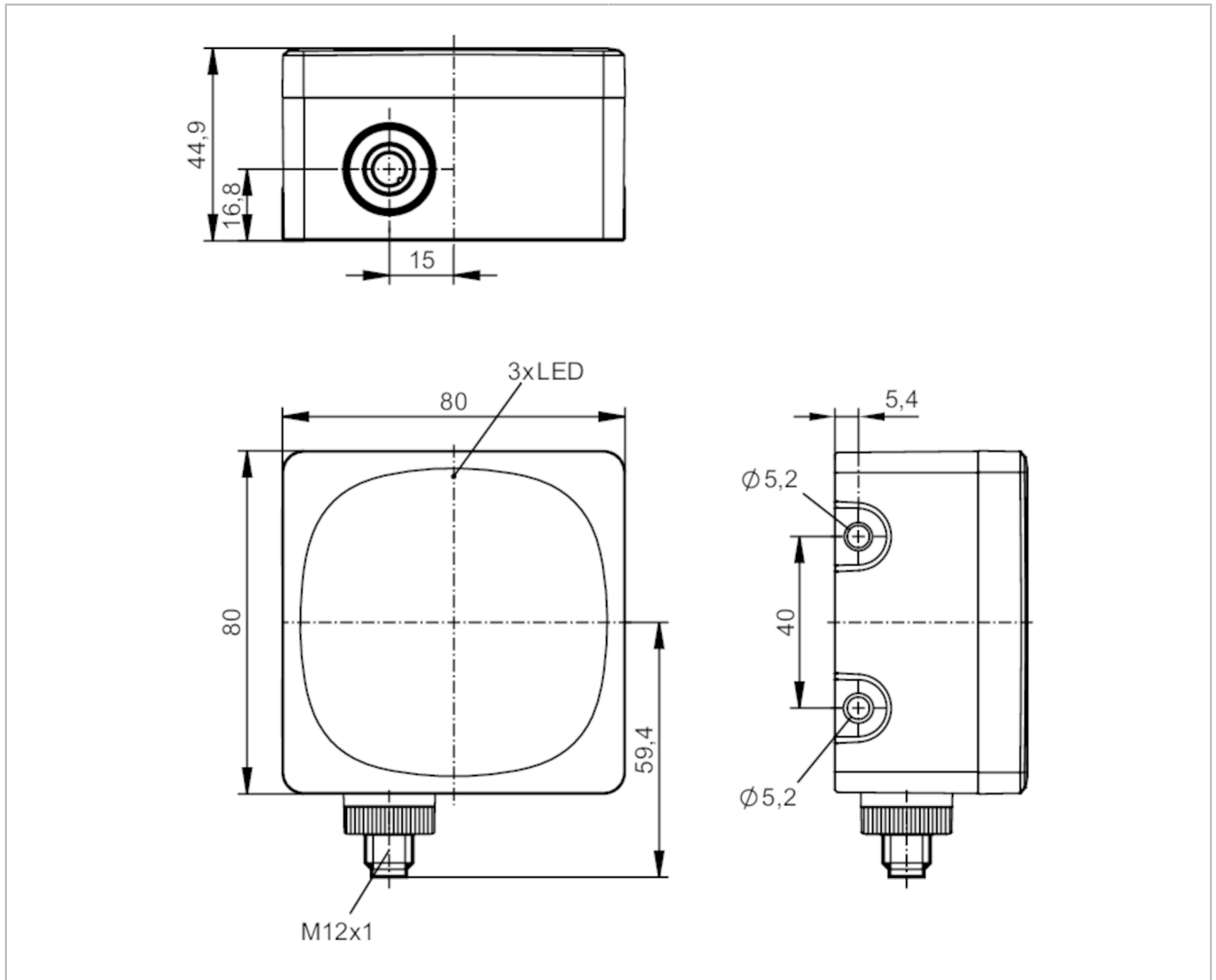

Radar area sensor

R2DBA00KG/US/CAN



Product characteristics	
Communication interface	CAN
Housing	rectangular
Dimensions [mm]	80 x 80 x 45
Application	
Radio approval for	EU/RED; USA; Canada; Great Britain; Australia; Chile; Brazil; Mexico; Namibia; New Zealand; South Africa
Note on radio approval	The list of countries applying the European Radio Equipment Directive 2014/53/EU (RED) can be found under "Downloads".
Electrical data	
Operating voltage [V]	9...32 DC; (to SELV/PELV ; energy-limited circuits according to IEC/UL 61010-1 3rd ed. cl. 9.4)
Current consumption [mA]	< 300; (mean value: 150 mA)
Power consumption [W]	9; (maximum)
Protection class	III

R2D201



Radar area sensor

R2DBA00KG/US/CAN

Reverse polarity protection	yes
Max. power-on delay time [ms]	1000
Operating frequency [GHz]	77...81
Maximum radiated average power spectral density EIRP [dBm/MHz]	-9
Radiated peak power EIRP [dBm]	27

Monitoring range

Range [m]	0.1...50; (based on E23014)	
Angle of aperture cylindrical [°]	Horizontal	140
	vertical	30
Note	static objects in the range < 1 m are not stably detected in area mode	

Measuring/setting range

Measuring range [m]	0.1...50; (see diagram:)
Sampling rate [Hz]	20

Software / programming

Parameter setting options	via PC with ifm Vision Assistant
---------------------------	----------------------------------

Interfaces

Communication interface	CAN
Number of CAN interfaces	1
Transmission rate	250 (125...1000) kBaud
Protocol	SAE J1939
Factory settings	Baud rate: 250
	device address (ECU): 126
	UDS interface: 1000 kBaud
Usage type	Parameter setting; Data transmission
Note	For further information please refer to the software manual available under "Downloads"

Operating conditions

Ambient temperature [°C]	-40...85
Storage temperature [°C]	-40...85
Protection	IP 65; IP 66; IP 67; IP 69K; (with mounted connectors or protective caps)

Tests / approvals

EMC	DIN EN 61000-4-2 ESD	4 kV CD / 8 kV AD
	DIN EN 61000-4-3 HF radiated	10 V/m
	DIN EN 61000-4-4 Burst	2 kV
	DIN EN 61000-4-6 HF conducted	10 V
	DIN EN 61000-6-2	noise immunity / industrial environments
	EN 55032 emission	class A
Impact resistance	IEC 62262	IK06 (1J)
Vibration resistance	DIN EN 60068-2-6 Fc	10 g 10 frequency cycles, 1 octave/minute, in 3 axes
Shock resistance	DIN EN 60068-2-27 Ea	50 g 11 ms half-sine; 10 shocks each in every direction along the 3 coordinate axes
Continuous shock resistance	DIN EN 60068-2-29 Eb	40 g 6 ms half-sine; 4,000 shocks each in every direction along the 3 coordinate axes

R2D201



Radar area sensor

R2DBA00KG/US/CAN

Fast temperature changes	DIN EN 60068-2-14 Na	TA = -40°C; TB = 85°C; t1 = 30 min; t2 = < 30 s; 300 cycles
Salt spray test	DIN EN 60068-2-11 Ka	8 test cycles
Electrical safety	DIN EN 61010-2-201	electric shock / electrical supply only via SELV/PELV circuits
MTTF [years]		56
UL approval	Ta	-40...65 °C
	File number UL	E205959

Mechanical data

Weight [g]	428.3
Housing	rectangular
Mounting	flush mountable
Dimensions [mm]	80 x 80 x 45
Material	housing: PA; radome: PEI; sealing: HNBR

Displays / operating elements

Display	Power	1x LED, green
	errors	1x LED, red

Remarks

Pack quantity	1 pcs.
---------------	--------

Electrical connection

Connector: 1 x M12; coding: A

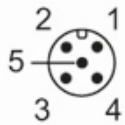

- 1: screen
- 2: Operating voltage
- 3: GND
- 4: CAN-H
- 5: CAN-L

R2D201



Radar area sensor

R2DBA00KG/US/CAN

Other data		
Operating mode	standard	Long range, high velocity
max. distance	0.1...20 m	0.25...35 m
distance resolution	100 mm	350 mm
horizontal angular resolution (azimuth)	10 °	10 °
distance accuracy	± 5 mm	± 15 mm
max. velocity	± 6 m/s	± 15 m/s
velocity resolution	± 0.20 m/s	± 0.38 m/s
speed accuracy	± 0.01 m/s	± 0.04 m/s
Sampling rate	20 Hz	20 Hz
Distance	based on E23013	
Resolution	for the detection of two objects of the same size	
Accuracy	for a strong, point-shaped target	

Diagrams and graphs

Monitoring range

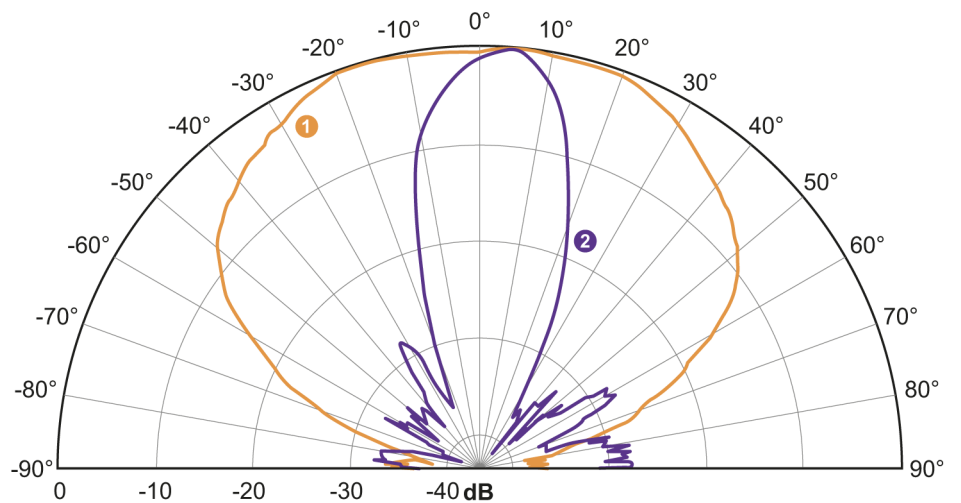

- 1: azimuth
- 2: elevation

conditions

Reflector: 4.3" Trihedral Corner Reflector (SAJ043-S1)

RCS: 10 dBm²

Distance: 5 m

operating frequency: 79 GHz