

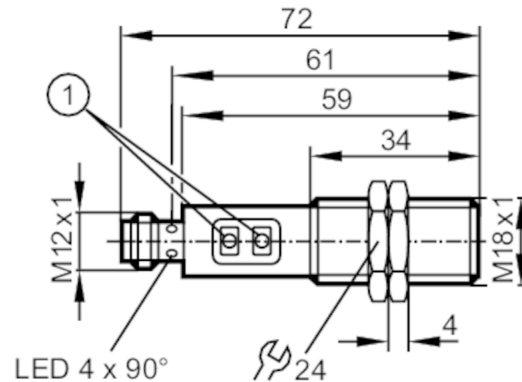

Diffuse reflection sensors with background suppression

OGH-FNKG/US100



1 Programming buttons



Product characteristics

| | |
|---------------|---------------|
| Type of light | red light |
| Housing | Threaded type |

Application

| | |
|--------------------|---------------------------|
| System | Background suppression |
| Function principle | Diffuse reflection sensor |

Electrical data

| | |
|-----------------------------|------------|
| Operating voltage [V] | 10...36 DC |
| Current consumption [mA] | 25 |
| Protection class | II |
| Reverse polarity protection | yes |
| Type of light | red light |
| Wave length [nm] | 624 |

Outputs

| | |
|--|---------------------------------------|
| Electrical design | NPN |
| Output function | light-on/dark-on mode; (programmable) |
| Max. voltage drop switching output DC [V] | 2.5 |
| Permanent current rating of switching output DC [mA] | 150; (200 (...60 °C)) |
| Switching frequency DC [Hz] | 1000 |
| Short-circuit protection | yes |
| Type of short-circuit protection | yes (non-latching) |
| Overload protection | yes |

Monitoring range

| | |
|-------------------------------|---|
| Range [mm] | 15...300; (white paper 200 x 200 mm 90 % remission) |
| Factory setting | light-on mode |
| Range adjustable | yes |
| Max. light spot diameter [mm] | 25 |

OGH502



Diffuse reflection sensors with background suppression

OGH-FNKG/US100

| | |
|----------------------------------|------------------|
| Light spot dimensions refer to | at maximum range |
| Background suppression available | yes |

Operating conditions

| | |
|--------------------------|----------|
| Ambient temperature [°C] | -25...80 |
| Protection | IP 67 |

Tests / approvals

| | |
|--------------|--------------|
| EMC | EN 60947-5-2 |
| MTTF [years] | 368 |

Mechanical data

| | |
|--------------------|--|
| Weight [g] | 61.7 |
| Housing | Threaded type |
| Dimensions [mm] | M18 x 1 / L = 72 |
| Thread designation | M18 x 1 |
| Material | stainless steel (1.4404 / 316L); PA; LCP; EPDM; TPU (urethane) |
| Lens material | PMMA |

Displays / operating elements

| | | |
|---------|------------------|-----------------|
| Display | Switching status | 1 x LED, yellow |
|---------|------------------|-----------------|

Accessories

| | |
|----------------|--------------|
| Items supplied | lock nuts: 2 |
|----------------|--------------|

Remarks

| | |
|---------------|---------------------------------|
| Remarks | cULus - Class 2 source required |
| Pack quantity | 1 pcs. |

Electrical connection

Connector: 1 x M12; coding: A





Diffuse reflection sensors with background suppression

OGH-FNKG/US100

Connection

