

# OGD250

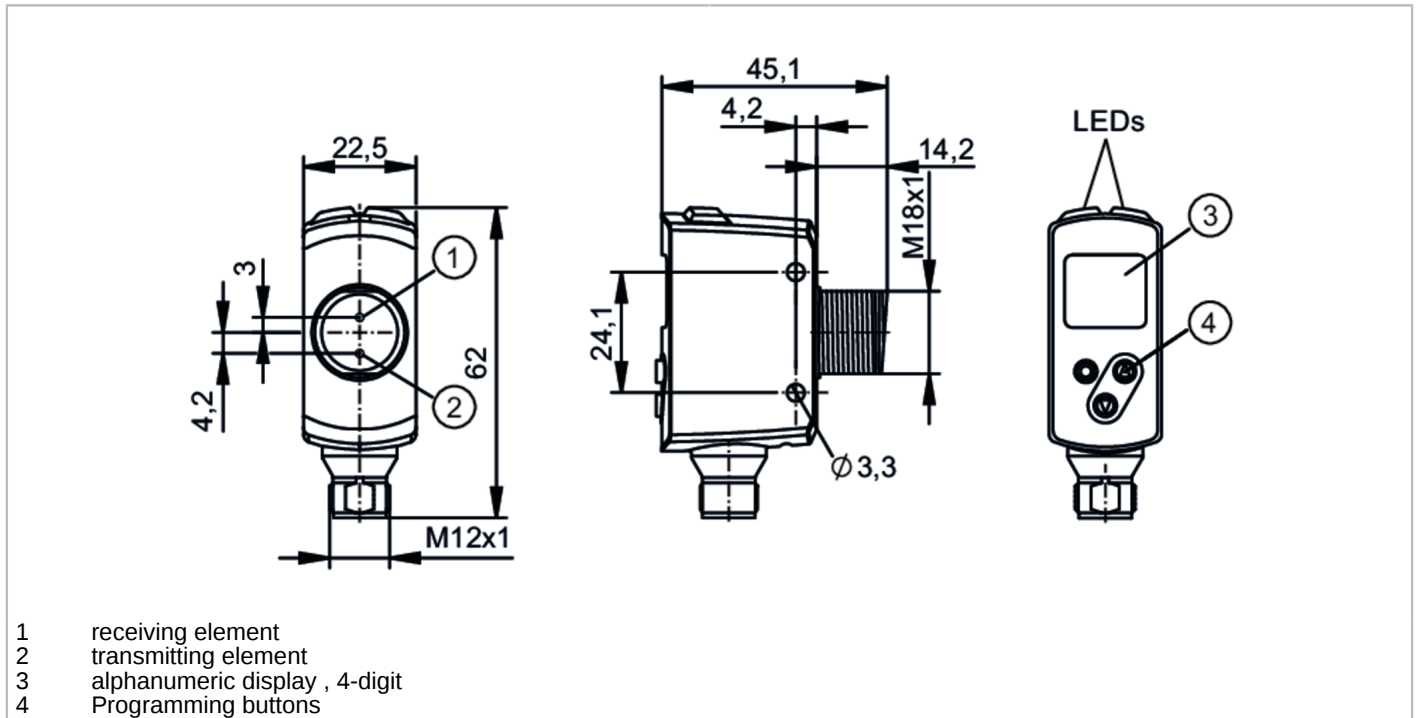

## Laser distance sensor

OGDLFCKG/IO-LINK/US



### Product characteristics

Type of light	red light
Laser protection class	1
Housing	rectangular with M18 thread

### Electrical data

Operating voltage	[V]	10...30 DC; (cULus - Class 2 source required)
Current consumption	[mA]	45; (24 V)
Protection class		III
Reverse polarity protection		yes
Type of light		red light
Wave length	[nm]	650

### Inputs

Inputs	Laser On/ Off
--------	---------------

### Outputs

Electrical design	PNP/NPN; (configurable)
Output function	2 x normally open / normally closed; (configurable)
Max. current load per output	[mA] 100
Short-circuit protection	yes
Type of short-circuit protection	yes (non-latching)
Overload protection	yes

### Operating mode: FINE

Switching frequency DC	[Hz]	20
------------------------	------	----



## Laser distance sensor

OGDLFCKG/IO-LINK/US

Operating mode: STD	
Switching frequency DC [Hz]	40
Operating mode: FAST	
Switching frequency DC [Hz]	60
<b>Monitoring range</b>	
Max. light spot diameter [mm]	5
Light spot dimensions refer to	at maximum range
Background suppression [m]	< 20
<b>Measuring/setting range</b>	
Setting range object reflectivity [%]	6...900; (reflectivity; 6 % black paper; 100 % white paper)
Operating mode: FINE	
Measuring range [m]	0.05...2
Sampling rate [Hz]	60
Operating mode: STD	
Measuring range [m]	0.05...2
Sampling rate [Hz]	120
Operating mode: FAST	
Measuring range [m]	0.05...1
Sampling rate [Hz]	180
<b>Software / programming</b>	
Parameter setting options	Distance / reflectivity; hysteresis / window; sequence modulation to avoid mutual interference between up to 5 similar devices; sensitivity
<b>Interfaces</b>	
Communication interface	IO-Link
Transmission type	COM2 (38,4 kBaud)
IO-Link revision	1.1.3
SDCI standard	IEC 61131-9
Profiles	Common - I&D Identification and Diagnosis Function Locator Function ProductURI
SIO mode	yes
Required master port class	A
Min. process cycle time [ms]	5
IO-Link process data (cyclical)	<b>Function</b> <b>bit length</b> Distance            16 reflectivity         16 device status       4 binary switching information    2
IO-Link functions (acyclical)	application specific tag; operating hours counter; switching cycles counter
Supported DeviceIDs	<b>Type of operation</b> <b>DeviceID</b> default                    1581
Note	For further information please see the IODD PDF file at "Downloads"

# OGD250



## Laser distance sensor

OGDLFCKG/IO-LINK/US

Operating conditions	
Ambient temperature [°C]	-25...55
Note on ambient temperature	In ambient temperatures < -10 °C a warm-up time is necessary. Laser is off.
Storage temperature [°C]	-30...80
Protection	IP 65; IP 67

Tests / approvals		
EMC	EN 60947-5-2	
Laser protection class	1	
Notes on laser protection	Caution: laser class:	Laser light 1
		EN / IEC60825-1:2007
		EN / IEC60825-1:2014
		Complies with 21 CFR 1040.10 except for conformance with IEC 60825-1 Ed. 3, as described in Laser Notice No. 56, dated May 8, 2019.
MTTF [years]	319	
UL approval	Ta	-25...60 °C
	Enclosure type	Type 1
	voltage supply	Class 2
	File number UL	E174191

Mechanical data	
Weight [g]	52.06
Housing	rectangular with M18 thread
Dimensions [mm]	62 x 22.5 x 45.1
Thread designation	M18 x 1
Material	housing: PPSU; ABS; PMMA; PBT / PC; EPDM; front lens: PMMA
Lens alignment	Side sensing

Displays / operating elements		
Display	Switching status	2 x LED, yellow 1 x alphanumeric display, 4-digit
	Operating elements	3 pushbuttons

Accessories	
Items supplied	lock nuts: 2

Remarks	
Pack quantity	1 pcs.

### Electrical connection - plug

Connector: 1 x M12; coding: A

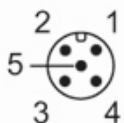

# OGD250



## Laser distance sensor

OGDLFCKG/IO-LINK/US

### Connection

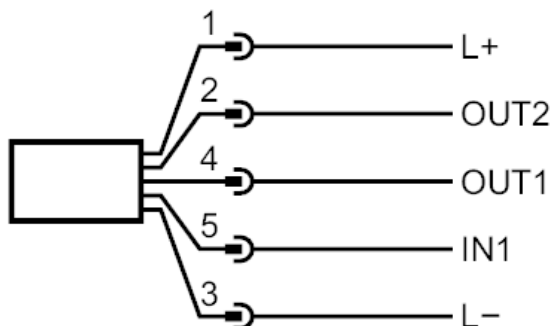

1 L+	
2 OUT 2	Switching output
3 L-	
4 OUT 1	switching output or IO-Link
5 IN 1	Laser On/ Off

# OGD250



## Laser distance sensor

OGDLFCKG/IO-LINK/US

Other data		
Parameter	Setting range	Factory setting
SEL1	Dist / Refl	Dist
OU1	Hno, Hnc, Fno, Fnc.OFF	Hno
SP1 [mm]	50...2000	1000
SP1 [%]	6...900	10
nSP1 [mm]	50...2000	900
FSP1 [cm]	50...2000	1100
SF1 [mm]	10...500	50
bSP1 [%]	6...900	40
dSP1 [%]	6...900	30
SF1 [%]	1...100	10
dS1 [s]	0...0.1...5	0
dr1 [s]	0...0.1...5	0
SEL2	Dist / Refl	Dist
OU2	Hno, Hnc, Fno, Fnc, OFF	Hno
SP2 [mm]	50...2000	2000
SP2 [%]	6...900	6
nSP2 [mm]	50...2000	1800
FSP2 [mm]	50...2000	2000
SF2 [mm]	10...500	50
bSP2 [%]	6...900	20
dSP2 [%]	6...900	10
SF2 [%]	1...100	10
dS2 [s]	0...0.01...5	0
dr2 [s]	0...0.01...5	0
dSO [s]	0...0.01...5	0.1
diS	On / OFF	On
colr	rEd; GrEn; r1ou; G1ou; r2ou; G2ou; r-12; G-ou	G1ou
P-n	PNP,NPN	PNP
OPEr (operating mode)	FINE,STD, FAST	FINE
SEQ	auto; S1...S5	auto
CMPT	250 / 580 / 581 / 585 / 586 / 592 / 593 / 596 / 597 / 582 / 583	250

# OGD250



## Laser distance sensor

OGDLFCKG/IO-LINK/US

### repeatability: $\pm 3 \sigma$

Operating mode: FINE	Repeatability of the measured values	
distance	white (90 % remission)	black (6 % remission)
50...300	$\pm 2$ mm	$\pm 3$ mm
300...500	$\pm 2$ mm	$\pm 3$ mm
500...1000	$\pm 3$ mm	$\pm 5$ mm
1000...2000	$\pm 5$ mm	$\pm 8$ mm
Operating mode: STD	Repeatability of the measured values	
50...300	$\pm 4$ mm	$\pm 5$ mm
300...500	$\pm 4$ mm	$\pm 5$ mm
500...1000	$\pm 4$ mm	$\pm 5$ mm
1000...2000	$\pm 8$ mm	$\pm 15$ mm
Operating mode: FAST	Repeatability of the measured values	
50...300	$\pm 5$ mm	$\pm 8$ mm
300...500	$\pm 5$ mm	$\pm 8$ mm
500...1000	$\pm 5$ mm	$\pm 19$ mm
1000...2000	$\pm 10$ mm	-
Operating mode: FINE / STD / FAST	Repeatability of the measured values	
reflectivity		
6 %	$\pm 3$ %	
50 %	$\pm 5$ %	
90 %	$\pm 8$ %	

The values apply at

Extraneous light on the object	< 10 klx
constant ambient conditions	23 °C / 960 hPa
minimum power-on time in minutes	15



## Laser distance sensor

OGDLFCKG/IO-LINK/US

### Diagrams and graphs

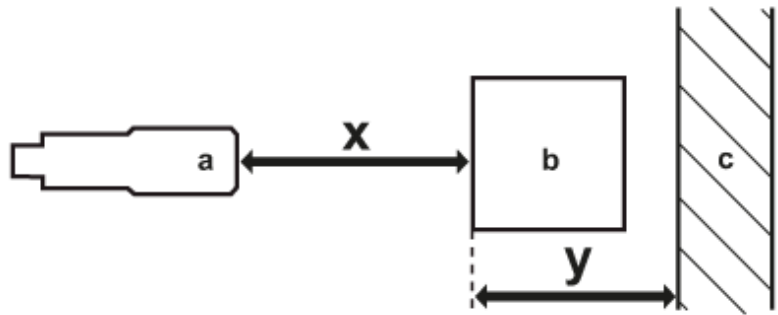

- a: sensor
- b: object
- c: background
- x: distance sensor/object [mm]
- y: min. distance object/background [mm]

Hysteresis graph for distance measurement / operating mode: FINE

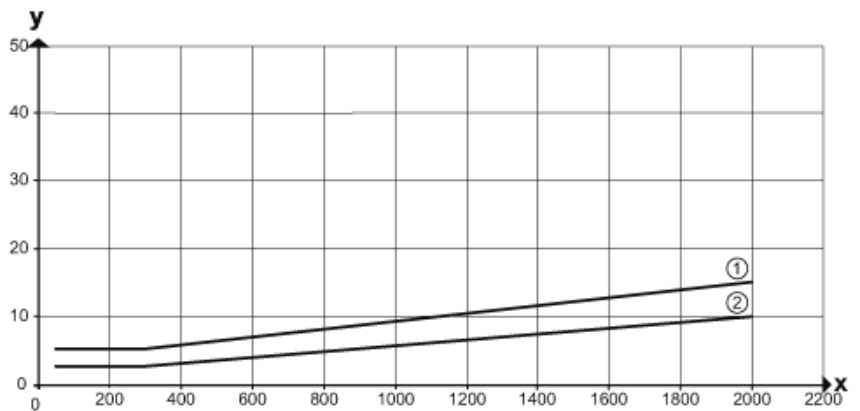

- 1: Background any (6...90 % remission)
- 2: Background white (90 % remission)



## Laser distance sensor

OGDLFCKG/IO-LINK/US

Hysteresis graph for distance measurement / operating mode: STD

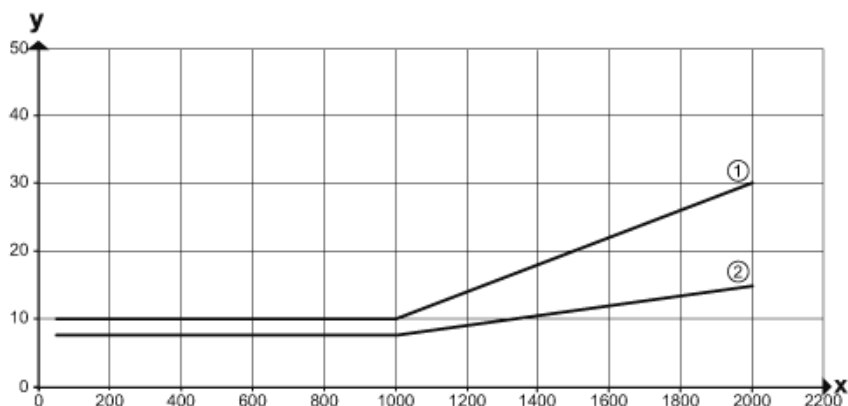

1: Background any (6...90 % remission)

2: Background white (90 % remission)

Hysteresis graph for distance measurement / operating mode: FAST

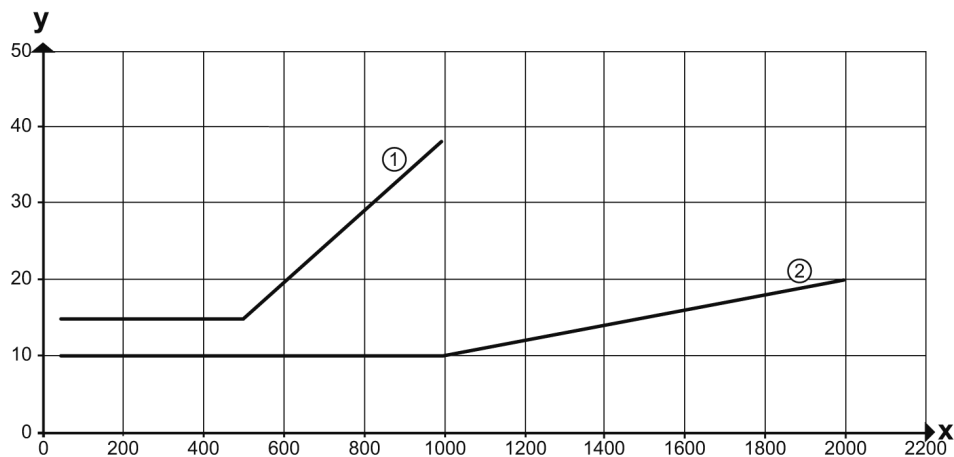

1: Background any (6...90 % remission)

2: Background white (90 % remission)

# OGD250

## Laser distance sensor

OGDLFCKG/IO-LINK/US

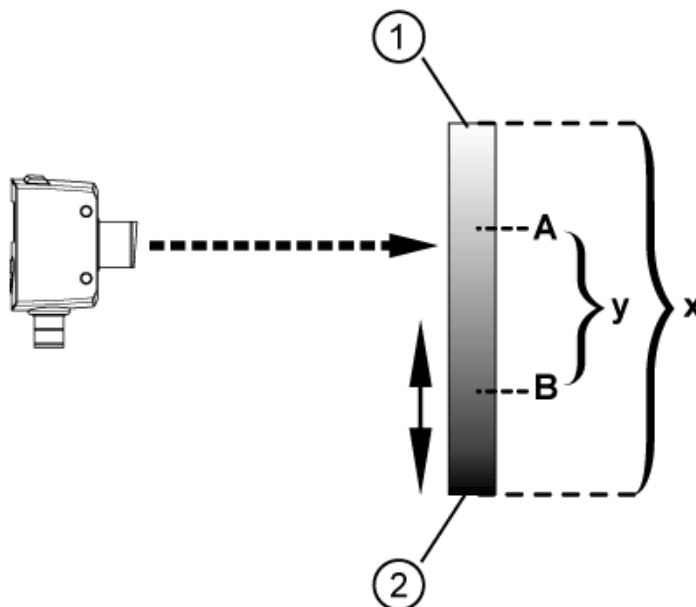

- 1: bright
- 2: dark
- A: Set point
- B: Reset point
- x: object brightness ( Object reflectivity )
- y: min. reflectivity difference to be detected safely

Hysteresis curve for object reflectivity

