

OBF501

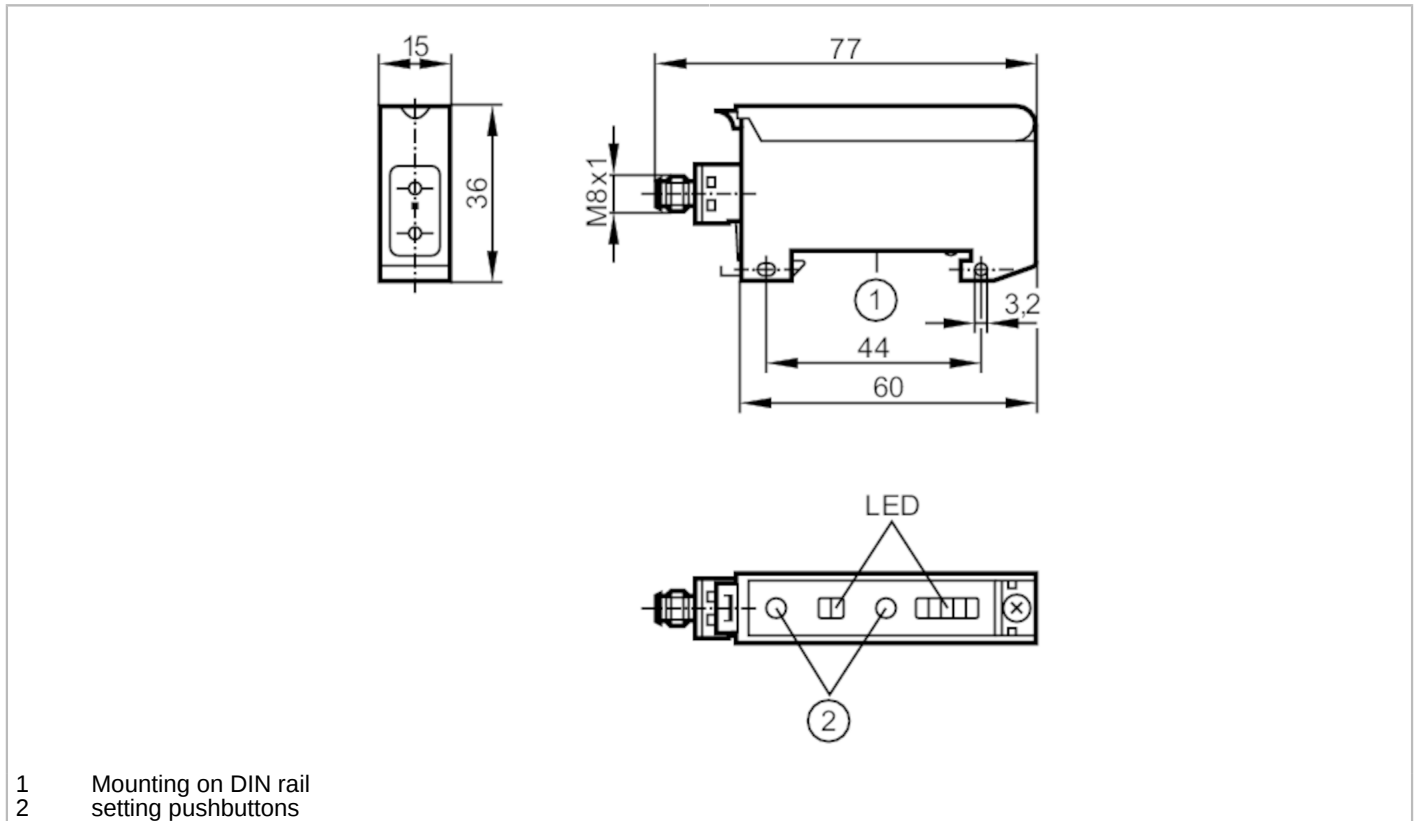

Fiber-optic amplifier

OBF-FAKG/TIAS



Product characteristics	
Type of light	red light
Housing	rectangular
Application	
System	Function check output
Design	Fiber optic amplifiers for acrylic fibers, Type OBF
Electrical data	
Operating voltage [V]	10...30 DC
Current consumption [mA]	< 50
Protection class	III
Reverse polarity protection	yes
Type of light	red light
Wave length [nm]	630
Outputs	
Electrical design	PNP/NPN; (Automatic load detection PNP/NPN)
Output function	light-on/dark-on mode; (programmable)
Max. voltage drop switching output DC [V]	2.5
Function check output	yes
Max. voltage drop of function check output [V]	2.5

OBF501



Fiber-optic amplifier

OBF-FAKG/TIAS

Max. current load for function check output [mA]	10
Permanent current rating of switching output DC [mA]	100
Switching frequency DC [Hz]	3000
Short-circuit protection	yes
Type of short-circuit protection	yes (non-latching)
Overload protection	yes
Time function [s]	0.001...0.09

Monitoring range

Range [m]	0...2; (Through-beam sensor)
Range [mm]	0...100; (Diffuse reflection sensor)
Range adjustable	yes

Operating conditions

Ambient temperature [°C]	-25...60
Protection	IP 65

Tests / approvals

EMC	EN 60947-5-2
MTTF [years]	806

Mechanical data

Weight [g]	48.35
Housing	rectangular
Type of mounting	Mounting on DIN rail; (TH35 (EN 60715))
Dimensions [mm]	36 x 15 x 60
Number of channels	1
Material	housing: PPE modified

Displays / operating elements

Display	Switching status	1 x LED, yellow
	Power	1 x LED, green
	Unsafe zone	1 x LED, red
	Excess gain	4 x LED, green

Remarks

Remarks	light-on mode corresponds to the NC output function for through-beam fibers corresponds to the NO output function for diffuse-reflection fibers dark-on mode corresponds to the NO output function for through-beam fibers corresponds to the NC output function for diffuse-reflection fiber optics cULus - Class 2 source required
Pack quantity	1 pcs.

OBF501



Fiber-optic amplifier

OBF-FAKG/TIAS

Electrical connection

Connector: 1 x M8; coding: A



Connection

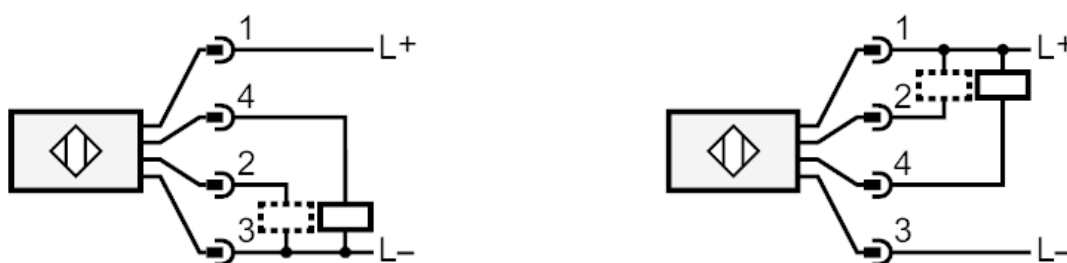

2 Function check output

Diagrams and graphs

excess gain graph

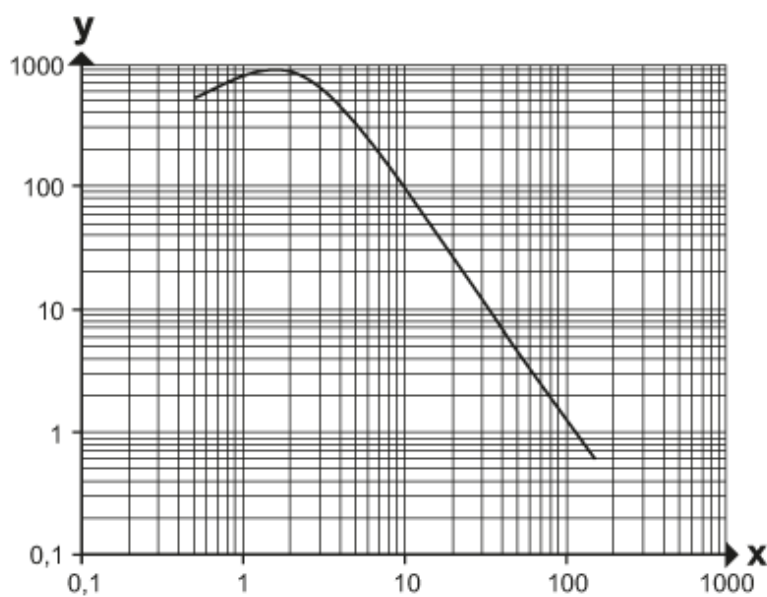

x: Abstand [mm]

y: Funktionsreservfaktor