

# O3D313

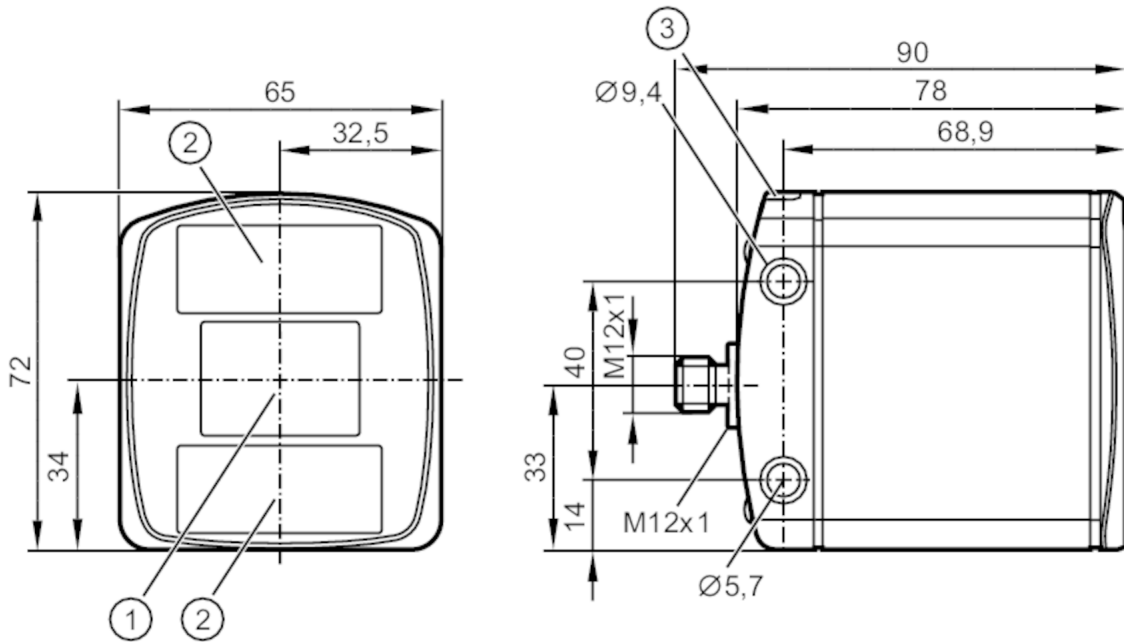

## ToF camera

O3DIRDKG/E1/GM/S/60



- 1 lens
- 2 Illumination unit
- 3 LED 2-color yellow/green



### Product characteristics

Type of light	Infrared light
Image resolution 3D [px]	352 x 264
Angle of aperture 3D [°]	60 x 45; (nominal value without lens distortion correction)
Image repetition frequency 3D [Hz]	25
Housing	rectangular

### Application

Application	Camera for the output of 3D image data
-------------	--

### Electrical data

Operating voltage [V]	20.4...28.8 DC; (EN 61131-2)
Current consumption [mA]	420; (maximum mean value: < 1600 mA)
Max. current consumption [mA]	2400; (peak current pulsed)
Power consumption [W]	10; (typical value)
Protection class	III
Overvoltage category	II
Type of light	Infrared light
Image sensor	PMD 3D ToF-Chip
Integrated lighting	infrared: 850 nm invisible radiation LED

### Inputs / outputs

Number of inputs and outputs	Number of digital inputs: 1; Number of digital outputs: 2
------------------------------	---

# O3D313



## ToF camera

O3DIRDKG/E1/GM/S/60

Inputs		
Trigger		external; 24 V PNP/NPN (IEC 61131-2 Typ 3)
Number of digital inputs		1
Outputs		
Number of digital outputs		2; (configurable)
Output function		24 V PNP/NPN; (EN 61131-2)
Max. voltage drop switching output DC	[V]	1
Max. current load per output	[mA]	100
Short-circuit protection		yes
Type of short-circuit protection		yes (non-latching)
Overload protection		yes
Monitoring range		
Operating distance	[mm]	300...8000
Note on operating distance		object size: 200 x 200 mm reflectivity: 18 %
Image resolution 3D	[px]	352 x 264
Angle of aperture 3D	[°]	60 x 45; (nominal value without lens distortion correction)
Image repetition frequency 3D	[Hz]	25
Software / programming		
Parameter setting options		via PC with ifm Vision Assistant or XML-RPC; software API for C, C++ and Halcon
Interfaces		
Communication interface		Ethernet
Ethernet		
Transmission standard		10Base-T; 100Base-TX
Transmission rate		10; 100
Protocol		TCP/IP
Factory settings		IP address: 192.168.0.69 subnet mask: 255.255.255.0 gateway IP address: 192.168.0.201
Usage type		Parameter setting; Data transmission
Operating conditions		
Ambient temperature	[°C]	-10...50
Storage temperature	[°C]	-40...85
Protection		IP 65; IP 67; IP 69K
Max. immunity to extraneous light	[klx]	8; (with reduced measuring accuracy and repeatability: < 100)
Tests / approvals		
EMC	DIN EN 61000-6-4	radiation of interference / industrial environments
	DIN EN 61000-6-2	noise immunity / industrial environments
Shock resistance	DIN EN 60068-2-27	50 g / (11 ms) not repetitive
	DIN EN 60068-2-27	40 g / (6 ms) repetitive

# O3D313



## ToF camera

O3DIRDKG/E1/GM/S/60

Vibration resistance	DIN EN 60068-2-6	2 g / (10...150 Hz)
	DIN EN 60068-2-64	2.3 g RMS / (10...500 Hz)
Photobiological safety	exempt group; (DIN EN 62471)	
Electrical safety	DIN EN 61010-2-201	electrical supply only via PELV circuits
MTTF [years]	45.02	

### Mechanical data

Weight [g]	1189	
Housing	rectangular	
Dimensions [mm]	72 x 65 x 78	
Material	housing: stainless steel (1.4404 / 316L); front lens: PMMA; Function display: PA	
Tightening torque [Nm]	< 0.8	

### Displays / operating elements

Display	Function	2 x LED, green Ethernet Power
	Switching status	2 x LED, yellow OUT 1 OUT 2

### Accessories

Items supplied	Protective covers
----------------	-------------------

### Remarks

Remarks	Repeatability and accuracy depend on the image settings and the environmental conditions. The data sheet values apply to typical settings and conditions.
Pack quantity	1 pcs.

### Electrical connection - Ethernet

Connector: 1 x M12; coding: D



1	TD +
2	RD +
3	TD -
4	RD -



## ToF camera

O3DIRDKG/E1/GM/S/60

### Electrical connection - Process connection

Connector: 1 x M12; coding: A

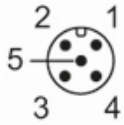

1	U+
2	trigger input
3	GND
4	Switching output 1 Ready
5	Switching output 2 Cascading

### Other data

#### Field of view size

Measuring range / distance [m]	without lens distortion correction		with lens distortion correction	
	Length [m]	Width [m]	Length [m]	Width [m]
0.50	0.40	0.56	0.37	0.50
1.00	0.80	1.13	0.75	1.00
2.00	1.60	2.26	1.50	2.00
3.00	2.40	3.39	2.25	3.00
4.00	3.20	4.52	3.00	4.00
5.00	4.00	5.65	3.75	5.00

#### repeatability of the distance measurement of an individual pixel

Measuring range / distance [m]	repeatability of the measured distance values on grey objects (18% reflectivity) [mm]	Accuracy [mm]
	typical value	typical value
0.3...1.0	± 8	± 7
1.0...3.0	± 12	± 7
3.0...5.0	± 20	± 10
5.0...7.0	± 30	± 15
7.0...8.0	± 50	± 20

measured in the center of the image at an ambient temperature of 20°C

The repeatability can be optimized with filter functions

Repeatability  $1 \sigma$

# O3D313



## ToF camera

O3DIRDKG/E1/GM/S/60

### Relative accuracy

Relative accuracy	± 4 mm
Temperature drift -10...+50 °C	0.2 mm/K
measured at a reflectivity of 18% to 90%	

### Parameter setting options

Parameter	Setting range	Factory setting
Exposure time [ms]	0.002...10	5
dynamic range	low; Normal operation ; high	Normal operation
filter	Time function:	
	mean value; adaptive exponential	disabled
	3D function:	
	mean value, median, bilateral function	disabled
Trigger	Continuous ; data interface; positive edge; negative edge; positive and negative edge	Continuous
Image repetition frequency [Hz]	0.02...25	5

### data format

data type	data value	Remarks
Distance [mm]	0...65535 uint16	radial distance
Cartesian coordinates x,y,z [mm]	-32767...32767 int16	x,y: lateral position z: vertical distance
amplitude	0...65535 uint16	object brightness