

LMC100

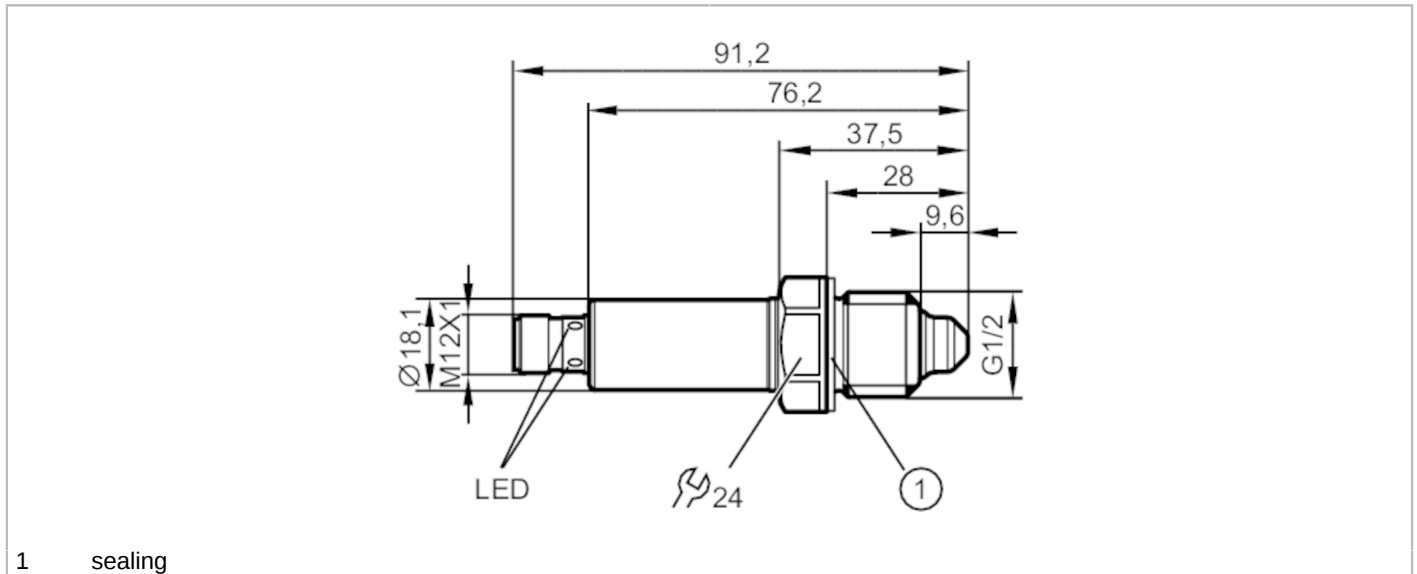

Sensor for point level detection

LMFCE-B12E-QSKG-0/US



Product characteristics

Number of inputs and outputs	Number of digital outputs: 2
Factory setting	water; water-based media
Process connection	G 1/2 external thread

Application

System	gold-plated contacts
Media	water; water-based media; oils; oil-based media; Coolants; powder
Cannot be used for	See the operating instructions, chapter "Function and features".
Medium temperature [°C]	-25...100
Probe length [mm]	28
Tank pressure	-1...40 bar -0.1...4 MPa
MAWP (for applications according to CRN) [bar]	40

Oil

Medium temperature [°C]	-25...100
-------------------------	-----------

Electrical data

Operating voltage [V]	18...30 DC
Current consumption [mA]	< 35
Protection class	III
Reverse polarity protection	yes

Inputs / outputs

Number of inputs and outputs	Number of digital outputs: 2
------------------------------	------------------------------

Outputs

Total number of outputs	2
Output signal	switching signal; IO-Link
Electrical design	PNP/NPN
Number of digital outputs	2

LMC100



Sensor for point level detection

LMFCE-B12E-QSKG-0/US

Output function	normally open / closed; (configurable)
Max. voltage drop switching output DC [V]	2.5
Permanent current rating of switching output DC [mA]	50; (100 (...60 °C))
Short-circuit protection	yes
Type of short-circuit protection	thermal, pulsed
Overload protection	yes

Measuring/setting range

Factory setting	water; water-based media
-----------------	--------------------------

Reaction times

Response time [s]	< 0.5
-------------------	-------

Interfaces

Communication interface	IO-Link	
Transmission type	COM2 (38,4 kBaud)	
IO-Link revision	1.1	
SDCI standard	IEC 61131-9	
Profiles	Smart Sensor - SSP 0 Generic Profiled Sensor	
	Function Device identification	
	Function Process data variable	
	Function Device diagnosis	
SIO mode	yes	
Required master port class	A	
Process data analog	1	
Process data binary	2	
Min. process cycle time [ms]	3.2	
Supported DeviceIDs	Type of operation default	DeviceID 674

Operating conditions

Ambient temperature [°C]	-25...85
Storage temperature [°C]	-40...85
Protection	IP 68; IP 69K; (7 days / 1 m water depth / 0.1 bar: IP 68)

Tests / approvals

EMC	DIN EN 61000-6-2	
	DIN EN 61000-6-3	: closed tanks
	DIN EN 61000-6-4	: open tanks
Shock resistance	DIN EN 60068-2-27	50 g (11 ms)
Vibration resistance	DIN EN 60068-2-6	20 g (10...2000 Hz)
MTTF [years]		534
UL approval	UL approval number	H003

Mechanical data

Weight [g]	117.45
Dimensions [mm]	Ø 18.1 / L = 76.2
Material	stainless steel (1.4404 / 316L); PEEK; PEI; FKM
Materials (wetted parts)	stainless steel (1.4404 / 316L); PEEK; FKM

LMC100



Sensor for point level detection

LMFCE-B12E-QSKG-0/US

Process connection G 1/2 external thread

Displays / operating elements

Display	Switching status	LED, yellow
	operating status	LED, green

Accessories

Items supplied sealing 1 x (26,5 x 21,3 x 1,5 mm), Centellen

Remarks

Pack quantity 1 pcs.

Electrical connection

Connector: 1 x M12; coding: A; Contacts: gold-plated



Connection

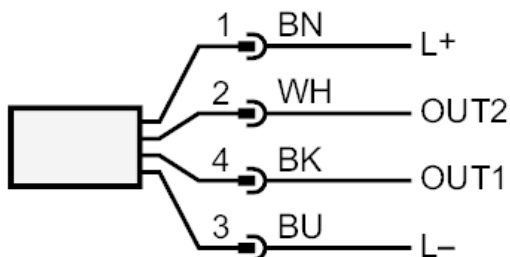

OUT1: Switching output IO-Link
OUT2: Switching output
Colors to DIN EN 60947-5-2
Core colors :
BK = black
BN = brown
BU = blue
WH = white