

IG511A

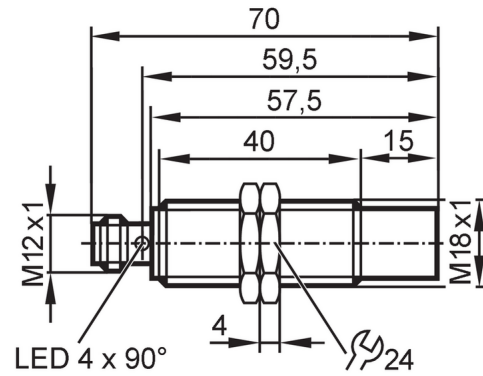

Inductive full-metal sensor

IGK3012-BPKG/AM/P/US104/3G/3D



Product characteristics	
Electrical design	PNP
Output function	normally open
Sensing range [mm]	12
Housing	Threaded type
Dimensions [mm]	M18 x 1 / L = 70
Application	
System	gold-plated contacts; Increased sensing range; Full-metal housing
Pressure rating	100 bar / 10 MPa
Note on pressure rating	sensing face
Electrical data	
Operating voltage [V]	10...30 DC
Current consumption [mA]	< 25
Protection class	III
Reverse polarity protection	yes
Outputs	
Electrical design	PNP
Output function	normally open
Max. voltage drop switching output DC [V]	2.5
Permanent current rating of switching output DC [mA]	100
Switching frequency DC [Hz]	500
Short-circuit protection	yes
Overload protection	yes
Monitoring range	
Sensing range [mm]	12
Real sensing range Sr [mm]	12 ± 10 %
Operating distance [mm]	0...9.72
Increased sensing range	yes
Accuracy / deviations	
Correction factor	steel: 1 / stainless steel: 1 / brass: 0.9 / aluminum: 0.8 / copper: 0.5

IG511A



Inductive full-metal sensor

IGK3012-BPKG/AM/P/US104/3G/3D

Hysteresis	[% of Sr]	1...20
Switch-point drift	[% of Sr]	-10...10

Operating conditions

Ambient temperature	[°C]	-40...60
Protection		IP 67; (when used outside the hazardous area: IP 65, IP 67, IP 68, IP 69K)

Tests / approvals

Approval	BVS 20 ATEX E 055 X; IECEx BVS 20.0042 X	
ATEX marking	II 3G Ex ec IIC T4 Gc	
	II 3D Ex tc IIIC T95°C Dc	
EMC	EN 61000-4-2 ESD	4 kV CD / 8 kV AD
	EN 61000-4-3 HF radiated	10 V/m
	EN 61000-4-4 Burst	2 kV
	EN 61000-4-6 HF conducted	10 V
	EN 55011	class B
Impact resistance	EN 60068-2-75 Ehc	1 J
Vibration resistance	EN 60068-2-6 Fc	20 g (10...3000 Hz) / 50 sweep cycles per frequency; 1 octave per minute in 3 axes
Shock resistance	EN 60068-2-27 Ea	100 g 11 ms half-sine; 3 shocks each in every direction of the 3 coordinate axes
Continuous shock resistance	EN 60068-2-27 Ea	40 g 6 ms; 4000 shocks each in every direction of the 3 coordinate axes
Fast temperature changes	EN 60068-2-14 Na	TA = -40°C; TB = 85°C; t1 = 30 min; t2 = 10 s 50 cycles
Salt spray test	EN 60068-2-52 Kb	severity level 5 (4 test cycles)
MTTF	[years]	1352

Mechanical data

Weight	[g]	79.5
Housing		Threaded type
Mounting		non-flush mountable
Dimensions	[mm]	M18 x 1 / L = 70
Thread designation		M18 x 1
Material		stainless steel (1.4404 / 316L); PEI; lock nuts: brass white bronze coated
Tightening torque	[Nm]	50
Full-metal housing		yes

Displays / operating elements

Display	Switching status	4 x 90° LED, yellow
---------	------------------	---------------------

Accessories

Items supplied	lock nuts: 2	
----------------	--------------	--

Remarks

Remarks	To maintain the EMC data: Equalize potential by connecting the sensor housing to the machine earth.	
Pack quantity	1 pcs.	

IG511A



Inductive full-metal sensor

IGK3012-BPKG/AM/P/US104/3G/3D

Electrical connection - plug

Connector: 1 x M12; coding: A; Contacts: gold-plated

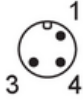

Connection

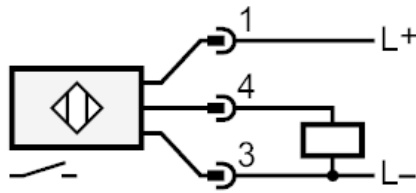

Diagrams and graphs

