

IF5647

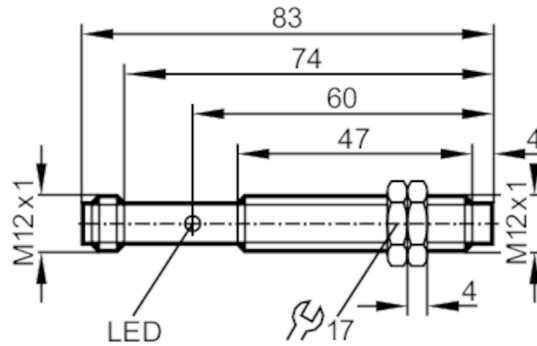

Inductive sensor

IFA2004-FRKG/US-100-IRF



Product characteristics

Electrical design	PNP/NPN
Output function	normally open / closed; (selectable)
Sensing range [mm]	4
Housing	Threaded type
Dimensions [mm]	M12 x 1 / L = 83

Electrical data

Operating voltage [V]	10...55 DC
Protection class	III
Reverse polarity protection	yes

Outputs

Electrical design	PNP/NPN
Output function	normally open / closed; (selectable)
Max. voltage drop switching output DC [V]	4.6
Minimum load current [mA]	4
Max. leakage current [mA]	0.5
Permanent current rating of switching output DC [mA]	300
Switching frequency DC [Hz]	1500
Short-circuit protection	yes
Type of short-circuit protection	yes (non-latching)
Overload protection	yes

Monitoring range

Sensing range [mm]	4
Real sensing range Sr [mm]	4 ± 10 %
Operating distance [mm]	0...3.25

Accuracy / deviations

Hysteresis [% of Sr]	1...15
Switch-point drift [% of Sr]	-10...10

IF5647



Inductive sensor

IFA2004-FRKG/US-100-IRF

Operating conditions

Ambient temperature	[°C]	-25...80
Protection		IP 67

Tests / approvals

EMC	EN 60947-5-2	
	EN 55011	class B
MTTF	[years]	1815
UL approval	Ta	0...40 °C
	Enclosure type	Type 1
	File number UL	E174191

Mechanical data

Weight	[g]	32
Housing		Threaded type
Mounting		non-flush mountable
Dimensions	[mm]	M12 x 1 / L = 83
Thread designation		M12 x 1
Material		brass white bronze coated; sensing face: PC

Displays / operating elements

Display	Switching status	1 x LED, yellow
---------	------------------	-----------------

Accessories

Items supplied		lock nuts: 2
----------------	--	--------------

Remarks

Pack quantity		1 pcs.
---------------	--	--------

Electrical connection - plug

Connector: 1 x M12; coding: A

