

E40582

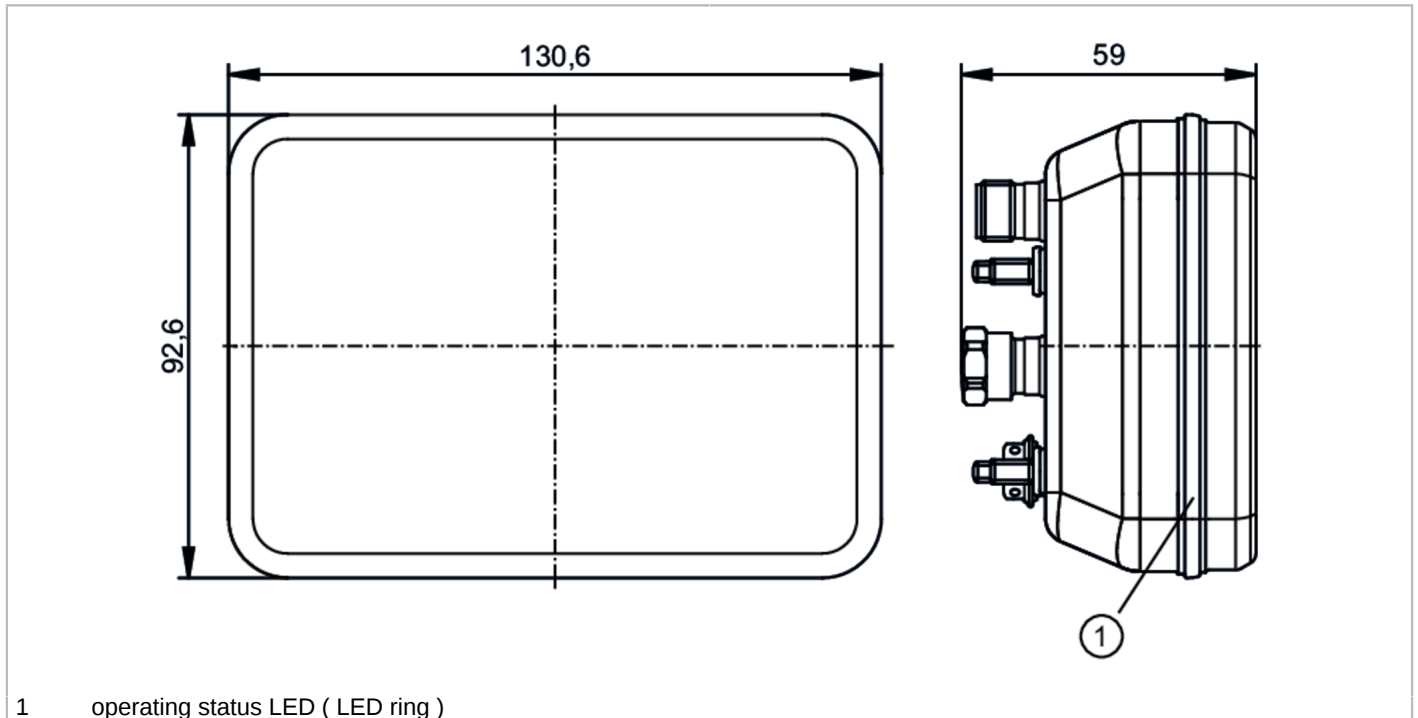

Electronic unit for SMF_x5x magnetic-inductive flow sensor

MEASURING CONVERTER NO DISPLAY



Application		
System		gold-plated contacts
Application		food and beverage industry
Electrical data		
Operating voltage	[V]	18...32 DC
Current consumption	[mA]	250; (24V)
Protection class		III
Reverse polarity protection		yes
Power-on delay time	[s]	< 5
Inputs / outputs		
Total number of inputs and outputs		2
Inputs		
Inputs	OUT2	external totalizer reset
Outputs		
Total number of outputs		2
Output signal	OUT1	pulse signal; totalizer switching signal; diagnostic signal; IO-Link
	OUT2	analog signal; pulse signal; totalizer switching signal; diagnostic signal
Electrical design		PNP/NPN
Pulse output		flow rate meter
Short-circuit protection		yes
Type of short-circuit protection		yes (non-latching)
Overload protection		yes

E40582



Electronic unit for SMF_x5x magnetic-inductive flow sensor

MEASURING CONVERTER NO DISPLAY

Analog		
Number of analog outputs		1
Analog current output	[mA]	4...20; (skalierbar)
Max. load	[Ω]	500
Resolution of analog output		0.38 μA
Digital		
Number of digital outputs		2
Max. voltage drop switching output DC	[V]	2
Permanent current rating of switching output DC	[mA]	100
Switching frequency DC	[Hz]	0...10000
Software / programming		
Diagnostic functions		direction of flow detection; liquid detection
Interfaces		
Communication interface		IO-Link
Transmission type		COM3 (230,4 kBaud)
IO-Link revision		1.1.3
SDCI standard		IEC 61131-9
Profiles	Common - I&D Smart Sensor - SSP 4.3.4	Identification and Diagnosis Measuring and Switching Sensor, floating point, 4 channel
SIO mode		yes
Required master port class		A
Process data analog		6
Process data binary		8
Min. process cycle time	[ms]	1.9
IO-Link process data (cyclical)	Function	bit length
	totalizer	32
	flow	32
	temperature	32
	conductivity	32
	status	4
	binary switching information	8
IO-Link functions (acyclical)		direction of flow detection; totalizer; memory; operating hours counter; internal temperature; simulation function
Operating conditions		
Ambient temperature	-20...65 °C	-4...149 °F
Storage temperature	-20...80 °C	-4...176 °F
Protection		IP 67; IP 69
Tests / approvals		
EMC	DIN 61326-1	
Shock resistance	DIN IEC 68-2-27	20 g (18ms)
Vibration resistance	DIN IEC 68-2-6	5 g (10...2000Hz)
Mechanical data		
Weight	[g]	973

E40582



Electronic unit for SMF_x5x magnetic-inductive flow sensor

MEASURING CONVERTER NO DISPLAY

Housing	rectangular
Dimensions [mm]	92.6 x 130.6 x 59
Material	electronics: stainless steel (1.4404 / 316L); LED ring: PP

Displays / operating elements

Display	operating status	LED ring, three-color
---------	------------------	-----------------------

Accessories

Items supplied	replacement electronics: 1 x (92,6 x 130,6 x 59 mm), for SMF _x 5x Hexagon nuts: 4 x M5
----------------	--

Remarks

Pack quantity	1 pcs.
---------------	--------

Electrical connection

Connector: 1 x M12; coding: A; Contacts: gold-plated



Connection

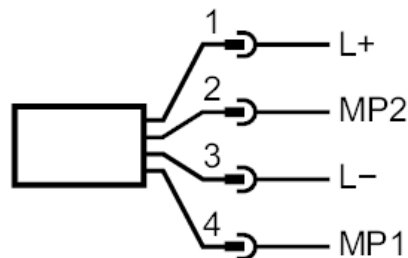

1:	L+
2:	OUT MP2, DO, AO, Reset
3:	L-
4:	OUT1 MP1, DO, IO-Link