

E30513

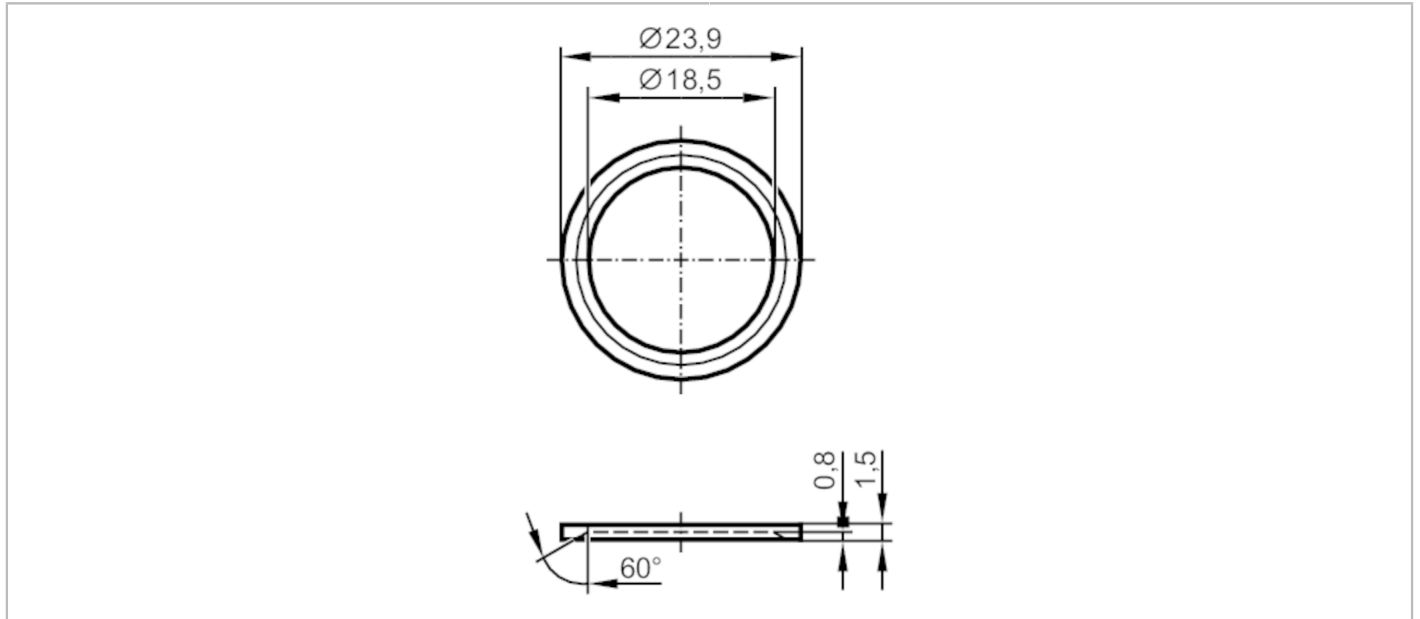

Gasket

SEAL RING FFKM G1/2



Application	
Design	for units with process connection G ½
Operating conditions	
Ambient temperature [°C]	-5...200
Tests / approvals	
Standard	DIN EN ISO 1179-2
Mechanical data	
Weight [g]	2.05
Inside diameter [mm]	18.5
Outer diameter [mm]	23.9
Material	FFKM
Remarks	
Pack quantity	1 pcs.