

E30130



Welding adapter for process sensors

WELDING ADAPT D50/G1 LEAK PORT

recommended for wall thickness ≤ 3 mm. There are more suitable welding adapters for thicker walls.

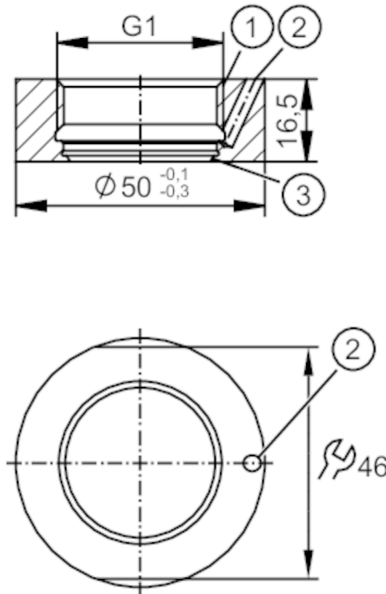

- 1 G1 Internal thread Aseptoflex Vario
- 2 Leakage port
- 3 sealing area



ACS CRN EC 1935/2004 EHEDG Certified FCM FDA

Application

Design	with leakage port (3A)
Installation	recommended for wall thickness ≤ 3 mm
Pressure rating	50 bar 5 MPa
Note on pressure rating	for the connection sensor - adapter

Tests / approvals

Pressure equipment directive	A possible classification to PED depends on the application and has to be carried out by the user / operator.
Safety instructions	The compatibility between medium and product material has to be checked in all applications.

Mechanical data

Weight	[g]	186
Materials (wetted parts)	stainless steel (1.4435 / 316L) surface characteristics: Ra < 0,4 μ m / Rz = 4 μ m	
Sensor connection	G 1 Internal thread Aseptoflex Vario	
Process connection	Welding adapter \varnothing 50 mm	
Sealing	Gasket	

Accessories

Items supplied	O-ring: 1 x (24 x 2 mm), EPDM, FDA compliant, E30054
----------------	--

E30130



Welding adapter for process sensors

WELDING ADAPT D50/G1 LEAK PORT

Accessories (optional)	O-ring: 1 x 24 x 2, FKM, FDA compliant, E30123
	Welding mandrel, E30452
	welding mandrel, water-cooled, E30532
	leak test, E30530
	grinding protection, E30160
Remarks	
Notes	recommended for wall thickness ≤ 3 mm. There are more suitable welding adapters for thicker walls.
Pack quantity	1 pcs.