

# E18162

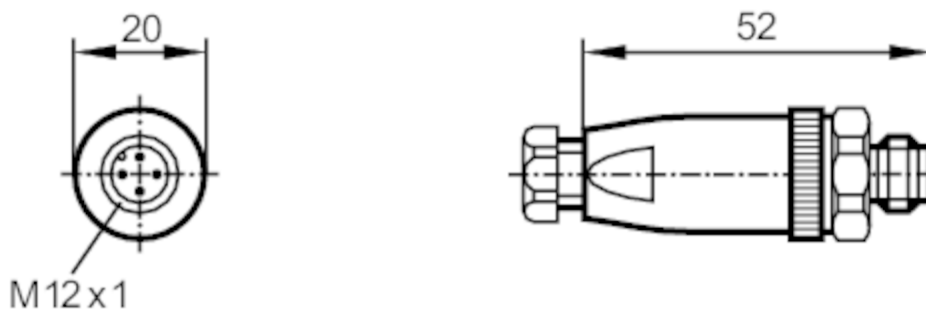

## Wirable plug

SSTGH040VASFPKG9



### Electrical data

Operating voltage	[V]	< 250 AC / < 300 DC
Max. current load total	[A]	4

### Operating conditions

Ambient temperature	[°C]	-40...85
Protection		IP 68

### Mechanical data

Weight	[g]	27.216
Dimensions	[mm]	20 x 20 x 52
Molded-body material		PA
Material nut		stainless steel (1.4571/316Ti)

### Remarks

Pack quantity		1 pcs.
---------------	--	--------

### Electrical connection

terminals: ...0.75 mm<sup>2</sup>; Cable sheath: Ø 6...8 mm

### Electrical connection - plug

Connector: 1 x M12, straight; coding: A; Moulded body: PA; Locking: stainless steel (1.4571/316Ti); Contacts: pre-coppered brass

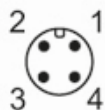

# E18162



## Wirable plug

SSTGH040VASFPKG9

### Connection

