

AL1373

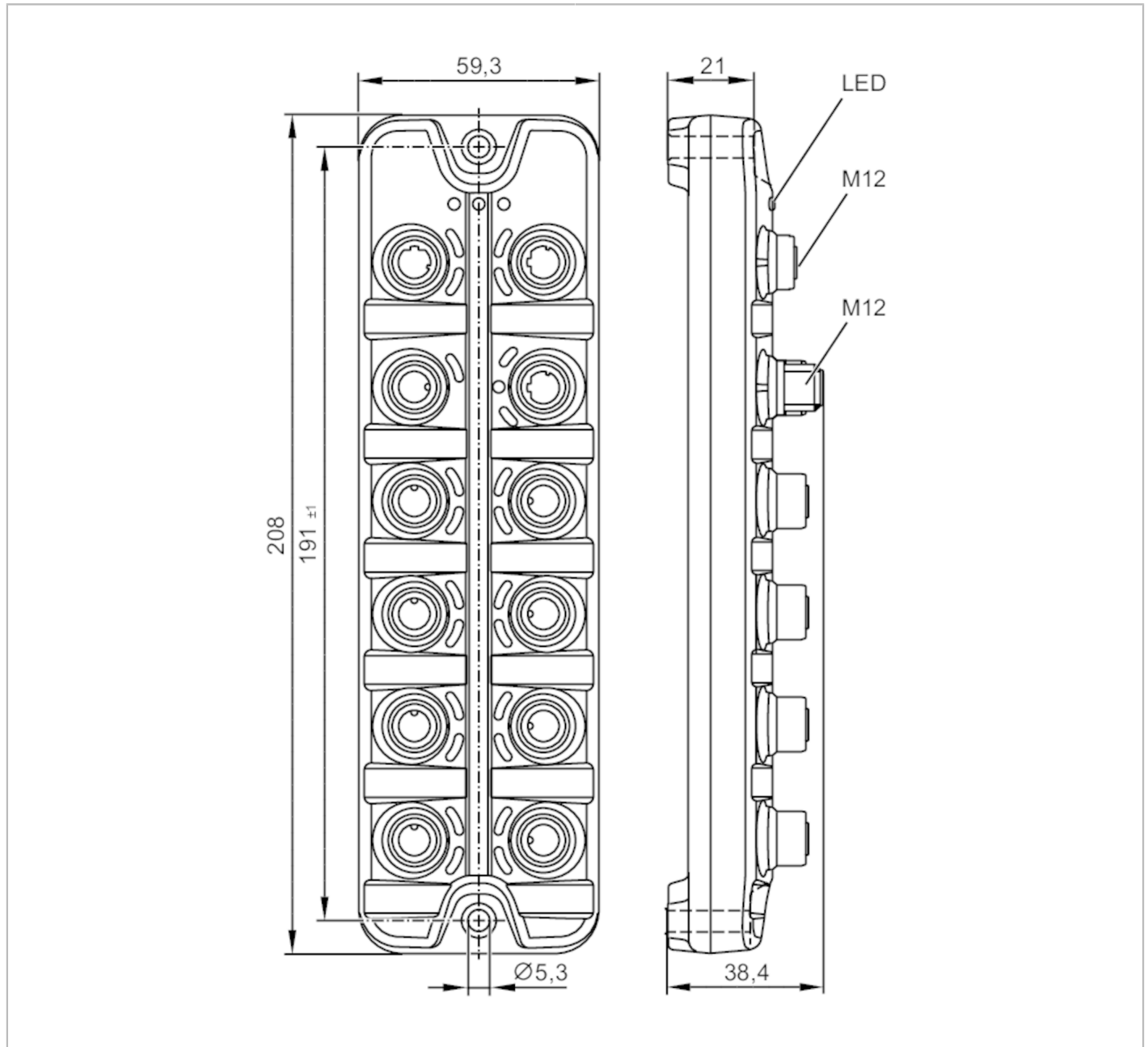

IO-Link master with POWERLINK interface

IO-Link Master DL PLI 8P IP69K



Application	
Application	hygienic systems; I/O modules for field applications
Daisy-chain function	fieldbus interface
Electrical data	
Operating voltage [V]	20...28 DC; (US ; to SELV/PELV)
Current consumption [mA]	300...3900; (US)
Protection class	III
Sensor supply US	
Max. current load total [A]	3.6



IO-Link master with POWERLINK interface

IO-Link Master DL PLI 8P IP69K

Inputs / outputs	
Total number of inputs and outputs	16; (configurable)
Number of inputs and outputs	Number of digital inputs: 16; Number of digital outputs: 8
Inputs	
Number of digital inputs	16; (IO-Link Port Class A: 8 x 2)
Switching level high [V]	11...28
Switching level low [V]	0...5
Digital inputs protected against short circuits	yes
Outputs	
Number of digital outputs	8; (IO-Link Port Class A: 8 x 1)
Max. current load per output [mA]	300
Short-circuit proof	yes
Interfaces	
Communication interface	Ethernet; IO-Link
Ethernet - POWERLINK	
Transmission standard	10Base-T; 100Base-TX
Transmission rate	10 MBit/s; 100 MBit/s
Protocol	POWERLINK
Factory settings	IP address: 192.168.100.1
	subnet mask: 255.255.255.0
	gateway IP address: 0.0.0.0
	MAC address: see type label
Ethernet - Internet of Things	
Transmission standard	10Base-T; 100Base-TX
Transmission rate	10 MBit/s; 100 MBit/s
Protocol	MQTT JSON
Factory settings	IP address: 169.254.x.x
	subnet mask: 255.255.0.0
	gateway IP address: 0.0.0.0
	MAC address: see type label
Note on interfaces	Safety protocol: HTTPS
IO-Link Master	
Transmission type	COM1 (4,8 kBaud); COM2 (38,4 kBaud); COM3 (230,4 kBaud)
IO-Link revision	1.1
Number of ports class A	8
Operating conditions	
Ambient temperature [°C]	-25...60
Storage temperature [°C]	-25...85
Max. relative air humidity [%]	90
Protection	IP 65; IP 66; IP 67; IP 69K; (operation with stainless steel protective caps: IP 69K)
Protection rating (NEMA 250)	6P
Degree of soiling	2

AL1373



IO-Link master with POWERLINK interface

IO-Link Master DL PLI 8P IP69K

Chemical media	ISO 16750-5 NEMA 250 5.13.1	HLP, CC, DB, DC, DD, CA AA
----------------	--------------------------------	-------------------------------

Tests / approvals

EMC	EN 61000-6-2 EN 61000-6-4	
Shock resistance	DIN EN 60068-2-27	
Vibration resistance	DIN EN 60068-2-64 2009-04 DIN EN 60068-2-6 2008-10	
MTTF [years]		78

Mechanical data

Weight [g]	423.6
Housing	rectangular
Type of mounting	Backplane mounting
Dimensions [mm]	208 x 59.3 x 38.4
Material	housing: PA grey; Socket: stainless steel (1.4404 / 316L)
Sealing material	EPDM

Accessories

Items supplied	Protective cap: 1 x M12, stainless steel, E12542
----------------	--

Remarks

Remarks	Further information is available in the manual.
Pack quantity	1 pcs.

Electrical connection - Ethernet

Connector: 3 x M12; coding: D; sealing: EPDM



Powerlink X21, X22

1	TX +
2	RX +
3	TX -
4	RX -
5	not used

IoT X23

1	TX +
2	RX +
3	TX -
4	RX -
5	not used

AL1373



IO-Link master with POWERLINK interface

IO-Link Master DL PLI 8P IP69K

Electrical connection - IO-Link

Connector: 8 x M12; coding: A; sealing: EPDM



IO-Link Port Class A X01...X08

1	Sensor supply (US) L+
2	Digital input
3	Sensor supply (US) L-
4	C/Q IO-Link
5	not used

Electrical connection - voltage supply

Connector: 1 x M12; coding: A



X31

1	+ 24 V DC (US)
2	not used
3	GND (US)
4	not used