

# AL1331

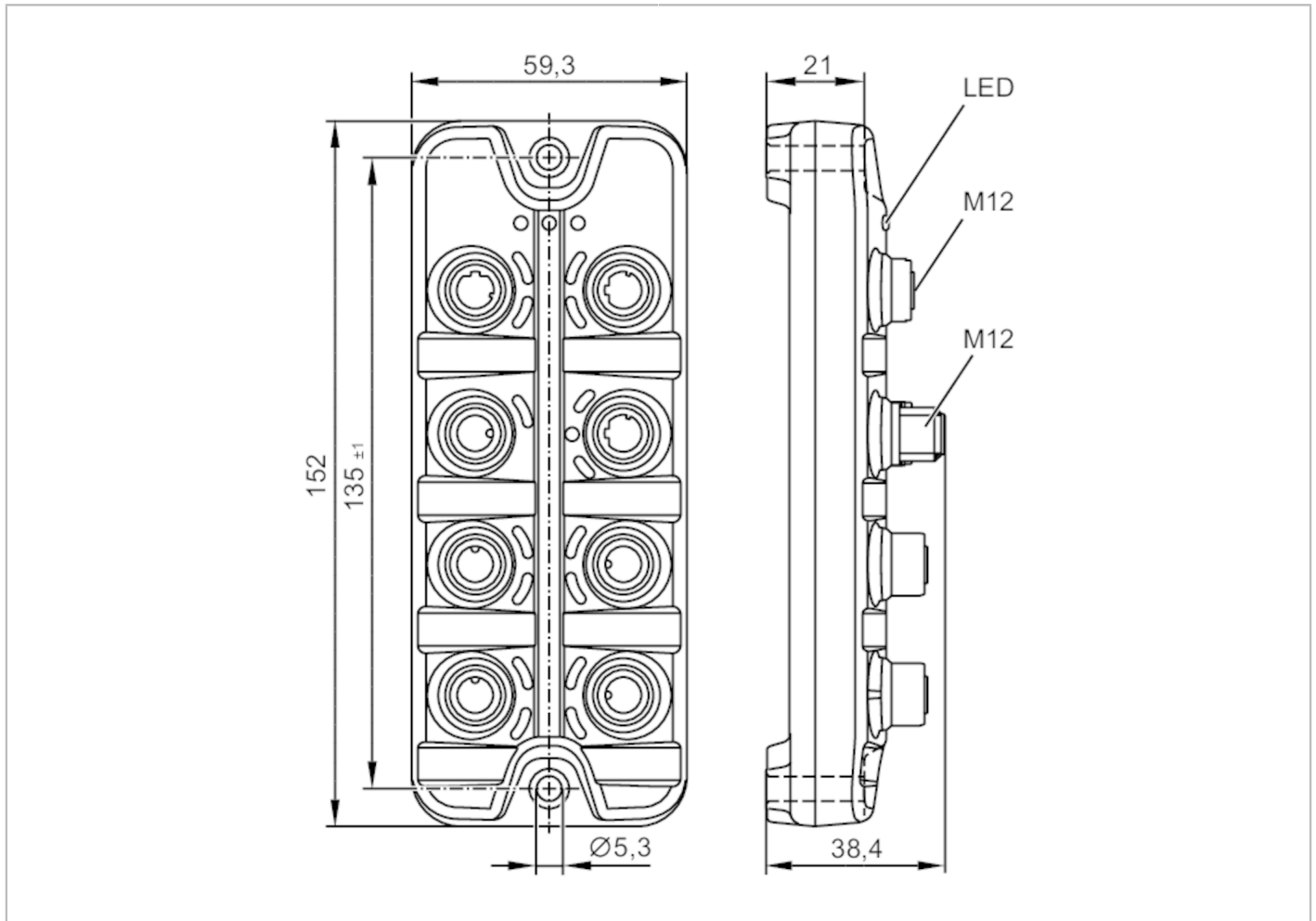

## IO-Link master with EtherCAT interface

IO-Link Master DL EC 4P IP69K



Application	
Application	hygienic systems; I/O modules for field applications
Daisy-chain function	fieldbus interface
Electrical data	
Operating voltage [V]	20...28 DC; (US ; to SELV/PELV)
Current consumption [mA]	300...3900; (US)
Protection class	III
Sensor supply US	
Max. current load total [A]	3.6
Inputs / outputs	
Total number of inputs and outputs	8; (configurable)
Number of inputs and outputs	Number of digital inputs: 8; Number of digital outputs: 4
Inputs	
Number of digital inputs	8; (IO-Link Port Class A: 4 x 2)
Switching level high [V]	11...28
Switching level low [V]	0...5



## IO-Link master with EtherCAT interface

IO-Link Master DL EC 4P IP69K

Digital inputs protected against short circuits	yes	
<b>Outputs</b>		
Number of digital outputs	4; (IO-Link Port Class A: 4 x 1)	
Max. current load per output [mA]	300	
Short-circuit proof	yes	
<b>Interfaces</b>		
Communication interface	Ethernet; IO-Link	
<b>Ethernet - EtherCAT</b>		
Transmission standard	100Base-TX	
Transmission rate	100 MBit/s	
Protocol	EtherCAT	
Factory settings	MAC address: see type label	
Note on interfaces	AoE (ADS over EtherCAT)	
	CoE (CANopen over EtherCAT)	
	EoE (Ethernet over EtherCAT)	
	FoE (File Access over EtherCAT)	
<b>Ethernet - Internet of Things</b>		
Transmission standard	10Base-T; 100Base-TX	
Transmission rate	10 MBit/s; 100 MBit/s	
Protocol	MQTT JSON	
Factory settings	IP address: 169.254.x.x	
	subnet mask: 255.255.0.0	
	gateway IP address: 0.0.0.0	
	MAC address: see type label	
Note on interfaces	Safety protocol: HTTPS	
<b>IO-Link Master</b>		
Transmission type	COM1 (4,8 kBaud); COM2 (38,4 kBaud); COM3 (230,4 kBaud)	
IO-Link revision	1.1	
Number of ports class A	4	
<b>Operating conditions</b>		
Ambient temperature [°C]	-25...60	
Storage temperature [°C]	-25...85	
Max. relative air humidity [%]	90	
Protection	IP 65; IP 66; IP 67; IP 69K; (operation with stainless steel protective caps: IP 69K)	
Protection rating (NEMA 250)	6P	
Degree of soiling	2	
Chemical media	ISO 16750-5	HLP, CC, DB, DC, DD, CA
	NEMA 250 5.13.1	AA
<b>Tests / approvals</b>		
EMC	EN 61000-6-2	
	EN 61000-6-4	
Shock resistance	DIN EN 60068-2-27	
Vibration resistance	DIN EN 60068-2-64 2009-04	
	DIN EN 60068-2-6 2008-10	

# AL1331



## IO-Link master with EtherCAT interface

IO-Link Master DL EC 4P IP69K

MTTF	[years]	95
------	---------	----

### Mechanical data

Weight	[g]	283
Housing		rectangular
Type of mounting		Backplane mounting
Dimensions	[mm]	152 x 59.3 x 38.4
Material		housing: PA grey; Socket: stainless steel (1.4404 / 316L)
Sealing material		EPDM

### Accessories

Items supplied		Protective cap: 1 x M12, stainless steel, E12542
----------------	--	--

### Remarks

Remarks		Further information is available in the manual.
Pack quantity		1 pcs.

### Electrical connection - Ethernet

Connector: 3 x M12; coding: D; sealing: EPDM



### EtherCAT X21, X22

1	TX +
2	RX +
3	TX -
4	RX -
5	not used

### IoT X23

1	TX +
2	RX +
3	TX -
4	RX -
5	not used

### Electrical connection - IO-Link

Connector: 4 x M12; coding: A; sealing: EPDM

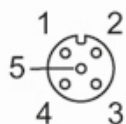

# AL1331



## IO-Link master with EtherCAT interface

IO-Link Master DL EC 4P IP69K

### IO-Link Port Class A X01...X04

1	Sensor supply (US) L+
2	Digital input
3	Sensor supply (US) L-
4	C/Q IO-Link
5	not used

### Electrical connection - voltage supply

Connector: 1 x M12; coding: A



### X31

1	+ 24 V DC (US)
2	not used
3	GND (US)
4	not used