

AL1307

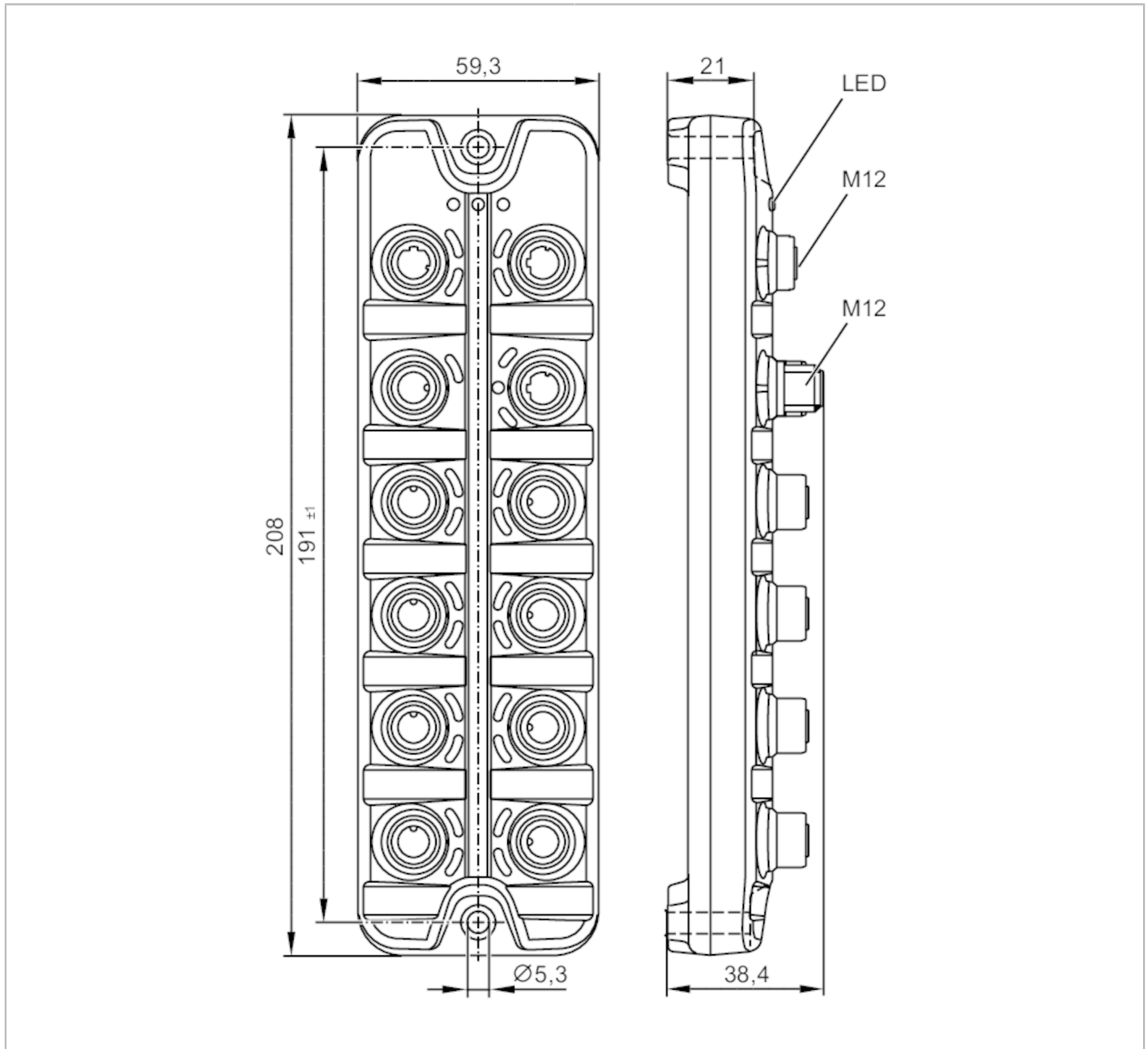

IO-Link master with Profinet interface

IO-Link Master DL PN 8P IP69K



Application	
Application	hygienic systems; I/O modules for field applications
Daisy-chain function	fieldbus interface
Electrical data	
Operating voltage [V]	20...28 DC; (US ; to SELV/PELV)
Current consumption [mA]	300...3900; (US)
Protection class	III
Sensor supply US	
Max. current load total [A]	3.6



IO-Link master with Profinet interface

IO-Link Master DL PN 8P IP69K

Inputs / outputs	
Total number of inputs and outputs	16; (configurable)
Number of inputs and outputs	Number of digital inputs: 16; Number of digital outputs: 8
Inputs	
Number of digital inputs	16; (IO-Link Port Class A: 8 x 2)
Switching level high [V]	11...28
Switching level low [V]	0...5
Digital inputs protected against short circuits	yes
Outputs	
Number of digital outputs	8; (IO-Link Port Class A: 8 x 1)
Max. current load per output [mA]	300
Short-circuit proof	yes
Interfaces	
Communication interface	Ethernet; IO-Link
Ethernet - PROFINET	
Transmission standard	100Base-TX
Transmission rate	100 MBit/s
Protocol	PROFINET
Factory settings	IP address: 0.0.0.0
	subnet mask: 0.0.0.0
	gateway IP address: 0.0.0.0
	MAC address: see type label
Note on interfaces	IO-Link Integration Edition 2
	CC-C (Conformance Class C) (IRT-Switch)
	S2 redundancy
	Netload Class III
	CiR (Configuration in Run)
	SNMP (Simple Network Management Protocol)
	MRP (Media Redundancy Protocol)
	Supported network topologies: line
	ring
Ethernet - Internet of Things	
Transmission standard	10Base-T; 100Base-TX
Transmission rate	10 MBit/s; 100 MBit/s
Protocol	MQTT JSON
Factory settings	IP address: 169.254.x.x
	subnet mask: 255.255.0.0
	gateway IP address: 0.0.0.0
	MAC address: see type label
Note on interfaces	Safety protocol: HTTPS
IO-Link Master	
Transmission type	COM1 (4,8 kBaud); COM2 (38,4 kBaud); COM3 (230,4 kBaud)
IO-Link revision	1.1
Number of ports class A	8

AL1307



IO-Link master with Profinet interface

IO-Link Master DL PN 8P IP69K

Operating conditions		
Ambient temperature	[°C]	-25...60
Storage temperature	[°C]	-25...85
Max. relative air humidity	[%]	90
Protection	IP 65; IP 66; IP 67; IP 69K; (operation with stainless steel protective caps: IP 69K)	
Protection rating (NEMA 250)	6P	
Degree of soiling	2	
Chemical media	ISO 16750-5	HLP, CC, DB, DC, DD, CA
	NEMA 250 5.13.1	AA

Tests / approvals		
EMC	EN 61000-6-2	
	EN 61000-6-4	
Shock resistance	DIN EN 60068-2-27	
Vibration resistance	DIN EN 60068-2-64 2009-04	
	DIN EN 60068-2-6 2008-10	
MTTF	[years]	76

Mechanical data		
Weight	[g]	429
Housing	rectangular	
Type of mounting	Backplane mounting	
Dimensions	[mm]	208 x 59.3 x 38.4
Material	housing: PA grey; Socket: stainless steel (1.4404 / 316L)	
Sealing material	EPDM	

Accessories	
Items supplied	Protective cap: 1 x M12, stainless steel, E12542

Remarks	
Remarks	Further information is available in the manual.
Pack quantity	1 pcs.

Electrical connection - Ethernet

Connector: 3 x M12; coding: D; sealing: EPDM



PROFINET X21, X22	
1	TX +
2	RX +
3	TX -
4	RX -
5	not used



IO-Link master with Profinet interface

IO-Link Master DL PN 8P IP69K

IoT X23

1	TX +
2	RX +
3	TX -
4	RX -
5	not used

Electrical connection - IO-Link

Connector: 8 x M12; coding: A; sealing: EPDM

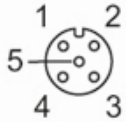

IO-Link Port Class A X01...X08

1	Sensor supply (US) L+
2	Digital input
3	Sensor supply (US) L-
4	C/Q IO-Link
5	not used

Electrical connection - voltage supply

Connector: 1 x M12; coding: A



X31

1	+ 24 V DC (US)
2	not used
3	GND (US)
4	not used