

AL1121

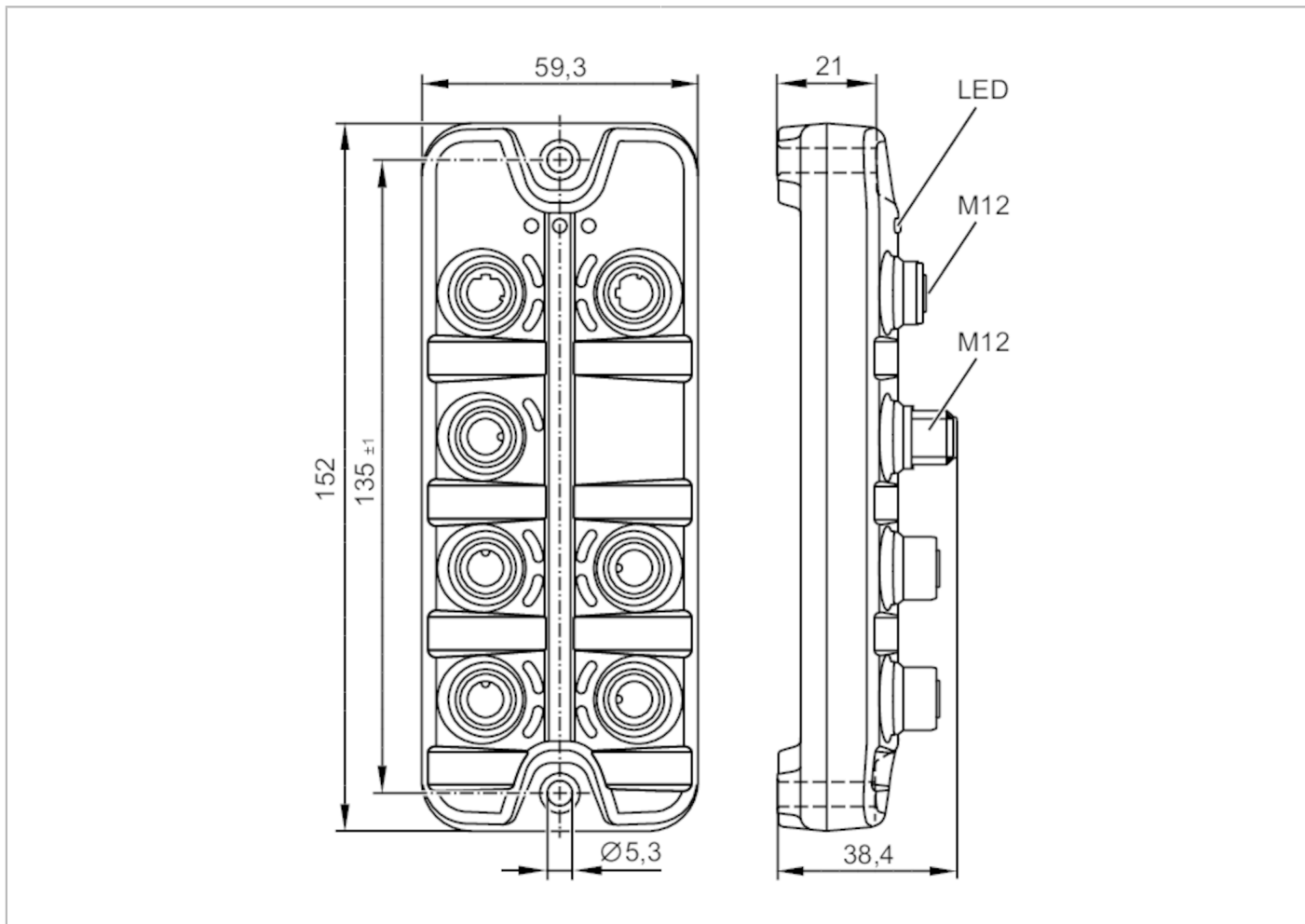

IO-Link master with EtherNet/IP interface

IO-Link Master SL EIP 4P IP69K



Application	
Application	hygienic systems; I/O modules for field applications
Daisy-chain function	fieldbus interface
Electrical data	
Operating voltage [V]	20...30 DC; (US ; to SELV/PELV)
Current consumption [mA]	300...3900; (US)
Protection class	III
Sensor supply US	
Max. current load total [A]	3.6
Inputs / outputs	
Total number of inputs and outputs	8; (configurable)
Number of inputs and outputs	Number of digital inputs: 8; Number of digital outputs: 4
Inputs	
Number of digital inputs	8; (IO-Link Port Class A: 4 x 2)
Switching level high [V]	11...30
Switching level low [V]	0...5



IO-Link master with EtherNet/IP interface

IO-Link Master SL EIP 4P IP69K

Digital inputs protected against short circuits	yes
Outputs	
Number of digital outputs	4; (IO-Link Port Class A: 4 x 1)
Max. current load per output [mA]	300
Short-circuit proof	yes
Interfaces	
Communication interface	Ethernet; IO-Link
Ethernet - EtherNet/IP	
Transmission standard	10Base-T; 100Base-TX
Transmission rate	10 MBit/s; 100 MBit/s
Protocol	EtherNet/IP
Factory settings	IP address: 192.168.1.250 subnet mask: 255.255.255.0 gateway IP address: 0.0.0.0 MAC address: see type label
Note on interfaces	DHCP, BOOTP, static DLR (Device Level Ring) Supported network topologies: line ring
IO-Link Master	
Transmission type	COM1 (4,8 kBaud); COM2 (38,4 kBaud); COM3 (230,4 kBaud)
IO-Link revision	1.1
Number of ports class A	4
Operating conditions	
Ambient temperature [°C]	-25...60
Storage temperature [°C]	-25...85
Max. relative air humidity [%]	90
Protection	IP 65; IP 66; IP 67; IP 69K; (operation with stainless steel protective caps: IP 69K)
Protection rating (NEMA 250)	6P
Degree of soiling	2
Chemical media	ISO 16750-5 HLP, CC, DB, DC, DD, CA NEMA 250 5.13.1 AA
Tests / approvals	
EMC	EN 61000-6-2 EN 61000-6-4
Shock resistance	DIN EN 60068-2-27
Vibration resistance	DIN EN 60068-2-64 2009-04 DIN EN 60068-2-6 2008-10
MTTF [years]	96
Mechanical data	
Weight [g]	273
Housing	rectangular
Type of mounting	Backplane mounting
Dimensions [mm]	152 x 59.3 x 38.4

AL1121



IO-Link master with EtherNet/IP interface

IO-Link Master SL EIP 4P IP69K

Material	housing: PA grey; Socket: stainless steel (1.4404 / 316L)
Sealing material	EPDM
Accessories	
Items supplied	Protective cap: 1 x M12, stainless steel, E12542
Remarks	
Remarks	Further information is available in the manual.
Pack quantity	1 pcs.

Electrical connection - Ethernet

Connector: M12; coding: D; sealing: EPDM



IN / OUT X21, X22

1	TX +
2	RX +
3	TX -
4	RX -
5	not used

Electrical connection - IO-Link

Connector: M12; coding: A; sealing: EPDM

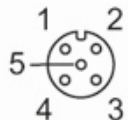

IO-Link Port Class A X01...X04

1	Sensor supply (US) L+
2	Digital input
3	Sensor supply (US) L-
4	C/Q IO-Link
5	not used

Electrical connection - voltage supply

Connector: M12; coding: A



AL1121



IO-Link master with EtherNet/IP interface

IO-Link Master SL EIP 4P IP69K

X31

1	+ 24 V DC (US)
2	not used
3	GND (US)
4	not used