

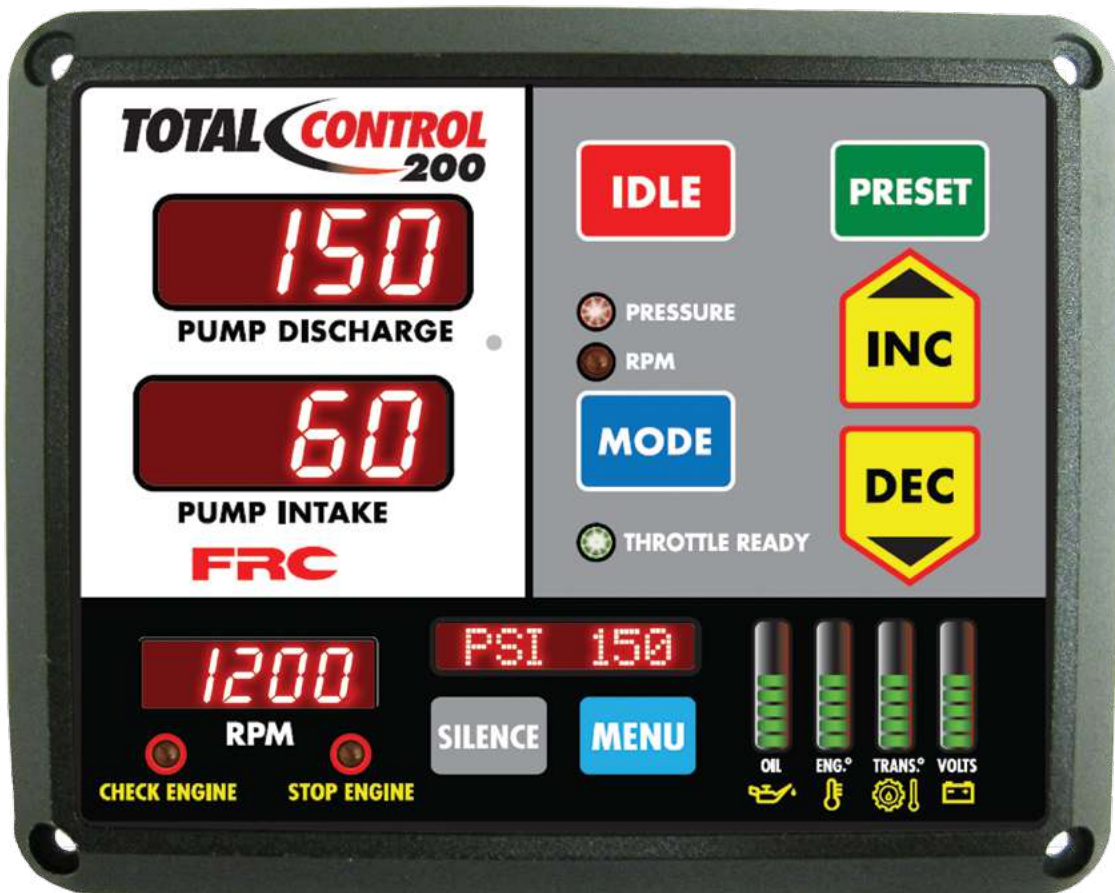

A Safe Fleet Brand



PRESSURE GOVERNOR, ENGINE MONITORING, AND MASTER PRESSURE DISPLAY MODEL TCA200



FIRE RESEARCH CORPORATION

www.fireresearch.com

26 Southern Blvd., Nesconset, NY 11767

TEL 631.724.8888 FAX 631.360.9727 TOLL FREE 1.800.645.0074

CONTENTS

Table of Contents

CONTENTS.....	2
INTRODUCTION	4
Overview.....	4
Features.....	4
Specifications.....	5
GENERAL DESCRIPTION	6
Components	6
Controls and Indicators.....	8
INSTALLATION	10
Install Control Module.....	10
Install Pressure Sensors	11
OPERATION	12
Controls.....	12
Pressure Mode Operation.....	14
RPM Mode Operation.....	16
Switching Between Operating Modes	17
Pump Discharge Pressure is High at Engine Idle	17
Detailed Information.....	18
Preset Settings (Pressure or RPM).....	19
High Idle	19
PROGRAMMING	20
CALIBRATION.....	22
Calibration Programs	22
Pump Sensor (Code C1 and C2).....	23
WIRING.....	24
Connectors and Cables.....	25
Pressure Sensor	26
Common Diagnostic Connector.....	27
Detroit Diesel ECU Connections.....	28
Detroit Diesel Harness Connections.....	29
High Idle Wiring	30
FLYBACK DIODE INFORMATION	31

List of Tables

Table 1. Pressure Sensor Output Voltage	5
Table 2. Error Codes	13
Table 3. Fault Warning Codes	13

List of Figures

Figure 1. Controls and Indicators.....	9
Figure 2. Control Module Mounting Dimensions.....	10
Figure 3. Pressure Sensor Dimensions.....	11
Figure 4. TCA200 12 and 8-Pin Connector Wiring.....	24
Figure 5. TCA200 Interface Wiring.....	25
Figure 6. Pressure Sensor Wiring.....	26
Figure 7. Common OEM 9-Pin Diagnostic Connector.....	27
Figure 8. DDEC III ECU Wiring TCA202-A00	28
Figure 9. DDEC IV, V & VI Series Wiring TCA202-C00.....	29
Figure 10. High Idle Wiring.....	30
Figure 11. Flyback Diode.....	31

INTRODUCTION

Overview

The all-in one pressure governor and instrument panel uses state-of-the-art programmable microprocessor technology. It maintains a steady pump discharge pressure by controlling engine speed or hold a selected engine RPM. It offers complete engine control and remote display in a single compact unit.

The governor operates in one of two modes, pressure or RPM. In pressure mode it maintains a constant pump discharge pressure. The discharge pressure is monitored, compared to the selected pressure setting, and the engine RPM is varied to keep the discharge pressure at the selected setting. In RPM mode it maintains a constant engine RPM. The pump discharge pressure is monitored and can vary, but, as a safety feature, it will be limited to an increase of 30 PSI. If the discharge pressure increases 30 PSI the governor automatically lowers the engine RPM to prevent a high pressure surge.

The panel has three 4-digit LED displays for pump discharge, pump intake, and engine RPM. The message display shows pressure and RPM settings; fault and error code information; detailed engine data and program features. There are four LED bar graphs that provide a constant display of the safe operating ranges for engine oil pressure, engine coolant temperature, transmission temperature, and battery voltage. (For detailed information with the exact numbers and units of measure the MENU button is pressed.)

All controls and indicators are located on the front of the control module.

Features

- Power Up in Pressure Mode
- Automatic Regulation of Pump Discharge Pressure
- Manual Control of Pressure or Engine RPM Settings
- Field Programmable Presets
- Diagnostic Capabilities
- No Pressure or RPM Variation When Changing Modes
- Limits Increase of Pressure When in RPM Mode
- Recognition of No Water Condition With Automatic Response
- Interlock Signal Recognition and Throttle Ready LED
- Return to Engine Idle With the Push of a Button
- Accumulated Engine and Pump Hours

Specifications

The panel provides the functions, controls, and digital readouts needed for the management of pump discharge pressure.

Control Module

Supply Power:	12 VDC (Program Option for 24 VDC))
Supply Current:	0.8 A Low Light - 1.2 A Bright Light
Dimensions:	7 1/2" Wide by 6" High by 2 1/4" Deep
Unit of Measure:	PSI °F (Program Option for kPa, Bar, °C)

LED Bar Graphs

Engine Oil Pressure:	10 to 100 PSI
Engine Coolant Temperature:	150 to 240 °F
Transmission Temperature:	140 to 300 °F
Battery Voltage:	11.5 to 15.5 VDC

Pressure Sensor

	Discharge	Intake
Model Number:	XE-FP4000PT3	XE-IO3100PT3
Pressure Range:	0 - 600 PSI (0 to 4000 kPa)	-30 in/Hg - 600 PSI (-100 to 4000 kPa)
Proof Pressure:	1200 PSI	1200 PSI
Excitation Voltage:	5 VDC	5 VDC
Output Voltage:	0.5 - 4.75 VDC (See Table 1)	

Table 1. Pressure Sensor Output Voltage

	0psi	100psi	150psi	200psi	250psi	300psi	600psi
Discharge Sensor XE-FP4000PT3	0.5vdc	1.21vdc	1.56vdc	1.92vdc	2.27vdc	2.625vdc	4.75vdc
Intake Sensor XE-IO3100PT3	0.604vdc	1.295vdc	1.640vdc	1.985vdc	2.331vdc	2.667vdc	4.75vdc

GENERAL DESCRIPTION

All controls and indicators are located on the front of the control module.

Components

The pressure governor and instrument panel consist of the following components:

Control Module

Intake Pressure Sensor

Discharge Pressure Sensor

Audible Alarm Buzzer

Cables

Control Module

The control module is waterproof and takes up 7 1/2 by 6 inches of panel space. All controls, indicators, and displays are located on the front of the control panel. (Refer to Controls and Indicators.)

Intake Pressure Sensor

The pressure sensor is mounted on the pump intake manifold. It provides an input signal to the control module that is proportional to the intake pressure.

Discharge Pressure Sensor

The pressure sensor is mounted on the pump discharge manifold. It provides an input signal to the control module that is proportional to the discharge pressure.

Audible Alarm Buzzer

A ground is provided at the 8-pin connector pin 2 to activate the buzzer (max current: 300mA).

High Idle Wiring

The programming includes a high idle function. To activate the high idle provide a +12 VDC High Idle Active Input. (Refer to Figure 8. High Idle Wiring.)

Note: It is important that the connection to the Interlock Input from the High Idle circuit be isolated from the apparatus interlock wiring with the two diodes. Refer to the wiring diagram. **The pump must NOT be engaged when using the high idle function.**

The high idle is set at about 1000 RPM at the factory. (This value will vary depending on the specific engine.) To adjust this setting refer to High Idle in the Operation Section.

Cables

There are two connectors on the control module for all input/output signals, one 8-pin connector and one 12-pin connector.

When replacing an older Detroit Diesel governor, connectors with wiring are provided to utilize some of the existing harness. New wiring is required for the intake pressure sensor and engine control. Refer to the Wiring Section.

Controls and Indicators

All controls and indicators are located on the front of the control module. (Refer to Figure 1.)

PUMP DISCHARGE and PUMP INTAKE Displays

Shows the pump discharge and intake pressure during normal operations and codes during programming.

MODE Button

Selects the pressure or RPM mode of operation.

RPM LED

The red LED is on to indicate operation in the RPM mode.

PRESSURE LED

The amber LED is on to indicate operation in the pressure mode.

IDLE Button

When pressed immediately sets the engine RPM to idle. This button can be used in an emergency or for normal shut down after operations.

PRESET Button

Press to change/select a pre-programmed value for pressure or RPM setting.

INC / DEC Buttons

During operations the buttons increase and decrease pressure or RPM setting.

VOLTS LED Display

Shows battery voltage safe range with green LEDs. The LEDs flash red when the voltage is outside normal limits.

TRANS.° LED Display

Shows transmission temperature safe range with green LEDs. The LEDs flash red when the temperature is high.

ENG.° LED Display

Shows engine coolant temperature safe range with green LEDs. The LEDs flash red when the temperature is high.

OIL LED Display

Shows engine oil pressure safe range with green LEDs. The LEDs flash red when the pressure is low.

MENU Button

Used when accessing detailed information and program features. (Detailed information shown includes engine oil pressure, engine coolant temperature, transmission temperature, battery voltage, engine hours, and pump hours with the exact measure and units.)

SILENCE Button

Suppresses audio alarms and used in programming.

STOP ENGINE / CHECK ENGINE LED

Repeats the engine warnings from the cab.

RPM Display

Shows the engine RPM during normal operations.

Message Display

The message display shows the pressure or RPM setting during normal operations, warning alarms as they occur, and detailed information when the menu button is pressed. It shows the time and date when the throttle ready LED is off. It is also used to show stored data and program features.

THROTTLE READY LED

This LED is on when the required interlock conditions are met and the governor is ready to begin operations.

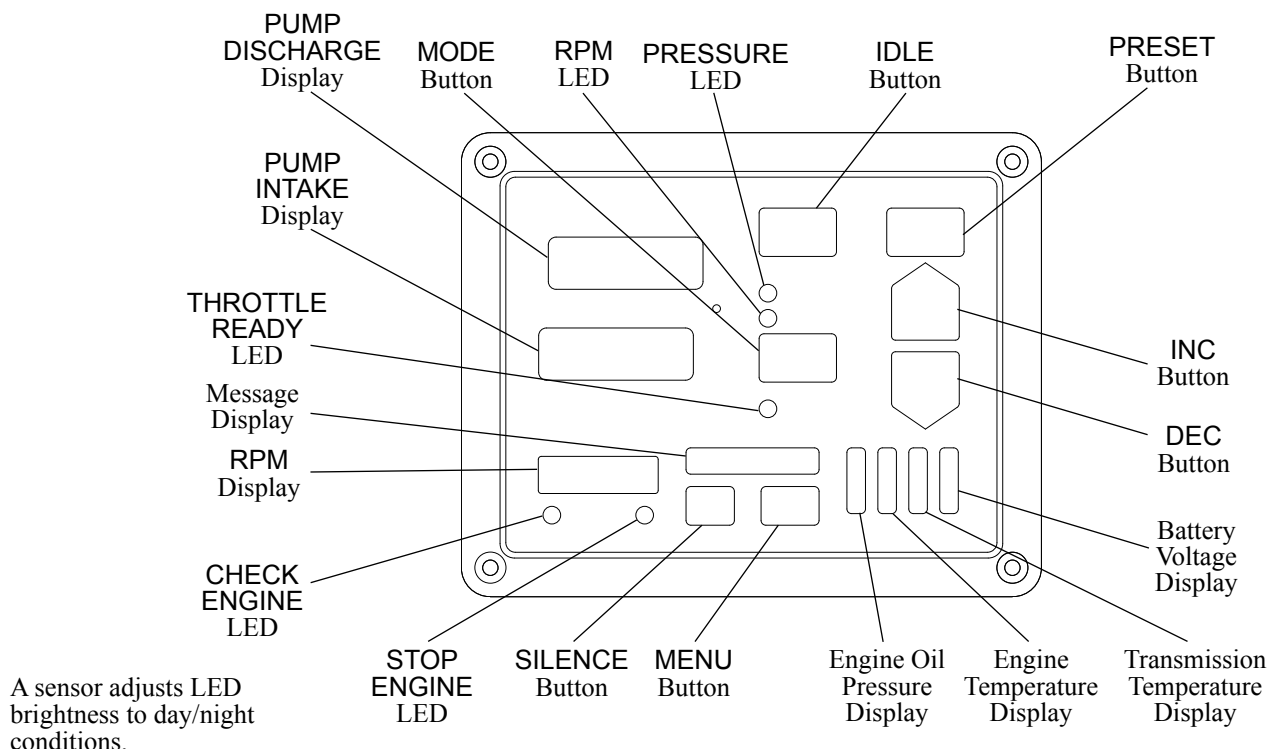

Figure 1. Controls and Indicators

INSTALLATION

Install Control Module

1. Measure and mark mounting location for control module cutout and mounting screw holes. Make sure there is clearance behind the panel for the module and cables before cutting holes. Refer to Figure 2 for layout and dimensions.
2. Cut out a 6 5/8 by 5 1/8 inch hole.
3. Drill four holes for mounting screws (10-32 mounting hardware is recommended).
4. Place control module in position and secure with four screws.
5. Connect cables at rear of the control module. (Refer to Wiring Section.)

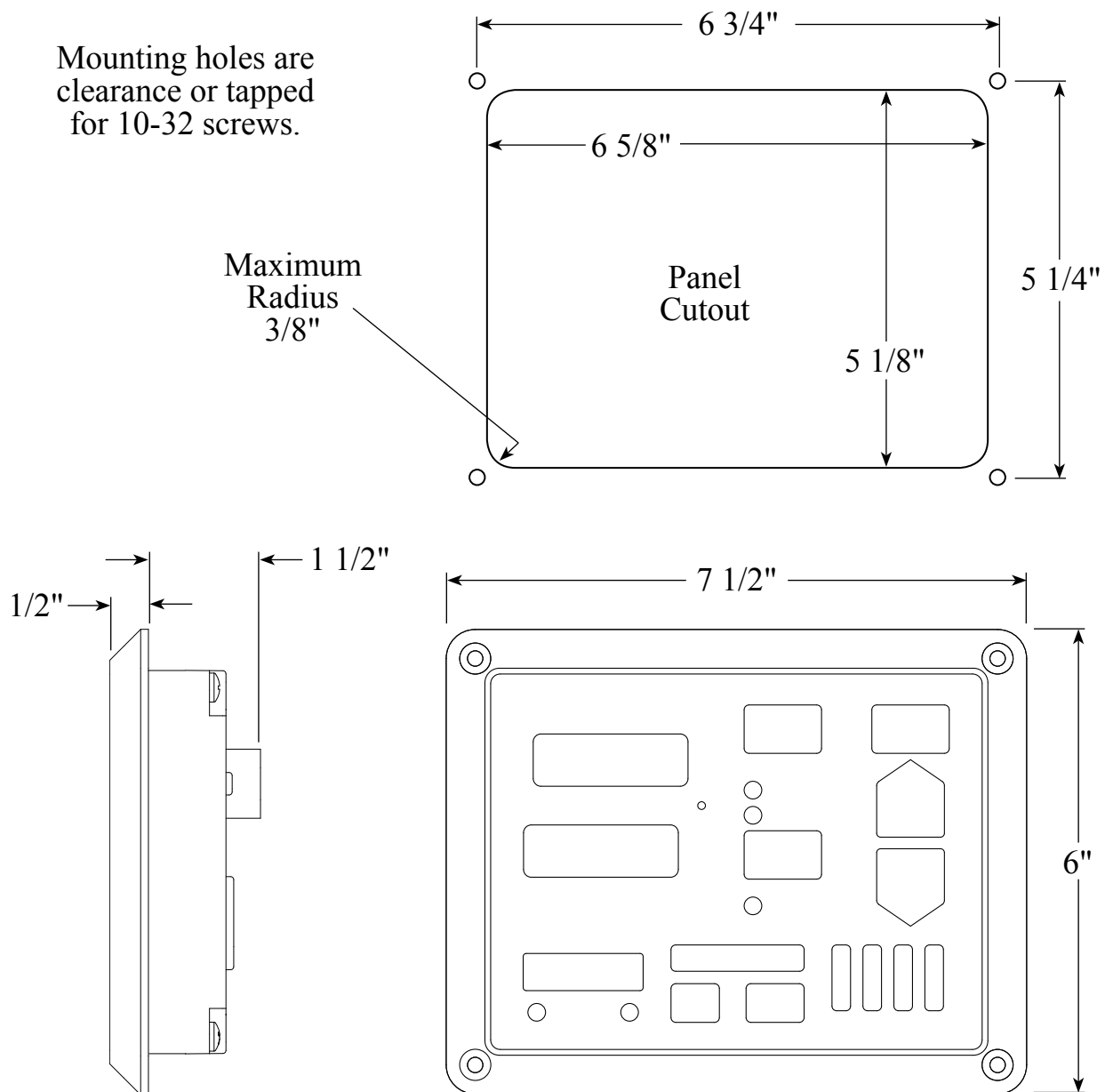

Figure 2. Control Module Mounting Dimensions

Install Pressure Sensors

The two pressure sensors are mounted on the discharge and intake manifolds of the pump. If there is a check valve in the discharge side of the pump, mount the discharge sensor before the check valve. T-fittings can be used to mount the pressure sensors.

Note: Install the pressure sensor upright so that the water in the end of the pressure sensor is able to drain back into the pipe.

1. Screw the sensor into a 1/4-18 NPT hole.

Caution: Do not use the main body that houses the electronics to tighten the pressure sensor. Damage to the sensor may occur.

2. Tighten the sensor with a 7/8 inch wrench on the lower hex fitting.
3. Connect the pressure sensor cable from the control module to the pressure sensor. (Refer to Wiring Section.)

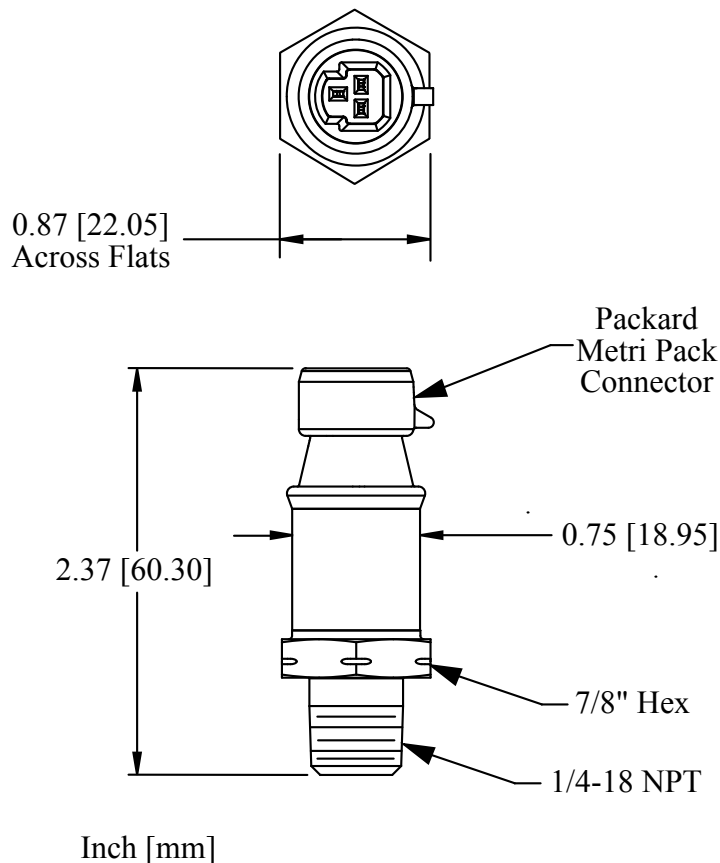

Caution: Do not use the main body that houses the electronics to tighten the sensor. Damage to the sensor may occur.

Caution: The discharge and intake pressure sensors are the same size. Ensure the correct sensor is installed on the correct manifold. Refer to Table 1.

Figure 3. Pressure Sensor Dimensions

OPERATION

On power-up the governor is in the pressure mode of operation. The RPM display shows engine at idle RPM, the four LED bar graphs are green indicating readings within normal ranges, and the message display alternates between showing the date and time.

If a monitored function is not within normal parameters the display flashes, the RPM display shows an error or fault warning code and a description shows in the message display. (Refer to Table 2. Error Codes or Table 3. Fault Warning Codes.)

If one of the inputs displayed by the LED bar graphs is not within normal range the LEDs will be red.

When all necessary throttle enables are active and the interlock circuit is complete the THROTTLE READY LED lights and the governor is ready to control the engine RPM.

Controls

INC/DEC Buttons

The INC and DEC buttons are used to change pressure and RPM settings or program preset values. The rate and amount the numbers change when a button is pressed depends on the mode and how long the button is held.

Pressure Mode. Press either button momentarily to change the pressure setting by 1 PSI. Press and hold the button for more than 2 seconds and the pressure setting changes by 5 PSI twice and then by 10 PSI until the button is released.

RPM Mode. Press either button momentarily to change the RPM setting by 10 RPM. Press and hold the button for more than 2 seconds and the RPM setting changes by 50 RPM twice and then by 100 RPM until the button is released.

MODE Button

Switches between pressure and RPM modes.

MENU Button

Shows detailed information in the message display.

SILENCE Button

The silence button is used to suppress an optional audio alarm.

PRESET Button

Selects a pre-programmed value for pressure or RPM setting.

Table 2. Error Codes

RPM Display	Message Display	Probable Cause
		Note: Not all inputs are used for all engines. For systems that use a datalink to pass information the datalink cable and connectors or ECM programming would be the probable cause.
E01	No Data	>Datalink cable not connected / connected to wrong port >Broken wire / bad connector contact on datalink cable
E02	No RPM	Engine RPM not detected >Datalink cable not connected / connected to wrong port >Engine not running / ignition key on
E03	No Trans T. Sensor	No Transmission Data Detected >Datalink cable not connected / connected to wrong port >Broken wire / bad connector contact on datalink cable
E04	No Eng Oil Sensor	No Engine Oil Pressure Data Detected >Datalink cable not connected / connected to wrong port >Broken wire / bad connector contact on datalink cable
E05	No D. Sensor	No Discharge Pressure Sensor Detected >Sensor cable not connected >Broken wire / bad connector contact on sensor cable >Defective pressure sensor
E06	No I. Sensor	No Intake Pressure Sensor Detected >Sensor cable not connected >Broken wire / bad connector contact on sensor cable >Defective pressure sensor
E07	No Eng T. Sensor	No Coolant Temperature Data Detected >Datalink cable not connected / connected to wrong port >Broken wire / bad connector contact on datalink cable

Table 3. Fault Warning Codes

RPM Display	Message Display	Description
F01	Hi Batt	High Battery Voltage
F02	Low Batt	Low Battery Voltage
F03	Hi Trans	High Transmission Temperature
F04	Low Oil	Low Engine Oil Pressure
F07	Hi Eng T.	High Engine Coolant Temperature
F08	No Water	Out of Water Mode
F09	No Resp	Engine Does Not Respond

Pressure Mode Operation

In the pressure mode of operation the **PRESSURE** LED is on. The governor maintains a constant discharge pressure within system capabilities. It adjusts the engine RPM automatically to compensate for variations in pressure.

Note: When changing from RPM to pressure mode during operations, hold the **MODE** button for 3 seconds. The pressure setting is the pressure that the pump was operating at in RPM mode.

1. Press and hold **MODE** button for 3 seconds.

Result: **PRESSURE** LED goes on.

2. Press **PRESET** and/or the **INC DEC** buttons to select pressure setting.

Result: Message display shows pressure setting, engine RPM changes.

3. Press **IDLE** button after operations to bring engine to idle RPM.

Result: Message display shows **IDLE**, engine at idle RPM.

Opening/Closing Discharge Valves

In pressure mode the governor maintains the pressure setting regardless of the number of discharge lines that are opened or closed providing there is a sufficient water supplied. As lines are opened the discharge pressure starts to drop, and the governor raises the engine RPM to maintain the required pressure. As lines are closed and the discharge pressure starts to rise, the governor lowers the engine RPM to maintain the required pressure.

Operating From a Pressurized Supply

When operating from a pressurized water source (hydrant, in-relay, etc.), the intake supply should be routed through a valve. If the pressurized source fails, the pump operator can close the valve. This eliminates the chance of sharp pressure spikes at the pump intake if the supply is resumed suddenly. The operator must open this valve slowly when the supply is resumed to help prevent pressure spikes.

Running Away From Water, Low Water, or No Supply Water

There are situations during pump operations when there may be low or no supply water. This can be due to an empty water tank, a problem on the intake line, air in the pump, changing the water source, or an insufficient water supply.

The governor constantly monitors discharge pressure and compares it to the engine RPM. It is programmed to limit RPM increases when conditions arise that fall outside normal operating parameters.

Running Away From Water: If the discharge pressure starts dropping while operating in pressure mode, the governor will increase the engine RPM and attempt to maintain the selected pressure setting. If pressure drops and an increase in RPM does not bring the pressure back up, the governor recognizes this as a running away from water condition. When this condition occurs the governor will switch to the RPM limit mode and limit the engine RPM accordingly.

RPM Limit Mode: When the RPM limit mode is in effect the PRESSURE LED will stay on. To alert the operator the RPM LED and the RPM display flash, and the message display flashes LO WATER. When the pressure comes back up, the RPM limit mode is canceled and the governor switches back to normal operation in pressure mode with the existing pressure setting.

In some cases the pressure may not come back up but remains at a level above 45 PSI. In the RPM limit mode the governor will behave like a manual throttle and the operator can raise or lower the engine RPM by pressing INC/DEC buttons. In this mode the pressure setting will not change, the PRESET button is disabled, and if the engine is set to idle using the IDLE button, the governor comes out of RPM Limit Mode and cancels the pressure setting.

Low Water Cycle: If the discharge pressure is below 45 PSI but stays above 15 PSI the governor goes into a low water cycle. It sets the engine at 1100 RPM, if the pressure does not rise above 45 PSI in 7 seconds the governor sets the engine at idle RPM. The governor repeats this low water cycle as long as the discharge pressure is between 15 and 45 PSI. When the pressure rises above 45 PSI the governor resumes normal operation. (The values for RPM and PSI in the low water cycle are programmable and may vary for some engine/pump combinations.)

No Supply Water: If the discharge pressure is below 15 PSI the engine RPM is set to idle. If within 3 minutes the discharge pressure rises above 15 PSI the governor enters the low water cycle. If the discharge pressure does not rise above 15 PSI within 3 minutes the governor stays at engine idle and cancels the pressure setting. To restart pumping the operator will have to take action (press PRESET and/or INC/DEC buttons to select pressure setting).

RPM Mode Operation

In the RPM mode of operation the RPM LED is on. The governor maintains a constant engine RPM.

The pump discharge pressure can vary but, as a safety feature, the governor limits the increase in pressure to 30 PSI over the last established PSI value. As the discharge pressure approaches this limit the governor will automatically lower the RPM to prevent a high pressure surge. The RPM LED blinks as the governor sets a lower RPM. This lower RPM will be the new operating RPM setting.

Note: When changing from pressure to RPM mode during operations, hold the MODE button for 3 seconds. The RPM setting is the RPM that the pump was operating at in pressure mode.

1. Press and hold MODE button for 3 seconds.

Result: RPM LED goes on.

2. Press PRESET and/or the INC DEC buttons to select RPM setting.

Result: Message display shows RPM setting, engine RPM changes.

3. Press IDLE button after operations to bring engine to idle RPM.

Result: Message display shows IDLE, engine at idle RPM.

Switching Between Operating Modes

- No variation in discharge pressure or RPM occurs when changing between pressure and RPM modes.
- When changing to RPM mode, the RPM setting is the RPM that the pump was operating at in pressure mode.
- When changing to pressure mode the pressure setting is the pressure that the pump was operating at in RPM mode.

When the engine is at idle RPM:

Press the **MODE** button and the governor switches modes immediately.

When the engine RPM is above idle:

Press and hold the **MODE** button for 3 seconds and the governor changes modes. (This is to avoid an accidental change over if the buttons get bumped.)

Pump Discharge Pressure is High at Engine Idle

Once the governor has set the engine to idle, it can do no more to reduce discharge pressures. To reduce discharge pressure the pump operator can gate incoming water, reduce pressure at the intake relief valve, gate discharges, or disable the pump.

Detailed Information

The four LED bar graphs provide a constant display of the safe operating ranges for engine oil pressure, engine coolant temperature, transmission temperature, and battery voltage. They do not show exact numbers or units of measure. Detailed information is shown in the message display when the MENU button is pressed. Engine hours and pump hours are also shown.

Show Detailed Information

Note: Detailed information is a display only mode and no changes can be made to the data.

The MENU button allows the operator to gain access to detailed information. Each time the MENU button is pressed the display scrolls to show the next value.

The message display will show the following:

Eng Oil	###PSI	(programmable for kPa or Bar)
Eng Temp	###°F	(programmable for °C)
Trans T.	###°F	(programmable for °C)
Batt VDC	##.#	
Eng Hrs	####	
Pump Hrs	####	

The message display reverts to normal operation after 20 seconds if no buttons are pressed or immediately when a button other than the MENU button is pressed.

Preset Settings (Pressure or RPM)

The preset button allows the operator to go to a pre-programmed pressure or RPM setting during operations. The setting will be shown in the message display. This procedure is to change the setting in the program.

Note: The engine must be running and the pump engaged interlock circuit must be closed (the THROTTLE READY LED **must be on**).

1. Press IDLE button.

Result: Engine goes to idle RPM

2. Press MODE button to select which setting to change.

Result: LED indicator goes on for mode selected.

Note: The message display must show IDLE before changing the preset.

3. Press and hold PRESET button. (Continue to hold through step 4.)

Result: Message display flashes then shows **preset...** after 5 seconds the current setting shows.

4. Press the INC DEC buttons to change preset setting.

5. Release PRESET button.

Result: The new preset is programmed. Message display shows IDLE.

High Idle

The governor programming includes a high idle function. To activate the high idle set interlocks as called for by SOP (normally this would include the transmission in neutral and the parking brake on). Set the High Idle switch to ON.

Note: The pump must NOT be engaged when using the high idle function and the THROTTLE READY LED will be off.

Change High Idle Setting

Note: The high idle is set at about 1000 RPM at the factory.

1. With the engine running, set the high idle switch to ON.

2. Press and hold PRESET button for 3 seconds.

Result: Message display will flash the high idle setting.

3. Keep pressing the PRESET button and press the INC/DEC buttons to set desired RPM.

4. Release PRESET button to store the new high idle setting.

PROGRAMMING

The following program functions are always available to view and change:

P1 - Software Program Revision Number - Read Only

P2 - Product Manufacturing Date - Read Only

P3 - Set Current Date - Read/Write

P4 - Set Current Time - Read/Write

P5 - Retrieve Fault Codes - Read Only

Access Program Features

Note: When the program (P) code is flashing in the PUMP INTAKE display, press the INC or DEC button to scroll through the P-codes or press the SILENCE button to exit the programming mode.

1. Press the SILENCE button and hold it until the RPM display shows four dashes - - - - and the message display shows ENTER--- . Release the button.

Result: P 1 flashes in the PUMP INTAKE display. The message display shows the program revision number PROG REV V100.03.

2. Press the INC button.

Result: P 2 flashes in the PUMP INTAKE display. The message display shows the manufacturing date MFG DATE 09AUG'07 (ddmmm'yy).

3. Press the INC button.

Result: P 3 flashes in the PUMP INTAKE display. The message display shows the current date SET DATE 17AUG'07.

4. To Change the Date: (If not go to step 5.)

- a. Press the MENU button.

Result: P 3 stops flashing. The message display shows the current date with the year flashing.

- b. Press the INC or DEC button to change the year.

- c. Press the MENU button.

Result: The month flashes.

- d. Press the INC or DEC button to change the month.

- e. Press the MENU button.

Result: The day flashes.

- f. Press the INC or DEC button to change the day.

- g. Press and hold the SILENCE button to store the new date.

Result: P 4 flashes in the PUMP INTAKE display. The message display shows SET TIME 10:30AM . Go to step 6.

5. Press the INC button.

Result: P 4 flashes in the PUMP INTAKE display. The message display shows SET TIME 10:30AM .

6. To Change the Time: (If not go to step 7.)

- a. Press the MENU button.

Result: P 4 stops flashing. The message display shows the current time with the AM or PM flashing.

- b. Press the INC or DEC button to change AM or PM.

- c. Press the MENU button.

Result: The minute flashes.

- d. Press the INC or DEC button to change the minutes.

- e. Press the MENU button.

Result: The hour flashes.

- f. Press the INC or DEC button to change the hours.

- g. Press and hold the SILENCE button to store new time.

Result: P 5 flashes in the PUMP INTAKE display. The message display shows WARNING CODES.

7. Press the MENU button.

Result: P501 shows in the PUMP INTAKE display and the message display shows the most recent error or fault code. The date and time that the error or fault code was recorded scrolls in the message display.

8. Press the INC or DEC button to scroll through 20 stored error and fault codes.

Note: FMI codes are displayed starting at P521.

9. Press and hold the SILENCE button.

Results: P 1 flashes in the PUMP INTAKE display.

10. Press the INC or DEC button to scroll through the P-codes or press the SILENCE button to exit programming mode.

CALIBRATION

The following program functions are available to view and change once the calibration password code has been entered:

C1 - Discharge Pressure Sensor Zero Calibration

C2 - Intake Pressure Sensor Zero Calibration

Refer to Calibration Programs.

Calibration Programs

The calibration password code is set from the factory as 1111.

Enter Calibration Password Code

Note: To exit the programming mode press the **SILENCE** button when the program code is flashing in the **RPM** display.

1. Press the **SILENCE** button and hold it until the **RPM** display shows four dashes – – – – and the message display shows **enter----**. Release the button.
2. Press the **MENU** button within three seconds. The **RPM** display shows the number 1000. Each time the **MENU** button is pressed the first digit scrolls up by 1. Set the first digit to the number desired.
3. Press the **SILENCE** button to move the cursor to the next digit. Press the **MENU** button to change the digit.
4. Repeat step 3 and enter the password code 1111.

Result: When a correct code is entered **C 1** flashes in the **RPM** display. The program revision **D.Sensor Set P=0?** scrolls in the message display.

Pump Sensor (Code C1 and C2)

The program for the pump pressure sensor(s) is self calibrating. There are no adjustments that can be made to the sensors. When the calibration program is activated it looks at the signal from the sensor(s), assumes this to be 0 PSI and sets the program.

Note: If there is pressure in the plumbing where the sensor is mounted this will cause the program to be calibrated to a false 0. To avoid this:

Drain the pump and plumbing to ensure there is no residual pressure before running the calibration procedure.

1. Apply power to the display module.
2. Enter the calibration password. (See Calibration Programs.)
3. Scroll to code C1 or C2, use the INC or DEC button.
4. Press the MENU button, D.Sensor or I.Sensor Set P=0? flashes.
5. Press the MENU button again to set Press=0.
6. Press and hold the SILENCE button for 3 seconds to save the setting into memory.
7. Press the SILENCE button when the program (C) code is flashing to exit calibration. Press the MENU button to enter the next program. Press the INC or DEC buttons to scroll through program codes.

WIRING

The following figures include the schematics, wiring diagrams, block diagrams, and cables.

***NOTE:** If opened, USB access port plug must be tightened to a torque of 8-10 in-lbs. Exceeding this torque value can result in damage to its water seal capability.
Warning: Flange may not fully bottom out.

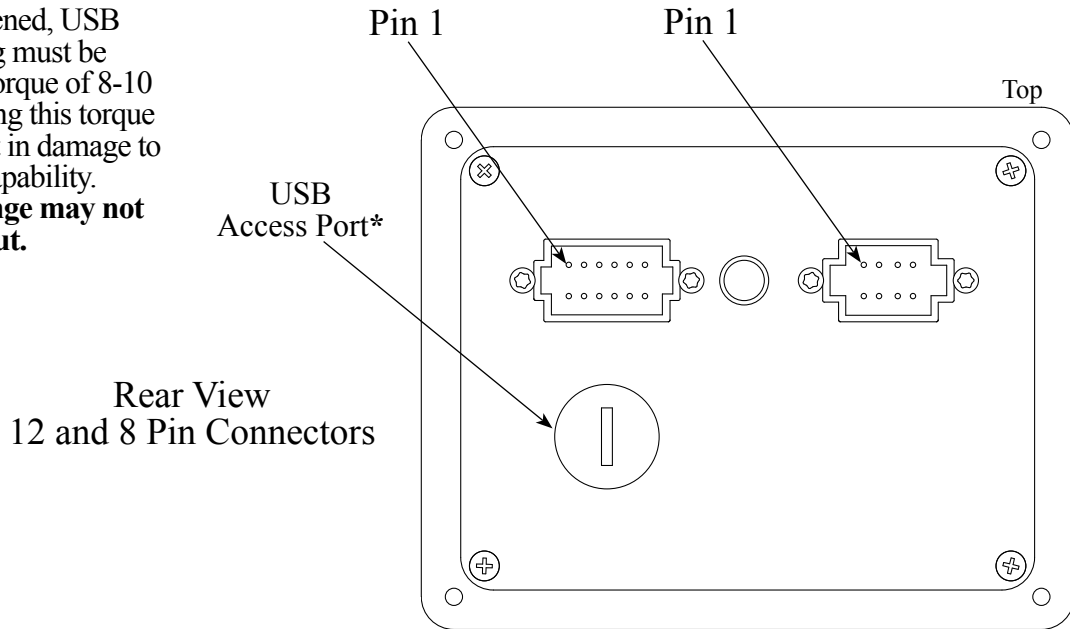

Rear View
12 and 8 Pin Connectors

12 Pin Connector/Cable

Pin	Wire Color	Description
1	White	Signal Intake Sensor
2	Black	Ground Intake Sensor
3	Red	+ 5 VDC Intake Sensor
4	White	Signal Discharge Sensor
5	Black	Ground Discharge Sensor
6	Red	+ 5 VDC Discharge Sensor
7	Yellow	CAN Shield
8	Black	J1587 (-) or CAN (L) J1939
9	Red	J1587(+) or CAN (H) J1939
10	White	Interlock Input (+ VDC)
11	Black	Ground
12	Red	Supply Voltage (12/24 VDC)

8 Pin Connector/Cable

Pin	Wire Color	Description
1	-	N/A
2	Brown	Buzzer Ground (300mA)
3	-	N/A
4	-	N/A
5	White	High Idle Active Input (+ VDC)
6	Orange	Throttle Signal To ECU
7	Black	Signal Return From ECU
8	Red	+5 VDC Reference From ECU

Figure 4. TCA200 12 and 8-Pin Connector Wiring

Connectors and Cables

When replacing an older Detroit Diesel governor, connectors with wiring are provided to utilize some of the existing harness. New wiring is required for the intake pressure sensor and engine control.

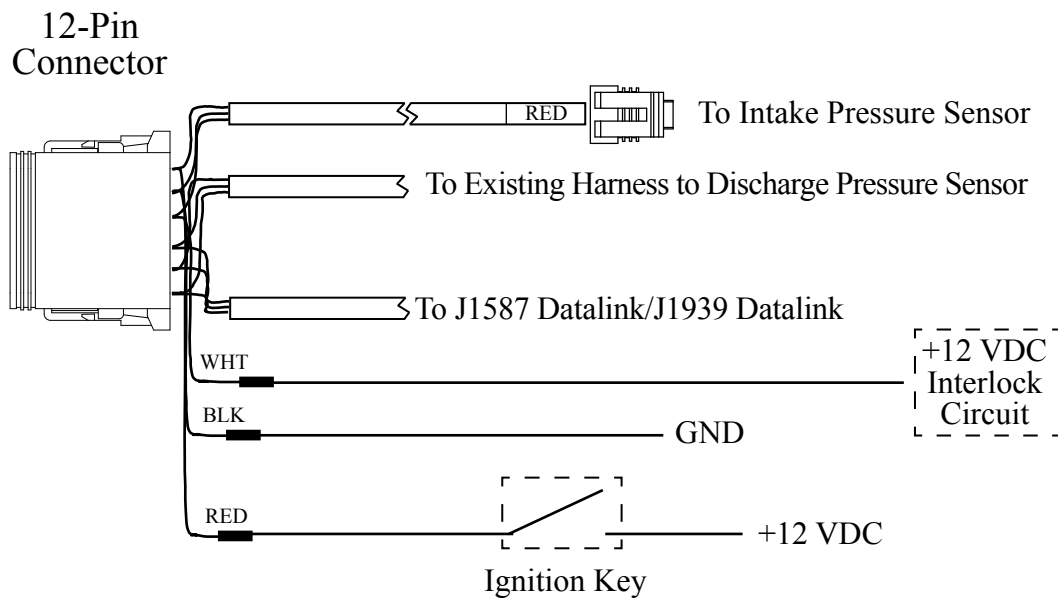

8-Pin Connector

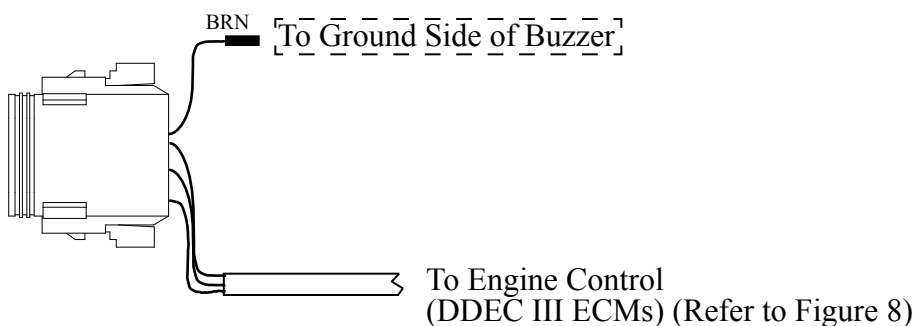
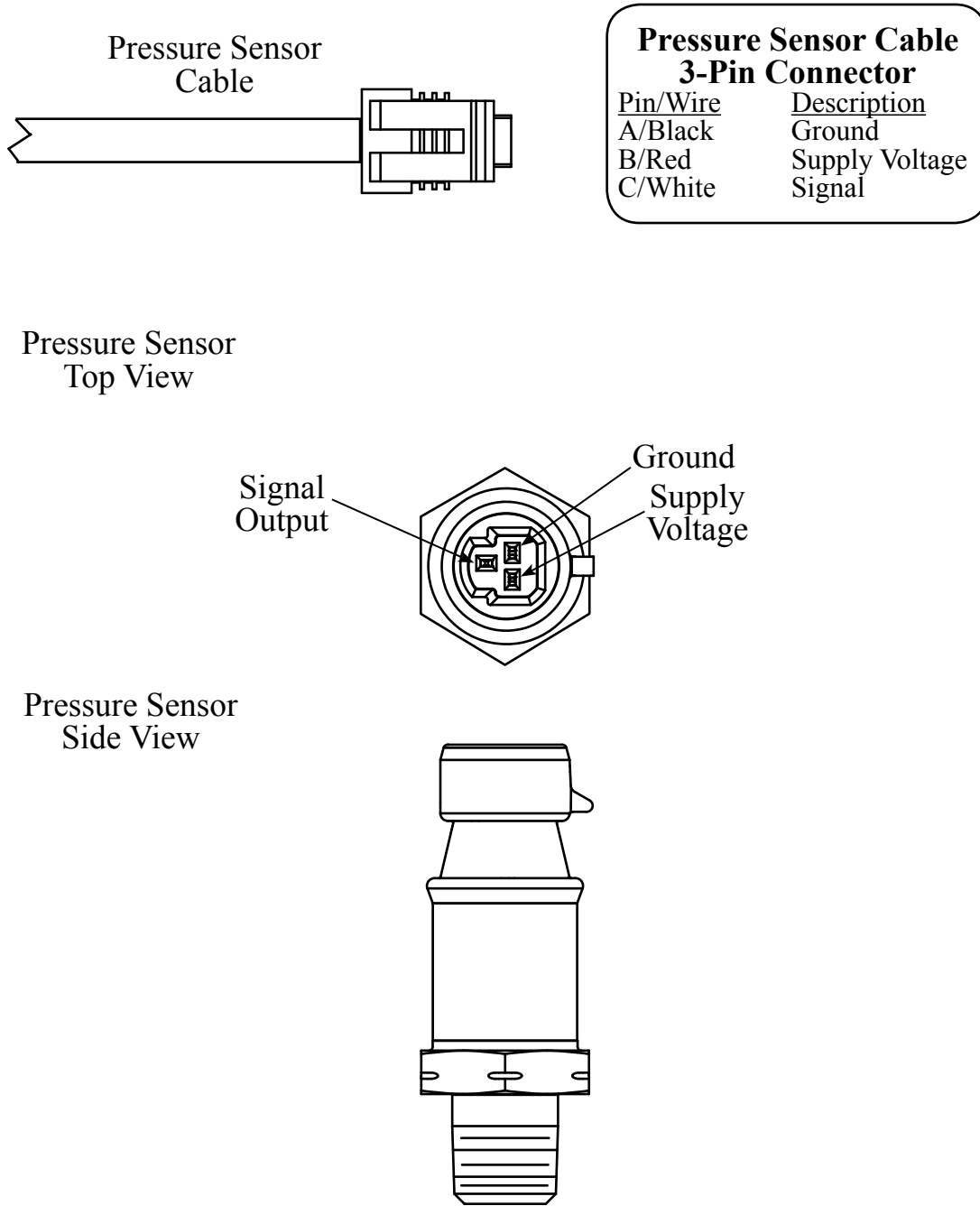

Figure 5. TCA200 Interface Wiring

Pressure Sensor



Caution: The discharge and intake pressure sensors are the same size. Ensure the correct sensor is installed on the correct manifold and the correct sensor cable is connected. Refer to Table 1.

Figure 6. Pressure Sensor Wiring

Common Diagnostic Connectors

Typical 6-pin Deutsch diagnostic connector.
Commonly found under the driver side
dashboard.

Pin A J1587 Datalink Positive
Pin B J1587 Datalink Negative

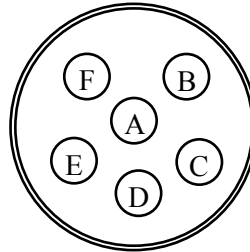

FRONT
VIEW

Typical 9-Pin Deutsch Diagnostic Connector.
Commonly found under the driver side dashboard.

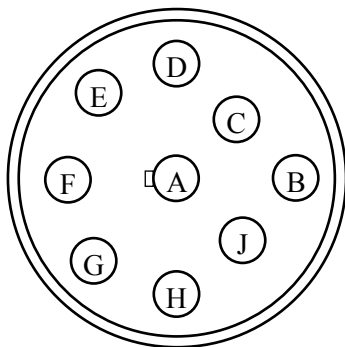

Front View

9-Pin Connector	
<u>Pin</u>	<u>Description</u>
A	Battery Ground
B	+12 VDC
C	J1939 CAN (+)
D	J1939 CAN (-)
E	J1939 Shield
F	J1587 DATA BUS (+)
G	J1587 DATA BUS (-)
H	Plug
J	Plug

Figure 7. Common OEM 9-Pin Diagnostic Connector

Detroit Diesel ECU Connections

Interface Information for DDEC III 1998 engines and older (TCA202-A00)

Connect the Engine Control extension cable to the Variable Speed Governor input on the engine ECU. There may be a 3-pin Packard connector (Variable Speed Governor Harness Connector installed by the chassis manufacturer) located behind the pump panel to plug into for the ECU connections.

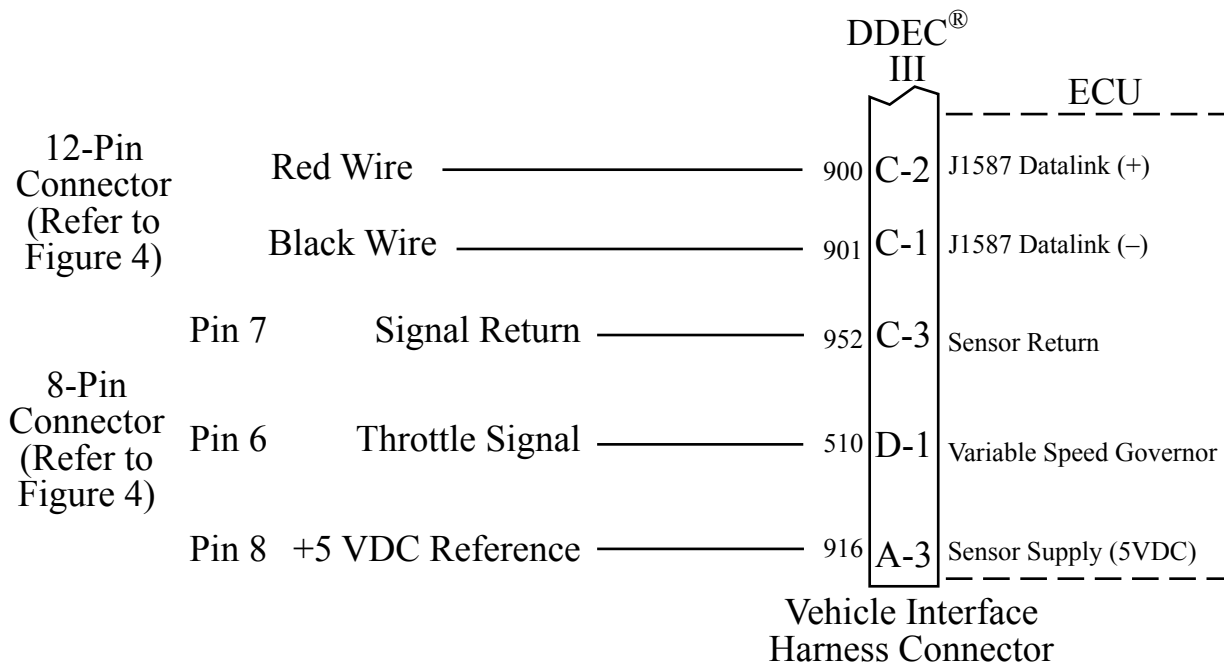

Note: J1587 Datalink connections are available on the 9-Pin diagnostics connector. Refer to Figure 7. Common OEM 9-Pin Diagnostic Connector.

Figure 8. DDEC III ECU Wiring TCA202-A00

Detroit Diesel Harness Connections

Interface Information for DDEC IV, V & VI Series Wiring (TCA202-C00)

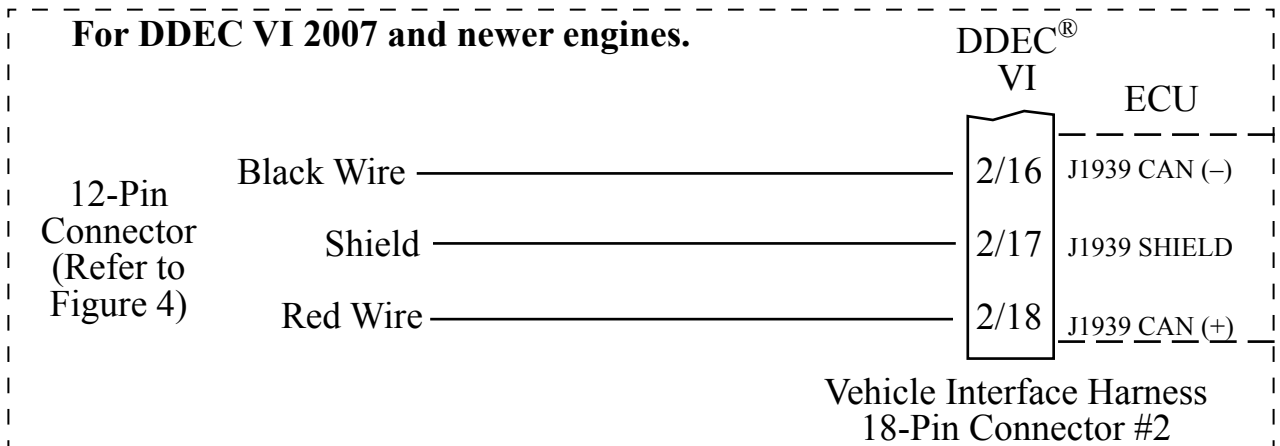
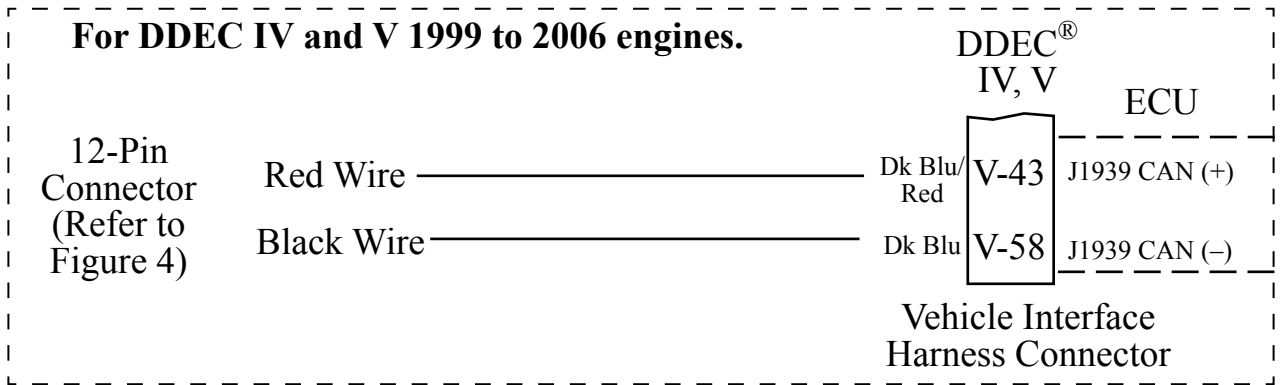

Note: Refer to Figure 4 for power and interlock connections.

Figure 9. DDEC IV, V & VI Series Wiring TCA202-C00

High Idle Wiring

The governor programming includes a high idle function. To activate the high idle provide +12 VDC to pin 5 (High Idle Active Input) of the 8-pin connector and +12 VDC pin 10 (Interlock Input) of the 12-pin connector. The high idle connection to pin 10 must be isolated from the interlock circuit using two diodes (see schematic).

Note: It is important that the connection to the Interlock Input from the High Idle circuit be isolated from the apparatus interlock wiring with the two diodes. Refer to the wiring diagram. **The pump must NOT be engaged when using the high idle function.**

The high idle is set at about 1000 RPM at the factory. (This value will vary depending on the specific engine.) To adjust this setting refer to High Idle in the Operation Section.

A High-Idle Kit is available from FRC.

Includes:

ON/OFF Switch

Indicator Light

Two Diodes

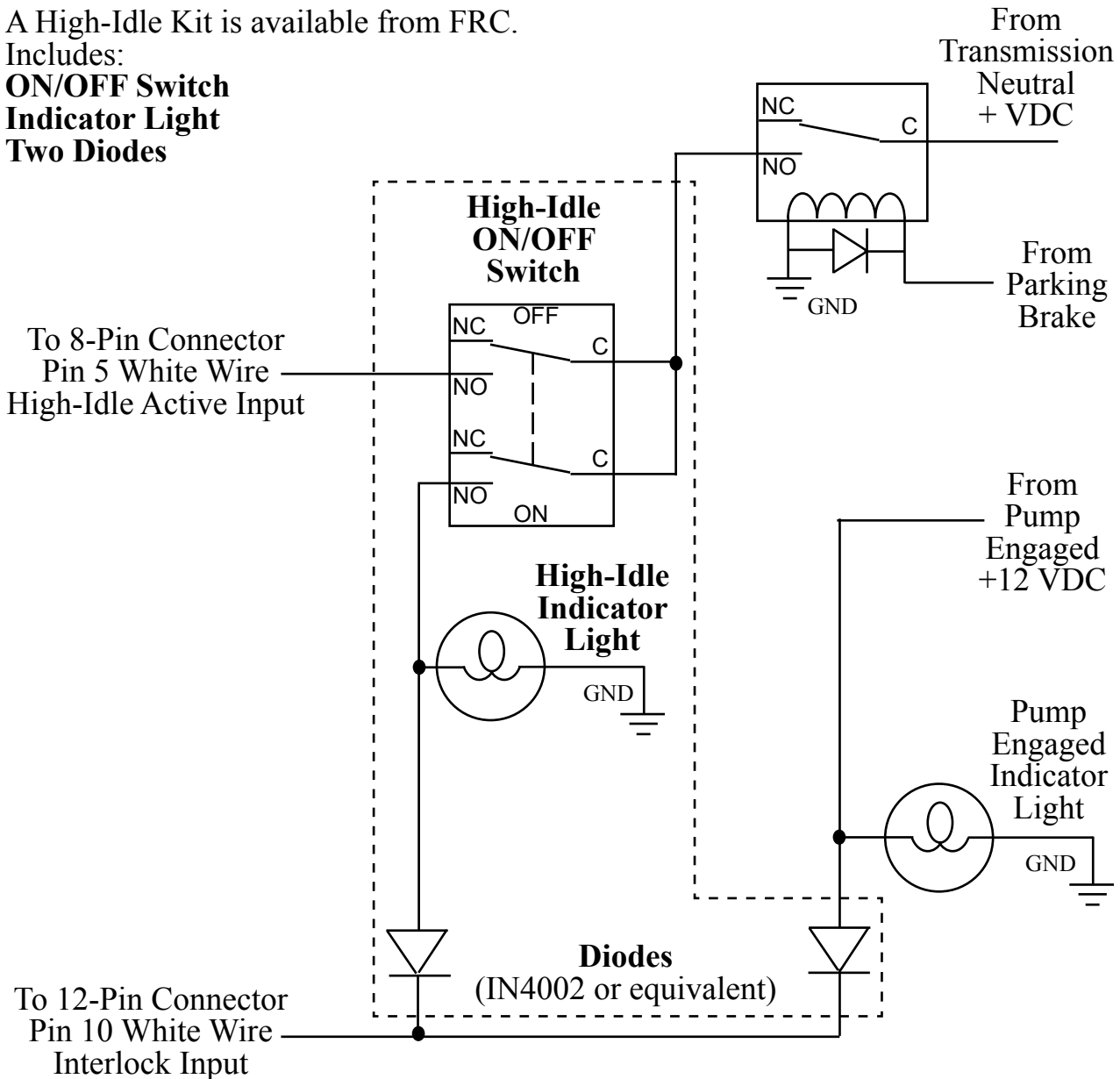

Figure 10. High Idle Wiring

FLYBACK DIODE INFORMATION

It is good engineering practice to include a flyback diode when switching an inductive load (solenoid coil, relay coil, electric motor winding, etc.). It is recommended that a flyback diode be installed on inductive devices that share a common power source/ground with a FRC governor.

Typical circuit showing a flyback diode installed across an inductive load.

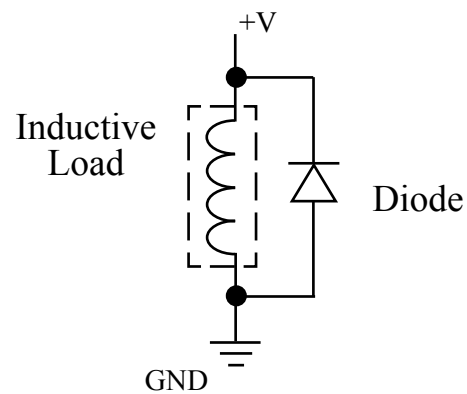

Diagram showing a flyback diode connected on a typical pump primer motor solenoid.

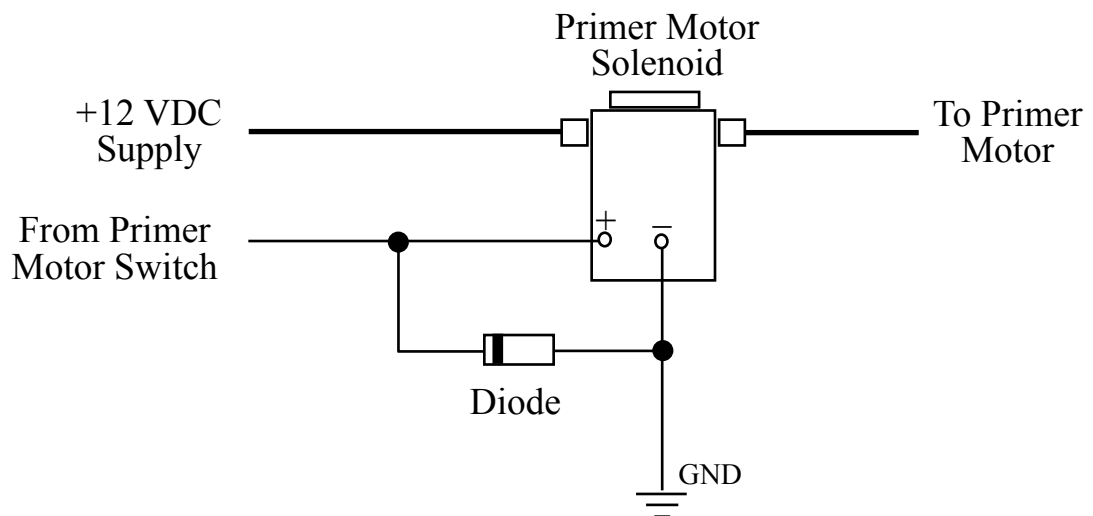

Figure 11. Flyback Diode



DANGER

PERSONAL RESPONSIBILITY CODE

The member companies of FEMSA that provide emergency response equipment and services want responders to know and understand the following:

1. Firefighting and Emergency Response are inherently dangerous activities requiring proper training in their hazards and the use of extreme caution at all times.
2. It is your responsibility to read and understand any user's instructions, including purpose and limitations, provided with any piece of equipment you may be called upon to use.
3. It is your responsibility to know that you have been properly trained in Firefighting and/or Emergency Response and in the use, precautions, and care of any equipment you may be called upon to use.
4. It is your responsibility to be in proper physical condition and to maintain the personal skill level required to operate any equipment you may be called upon to use.
5. It is your responsibility to know that your equipment is in operable condition and has been maintained in accordance with the manufacturer's instructions.
6. Failure to follow these guidelines may result in death, burns or other severe injury.



Fire and Emergency Manufacturers and Services Association, Inc.
P.O. Box 147, Lynnfield, MA 01940 www.FEMSA.org

Copyright 2006 FEMSA. All Rights Reserved