



A Safe Fleet Brand

THROTTLEXCEL

ENGINE THROTTLE with DISPLAY and MONITORING SYSTEM MODEL: ELA200



FIRE RESEARCH CORPORATION

www.fireresearch.com

26 Southern Blvd., Nesconset, NY 11767

TEL 631.724.8888 FAX 631.360.9727 TOLL FREE 1.800.645.0074

CONTENTS

Table of Contents

CONTENTS.....	2
INTRODUCTION	4
Overview.....	4
Features.....	4
Specifications	5
GENERAL DESCRIPTION	6
Controls and Indicators	8
INSTALLATION	10
Install Control Module.....	10
Install Engine Sensors.....	10
Install Buzzer	10
Install High Idle Kit	10
OPERATION	12
Throttle Control Mode	12
Governor Control Mode.....	12
Power-up.....	12
Controls.....	13
Detailed Information.....	14
High-Idle.....	15
PROGRAMMING	16
Access Password Protected Programs	18
CALIBRATION.....	20
Engine RPM (Code C3).....	21
WIRING.....	22
Connectors and Cables.....	22
Secondary Controller, Cables and Connections.....	23
Cummins Harness Connections	24
Detroit Diesel Harness Connections	25
Navistar Harness Connections	27
Navistar / International Chassis Harness Connections	28
Caterpillar Harness Connections	29
Ford Harness Connections	31
Mack Harness Connections	34
Scania Harness Connections—Type A	36
Scania BCI Harness Connections—Type D	37
Mercedes Harness Connections	38
John Deere Harness Connections	39
MAN Harness Connections	40
IVECO Harness Connections	41
High-Idle Wiring.....	42
FLYBACK DIODE INFORMATION	43

List of Tables

Table 1. Error Codes	13
Table 2. Fault Warning Codes.....	13
Table 3. Calibration Codes Quick Reference Chart.....	20

List of Figures

Figure 1. Controls and Indicators.....	9
Figure 2. Control Module Mounting Dimensions.....	11
Figure 3. Connectors.....	22
Figure 4. Connector Wiring	23
Figure 5. Cummins ELA201 Wiring.....	24
Figure 6. Detroit Diesel ELA202 Wiring.....	25
Figure 7. Detroit Diesel ELA202 Wiring Governor Control Mode.....	26
Figure 8. Navistar ELA204 Wiring.....	27
Figure 9. Navistar/International Chassis ELA204 Wiring.....	28
Figure 10. Caterpillar ELA205 Wiring	29
Figure 11. Ford 6.7L ELA206 J1939 Translator Module Wiring	32
Figure 12. Ford 6.7L ELA206 PCM Wiring.....	33
Figure 13. Mack ELA207 Wiring	34
Figure 14. Mack ELA207 Wiring Governor Control Mode	35
Figure 15. Scania ELA208 Wiring—Type A	36
Figure 16. Scania BCI ELA208 Wiring—Type D	37
Figure 17. Mercedes ELA210 Wiring.....	38
Figure 18. John Deere ELA216 Wiring.....	39
Figure 19. MAN ELA224 Wiring.....	40
Figure 20. IVECO ELA426 Wiring.....	41
Figure 21. High-Idle Wiring	42
Figure 22. Flyback Diode	43

INTRODUCTION

Overview

The ThrottleXcel is an all-in-one instrument panel that integrates a traditional style remote hand throttle with engine monitoring and display. It provides engine control as a remote throttle or it can be programmed as an engine governor.

The ELA200 models are programmed to operate in one of the following control modes dependent on requirements, engine type, and wiring.

Throttle Control Mode: In this mode the ThrottleXcel is a traditional remote engine hand throttle and provides manual control of the engine RPM.

Governor Control Mode: In this mode the ThrottleXcel is an engine governor and maintains a constant engine RPM. It eliminates the need to make throttle adjustments as the engine load changes.

RPM adjustments are made in both modes by turning the control knob. The engine can be brought down to idle quickly after operation with the touch of the red idle button.

The four LED bar graphs provide constant display of safe operating ranges for engine oil pressure, engine coolant temperature, transmission temperature, and battery voltage. They do not show exact numbers or units of measure. Detailed information is shown in the message display when the MENU button is pressed. Engine hours are also shown.

All controls and indicators are located on the front of the control module.

Features

J1939 CAN Bus for Engine Information

Manual or Automatic Control of Engine RPM

Powers Up at Engine Idle RPM

Interlock Signal Recognition with Throttle Ready LED

Return to Engine Idle With the Push of a Button

Diagnostic Capabilities

High Idle

Displays and LEDs Automatically Adjusted for Day or Night Operation

Audible Alarm Buzzer (Optional)

KPa / Bar (Optional)

Specifications

The ThrottleXcel is available in various models. Each model is programmed to interface with specific engines. All models provide the same functions, controls, and digital readouts.

Display Module

Supply Power:	12/24 VDC
Supply Current:	0.5 Amps
Dimensions:	4 5/8" Wide by 6 3/4" High

LED Bar Graphs

Oil Pressure:	10 - 100 PSI
Temperature (Engine Coolant):	150 - 240 °F
Transmission Temperature:	140 - 300 °F
Battery Voltage:	11.5 - 15.5 VDC (12 V) 23.0 - 30 VDC (24 V)

Engine Sensors (as necessary)

Engine Oil Pressure:	0 - 100 PSI, 1/8" NPTF
Engine Coolant Temperature:	100 - 250 °F, 1/2" - 14 NPT
Transmission Temperature:	140 - 320 °F, 1/8" NPTF

Audible Alarm Buzzer (Optional)

Voltage:	12/24 VDC
Volume:	96 dB

GENERAL DESCRIPTION

The ThrottleXcel model ELA200 provides a remote throttle for engine RPM control and displays for remote engine monitoring, these models are not engine governors.

The ThrottleXcel is compatible with the following engines:

ELA201 Cummins IS Series

ELA202 Detroit Diesel

ELA204 Navistar

ELA205 Caterpillar

ELA206* Ford (Governor Control Mode Not Available)

ELA207 Mack (Governor Control Mode Not Available)

ELA208 Scania

ELA210 Mercedes

ELA216 John Deere

ELA224 MAN

ELA226 IVECO

* **Note:** An adapter and cable assembly replaces the basic 8-pin cable when connecting the ThrottleXcel to a Ford (except 2011) engine.

Components

The information available on the J1939 databus varies depending on the particular engine type. Not all wires are used for all engines. Refer to the engine specific wiring diagram for interface connections. The sensors (if any) that need to be installed also vary depending on the engine.

The ThrottleXcel consist of the following components:

Control Module

Engine Oil Pressure Sensor (As Necessary)

Engine Coolant Temperature Sensor (As Necessary)

Transmission Temperature Sensor (As Necessary)

Audible Alarm Buzzer (Optional)

Cables

Contol Module

The control module is waterproof and uses 4 5/8 by 6 3/4 inches of panel space. All controls and indicators are located on the front of the control panel. (Refer to Controls and Indicators.)

Engine Oil Pressure Sensor

The oil pressure sensor is installed as necessary.

Engine Coolant Temperature Sensor

The engine coolant temperature sensor is installed as necessary.

Transmission Temperature Sensor

The transmission fluid temperature sensor is installed as necessary.

Audible Alarm Buzzer (Optional)

The optional buzzer is installed as required. A ground is provided at the 12-pin connector pin 6 to activate the buzzer (max current: 300mA). The buzzer will sound when a fault code becomes activated. *(See Table 2 for the Fault Warning Codes list/ descriptions on page 13.)*

Cables

There are three cables that connect to the control module. The 8-pin connector is for the remote throttle interface, the 12-pin connector is for the monitoring and display interface. The 6-pin connector is for the FRC datalink.

Controls and Indicators

All controls and indicators are located on the front of the control module. (Refer to Figure 1.) The displays and LEDs are automatically adjusted for day or night operation. See Operation and Programming Sections for more information.

MENU Button

Used to access stored data and program features.

Oil Pressure LED Display

Shows engine oil pressure. The LEDs are green when the pressure is within normal limits and red when it is not.

CHECK ENGINE LED, STOP ENGINE LED

Repeats the warnings from the cab.

Engine Temperature LED Display

Shows engine coolant temperature. The LEDs are green when the temperature is within normal limits and red when it is not.

Transmission Temperature LED Display

Shows transmission temperature. The LEDs are green when the temperature is within normal limits and red when it is not.

RPM Display

Shows the current engine RPM in bright red digits. It also shows error codes, stored data, and program features.

Battery Voltage LED Display

Shows battery voltage. The LEDs are green when the voltage is within normal limits and red when it is not.

SILENCE Button

Press to suppress audio alarms. Used during programming modes.

THROTTLE READY LED

This LED is on when the required interlock conditions are met to begin operations.

Message Display

The message display shows **THROTTLE ACTIVE** (or RPM setting if in governor control mode) during normal operations and warning alarms as they occur. It shows the time and date when the throttle ready LED is off. It also shows stored data and program features.

IDLE Button

When pressed immediately sets the engine RPM to idle.

Control Knob

When rotated changes the RPM. The RPM increases or decreases proportionally to the speed and direction the control knob is rotated.

SCROLL Buttons

Used during programming modes.

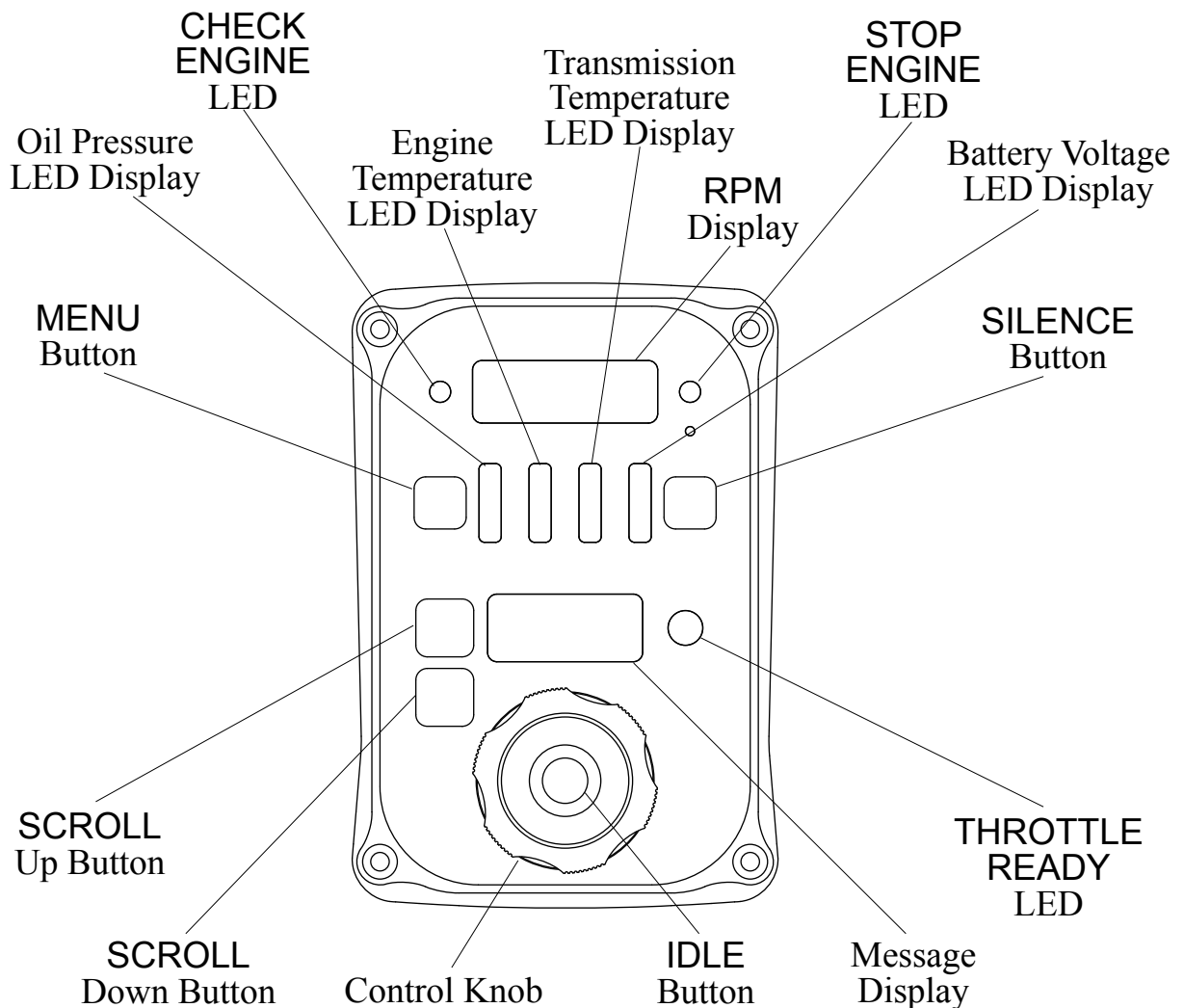

Figure 1. Controls and Indicators

INSTALLATION

Install Control Module

1. Measure and mark mounting location for control module panel cutout and mounting screw holes. Make sure there is clearance behind the panel for the module and cables before cutting holes. Refer to Figure 2 for layout and dimensions.
2. Cut out a 3 1/2 by 5 3/4 inch hole.
3. Drill four holes, clearance or tapped, for 10-32 mounting screws.
4. Place control module in position and secure with screws.
5. Connect cables at rear of the control module. (Refer to Wiring Section.)

Install Engine Sensors

For most engines, the engine throttle display receives engine RPM, oil pressure, engine coolant temperature, and transmission temperature data over the J1939 databus. Some engines do not broadcast this data over the databus and sensors may need to be installed.

Note: The ThrottleXcel may need a programming change for some sensor inputs to be recognized. If the sensor was not ordered as part of the ThrottleXcel kit you may need to contact FRC technical support for programming information.

The sensors are wired to the 12-pin connector at the rear of the control module. Refer to the Wiring Section.

Install Buzzer

Pin 6 on the 12-pin connector at the rear of the control module is provided to connect an optional buzzer. Connect the ground side of the buzzer to pin 6. Maximum current through pin 6 is 300 mA. The buzzer ordered from FRC requires a 1-1/8 inch diameter mounting hole. (Refer to the Wiring section.)

Install High Idle Kit

The high idle is activated when + VDC is provided to pin 7 (High Idle Active Input) of the 12-pin connector and pin 6 (Interlock Input) of the 8-pin connector. Refer to High Idle Wiring.

Note: It is important that the connection to the Interlock Input from the High Idle circuit be isolated from the apparatus interlock wiring with the two diodes. **The pump must NOT be engaged when using the high idle function and the THROTTLE READY LED will be off.**

Mounting holes are clearance or tapped for 10-32 screws.

Maximum Radius 1/2"

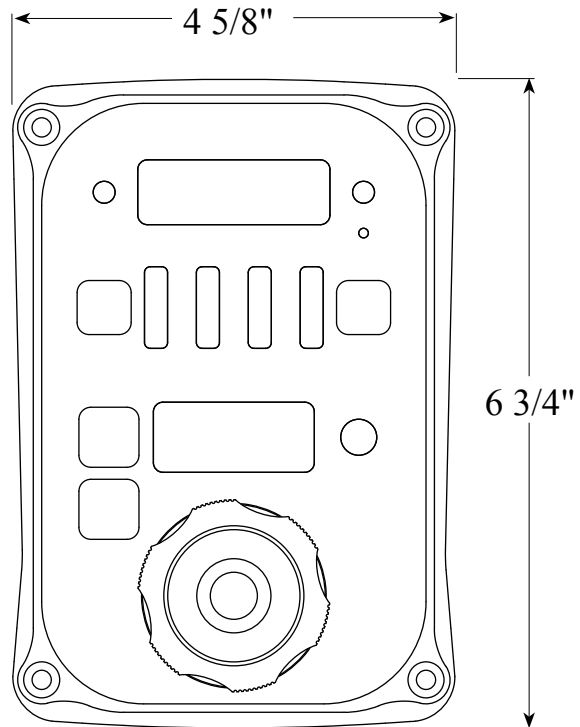
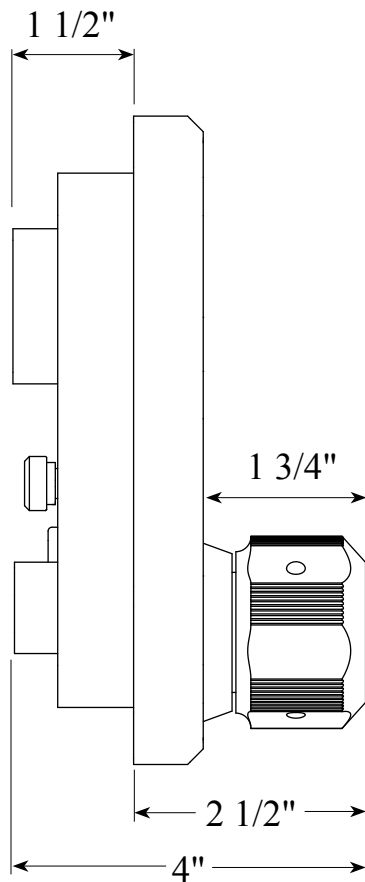
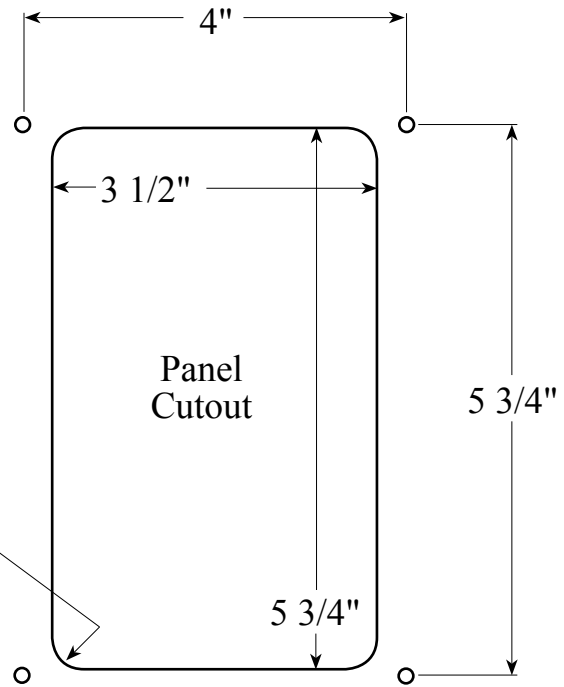

Figure 2. Control Module Mounting Dimensions

OPERATION

The ELA200 models are programmed to operate in one of the following control modes dependent on requirements, engine type, and wiring.

Throttle Control Mode

This is the factory default. In this mode the ThrottleXcel is a traditional remote engine hand throttle and provides manual control of the engine RPM. Set the control knob for a specific RPM, as the engine load changes the engine RPM may change. Changes in the ThrottleXcel output to adjust the engine RPM are made manually by turning the control knob.

The message display shows THROTTLE ACTIVE.

Governor Control Mode

This mode is programmed at installation. In this mode the ThrottleXcel is an engine governor and maintains a constant engine RPM. It eliminates the need to make throttle adjustments as the engine load changes. Set the control knob for a specific RPM, as the engine load varies the engine RPM remains the same. Changes in the ThrottleXcel output to adjust the engine RPM are made automatically and hold engine speed at the RPM setting. (Changes to the RPM setting are made by turning the control knob.)

The message display shows the RPM setting in the form: RPM 1100.

Power-up

Note: When power is applied to the ThrottleXcel the message display shows the Software Program Revision Number for five (5) seconds and then the Control Mode for two (2) seconds.

On power-up the RPM display shows engine RPM, the four LED bar graphs are green indicating readings within normal ranges, and the message display alternates between showing the date and time.

If a monitored function is not within normal parameters the display flashes, the RPM display shows an error or fault warning code and a description shows in the message display. (Refer to Table 1. Error Codes or Table 2. Fault Warning Codes.)

If one of the inputs displayed by the LED bar graphs is not within normal range the LEDs will be red.

When all necessary throttle enables are active and the interlock circuit is complete, the THROTTLE READY LED comes on and the remote throttle is ready to control the engine RPM. The control signal is set at idle regardless of the control knob position.

RPM adjustments are made in both modes by turning the control knob. The engine can be brought down to idle quickly after operation with the touch of the red idle button.

Controls

Control Knob

The control knob is used to adjust the engine RPM (or RPM setting). The ThrottleXcel senses how fast and in what direction the control knob is rotated and sends a signal to the ECM to increase or decrease the engine RPM proportionally.

If the control knob is rotated quickly; the engine RPM changes quickly.

If the control knob is rotated slowly; the engine RPM changes slowly.

- Rotate the control knob clockwise to increase engine RPM.
- Rotate the control knob counterclockwise to decrease engine RPM.
- Press the red IDLE button to immediately return the engine to idle.

Table 1. Error Codes

RPM Display	Message Display	Probable Cause
		Note: Not all inputs are used for all engines. For systems that use a datalink to pass information the datalink cable and connectors or ECM programming would be the probable cause.
E01	NO DATA	>Datalink cable not connected / connected to wrong port >Broken wire / bad connector contact on datalink cable
E02	NO RPM	Engine RPM not detected >Datalink cable not connected / connected to wrong port >Engine not running / ignition key on >Broken wire / bad connector contact on alternator cable
E04	NO OIL SENSOR	No Engine Oil Pressure Data Detected (w/separate sensor input) >Sensor cable not connected >Broken wire / bad connector contact on sensor cable >Defective pressure sensor
E07	NO ENG T SENSOR	No Coolant Temperature Data Detected (w/separate sensor input) >Sensor cable not connected >Broken wire / bad connector contact on sensor cable >Defective temperature sensor
E16	NO FRC DATALINK	>FRC datalink cable not connected / connected to wrong port >Broken wire / bad connector contact on cable

Table 2. Fault Warning Codes

RPM Display	Message Display	Description	Factory Default Setting
F01	HI BATT VOLTAGE	High Battery Voltage	15.5 V
F02	LOW BATT VOLTAGE	Low Battery Voltage	11.8 V*
F03	HI TRANS TEMP	High Transmission Temperature	300 °F
F04	LOW OIL PRESSURE	Low Engine Oil Pressure	8 PSI**
F07	HI ENG TEMP	High Engine Coolant Temperature	220 °F**
F09	ENG NOT RESPOND	Engine Does Not Respond	

* 11.8 engine running, 11.7 engine off.

** J1939 compliant—engine ECM will issue this warning.

Detailed Information

The four LED bar graphs provide constant display of safe operating ranges for engine oil pressure, engine coolant temperature, transmission temperature, and battery voltage. They do not show exact numbers or units of measure. This detailed information is shown in the message display when the **MENU** button is pressed. Engine hours are also shown.

Show Detailed Information

Note: Detailed information is a display only mode and no changes can be made to the data.

The **MENU** button allows the operator to gain access to detailed information. Each time the **MENU** button is pressed the display scrolls to show the next value.

The message display indicates the following:

ENG TEMP	### °F	(programmable for °C)
ENG OIL	### PSI	(programmable for kPa or Bar)
BATT VDC	##.# V	(programmable for 12V or 24V)
ENG HRS	#####	
TRANS T.	### °F	(programmable for °C)

The message display reverts to normal operation after 20 seconds if no buttons are pressed. When a button other than the **MENU** button is pressed, the display immediately reverts to normal operation. The **SILENCE** button should be used during operations.

High-Idle

The throttle programming includes a high-idle function. To activate the high-idle set all interlocks as called for by local SOP (normally this would include the transmission in neutral and the parking brake on). Set the High-Idle switch to ON.

Note: The pump must NOT be engaged when using the high-idle function and the THROTTLE READY LED will be off.

Change High-Idle Setting

Note: The high-idle is set at about 1000 RPM at the factory. (This value varies depending on the specific engine.)

1. With the engine running, set the high-idle switch to ON.
Result: Engine goes to High-Idle RPM.
2. Press and hold IDLE button for 3 seconds.
Result: RPM display flashes and shows the high-idle setting.
3. Keep pressing the IDLE button and rotate control knob to desired RPM.
4. Release IDLE button to store the new high idle setting.

PROGRAMMING

The following program functions are always available to view and change:

P101 - Software Program Revision Number - Read Only

P102 - Product Manufacturing Date - Read Only

P103 - Set Current Date - Read/Write

P104 - Set Current Time - Read/Write

P105 - Retrieve Fault Codes - Read Only

P106 - Engine Type Code - Read Only

Access Program Features

Note: When the program (P) code is flashing in the RPM display, press the **SCROLL** up or down button to scroll through the P-codes or press the **SILENCE** button to exit the programming mode.

1. Press the **SILENCE** button and hold it until the RPM display shows four dashes `----` and the message display shows `ENTER--- CODE`. Release the button.

Result: `P 1 0 1` flashes in the RPM display. The message display shows the program revision number `PROG REV V500.03`.

2. Press the **SCROLL** up button.

Result: `P 1 0 2` flashes in the RPM display. The message display shows the manufacturing date `MFG DATE 16JAN'15` (ddmmm'yy).

3. Press the **SCROLL** up button.

Result: `P 1 0 3` flashes in the RPM display. The message display shows the current date `SET DATE 16JAN'15`.

4. To Change the Date: (If not, go to step 5.)

- a. Press the **MENU** button.

Result: `P 1 0 3` stops flashing. The message display shows the current date with the year flashing.

- b. Press the **SCROLL** up or down button to change the year.

- c. Press the **MENU** button.

Result: The month flashes.

- d. Press the **SCROLL** up or down button to change the month.

- e. Press the **MENU** button.

Result: The day flashes.

- f. Press the **SCROLL** up or down button to change the day.

- g. Press and hold the **SILENCE** button to store the new date.

Result: `P 1 0 4` flashes in the RPM display. The message display shows `SET TIME 10:30AM`. Go to step 6.

-
5. Press the **SCROLL** up button.
Result: P 1 0 4 flashes in the RPM display. The message display shows **SET TIME 10:30AM**.
 6. To Change the Time: (If not, go to step 7.)
 - a. Press the **MENU** button.
Result: P 1 0 4 stops flashing. The message display shows the current time with the **AM** or **PM** flashing.
 - b. Press the **SCROLL** up or down button to change **AM** or **PM**.
 - c. Press the **MENU** button.
Result: The minute flashes.
 - d. Press the **SCROLL** up or down button to change the minutes.
 - e. Press the **MENU** button.
Result: The hour flashes.
 - f. Press the **SCROLL** up or down button to change the hours.
 - g. Press and hold the **SILENCE** button to store new time.
Result: P 1 0 5 flashes in the RPM display. The message display shows **NO WARNING** or **LOGGED DATA**. Go to step 8.
 7. Press the **SCROLL** up button.
Result: P 1 0 5 flashes in the RPM display. The message display shows **NO WARNING** or **LOGGED DATA**.
 8. Press the **MENU** button when it shows **LOGGED DATA** or go to step 9.
Result: 5 1 flashes in the RPM display. The fault, date, and time that the fault code was recorded shows in the message display.
 - a. To scroll through the logged fault code data, press the **SCROLL** up or down button.
 - b. Press the **SILENCE** button to exit viewing logged data.
 9. Press the **SCROLL** up or down button.
Result: P 1 0 6 flashes in the RPM display. The message display shows the engine type code that is set in the program. (Refer to the Engine Code Reference Table.)
 10. Press the **SCROLL** up or down button to scroll through the P-codes or press the **SILENCE** button to exit the programming mode.
-

Access Password Protected Programs

The following program functions are available to view and change after the password code has been entered:

Calibration Password Code 1111

C3 - Engine RPM Calibration

Refer to Calibration Section.

Enter Password Code

Note: To exit the programming mode, press the **SILENCE** button when the program code flashes in the RPM display.

1. Press the **SILENCE** button and hold it until the RPM display shows four dashes — — — — and the message display shows **ENTER--- CODE**. Release the button.
2. Press the **MENU** button within three seconds. The message display shows **CODE ENTRY**. The RPM display shows the number 1000. Each time the **MENU** button is pressed the first digit increments by 1. Set the first digit to the desired number.
3. Press the **SILENCE** button to move the cursor to the next digit. Press the **MENU** button to change the digit.
4. Repeat step 3 and enter the password code. (Calibration password is 1111.)
Result: When a correct password code is entered **C 3** for calibration or **P 3 x x** flashes in the RPM display.
5. Press the **SCROLL** up or down button when the program code is flashing to scroll through the program codes.
6. Press the **MENU** button to enter the programming mode to view and change parameter settings.
Result: The program code stops flashing. The message display shows a selectable option or a numerical value.
7. Press the **MENU** button to change a selectable option or the **SCROLL** up or down button to change a numerical value.
8. Press the **SILENCE** button to save the changes and exit the programming mode.
Result: The program code advances to the next code and flashes.
9. Repeat steps 5 through 8 as necessary.
10. Press the **SILENCE** button when the program code is flashing to exit.

This page intentionally left blank.

CALIBRATION

Three programs are available after the calibration password code has been entered:

C3 - Engine RPM Calibration

Refer to Table 5. Calibration Codes Quick Reference Chart.

Enter Calibration Password Code 1111

Note: To exit the programming mode, press the SILENCE button when the program code flashes in the RPM display.

1. Enter the password code 1111. (Refer to Programming Section.)

Result: When the correct password code is entered C 3 flashes in the RPM display. The message display shows CAL. ENG RPM.

2. Press the SCROLL up or down buttons when the program (C) code is flashing to scroll through the program codes.

Refer to specific calibration section for detailed procedures.

Note: If there is a failure during calibration the message display shows SENSOR PROBLEM.

3. Press the SILENCE button when the program (C) code is flashing to exit.

Table 3. Calibration Codes Quick Reference Chart

CODE	DESCRIPTION	MESSAGE DISPLAY	Press MENU Button Again	Press MENU Button Again
C3	Engine RPM Calibration	CAL. ENG RPM	SET RPM XXXX	

Engine RPM (Code C3)

This code is not applicable for engines with the J1939 CAN connected. To perform the following calibration, a reference tachometer is needed to verify the correct engine RPM.

1. Apply power to the display module.
2. Enter the calibration password.
3. Scroll to code **C3 CAL. ENG RPM**.
4. Press the **MENU** button to show **SET RPM**.

Result: Flashing digit is ready to be changed.

5. Set the RPM to match the reference RPM. Press the **SCROLL** up or down buttons to change the value. Press the **MENU** button to change the digit.
6. Press the **SILENCE** button to save the setting into memory.
7. Press the **SILENCE** button when the program (C) code is flashing to exit calibration. Press the **MENU** button to enter the next program. Press the **SCROLL** up or down buttons to scroll through program codes.

WIRING

The following figures include the schematics, wiring diagrams, block diagrams, and cables for the ThrottleXcel.

Connectors and Cables

For most engines the throttle display receives engine RPM, oil pressure, and coolant temperature data over the J1939 data link from the ECM. Some engines do not broadcast this data over the data link and sensors may need to be installed.

When the GOVERNOR CONTROL MODE is programmed with Cummins, Detroit Diesel, and Mercedes engines, the governor is designed to control engine throttle directly over the SAE J1939 databus. Remote throttle does not need to be enabled in the ECM and remote throttle wiring is not needed.

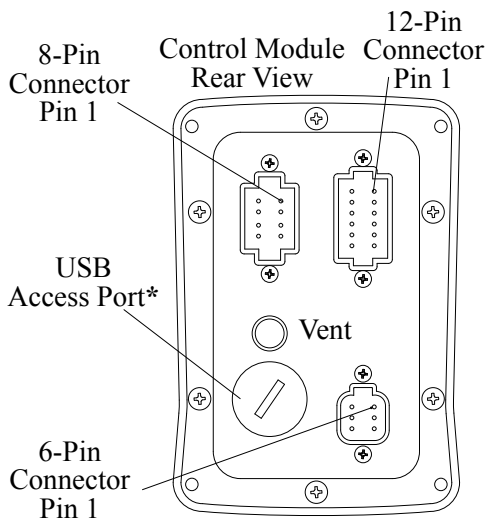

8 Pin Connector/Cable		
Pin	Wire Color	Description
1	Red	Supply Voltage (12/24 VDC)
2	Black	Ground
3	Orange	+5 VDC Reference From ECM
4	White	Throttle Signal To ECM
5	Green	Signal Return From ECM
6	Yellow	Interlock Input (+ VDC)
7	Blue	Throttle Enable Signal Output
8	Brown	Foot Pedal Signal Input

NOTE: Not all wires are used for all engines. Refer to the engine specific wiring diagram for interface connections.

***NOTE:** If opened, USB access port plug must be tightened to a torque of 8-10 in-lbs. Exceeding this torque value can result in damage to its water seal capability.

Warning: Flange may not fully bottom out.

12 Pin Connector/Cable		
Pin	Wire Color	Description
1	NC	
2	NC	
3	NC	
4	Blue	Engine Oil Press. Sensor Signal
5	Orange	Engine Temp. Sensor Signal
6	Brown	Buzzer Ground (300mA)
7	Violet	High Idle Active Input (+ VDC)
8	White	J1939 CAN (Shield)
9	Black	J1939 CAN (-)
10	Red	J1939 CAN (+)
11	Green	Transmission Temp. Sensor Signal
12	Yellow	RPM Signal

Notes:

- Not all wires are used for all engines.
- For 2011 6.7L engines and newer, the J1939 Translator Module needs to be installed.
- High idle is not available for Ford or Mack.
- When using an FRC provided engine sensor cable, the red wire is sensor signal and the black wire connects to a ground.

Figure 3. Connectors

6 Pin Connector/Cable		
Pin	Wire Color	Description
1		NC
2		NC
3		NC
4	Green	FRC Datalink (-)
5	Yellow	FRC Datalink (+)
6		NC

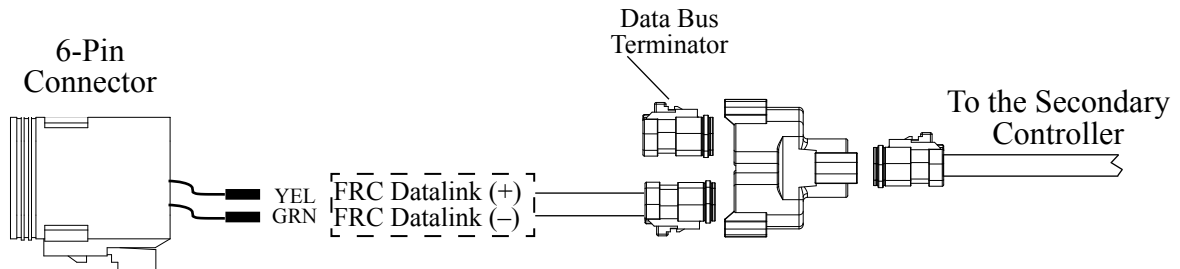

Secondary Controller, Cables and Connections

Secondary Controller 12, 8 and 6 Pin Connector Wiring

Note: The program code P303 must be set to REMOTE on the Secondary Controller control module.

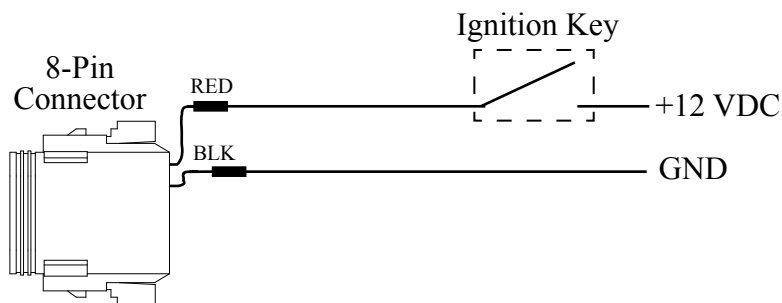
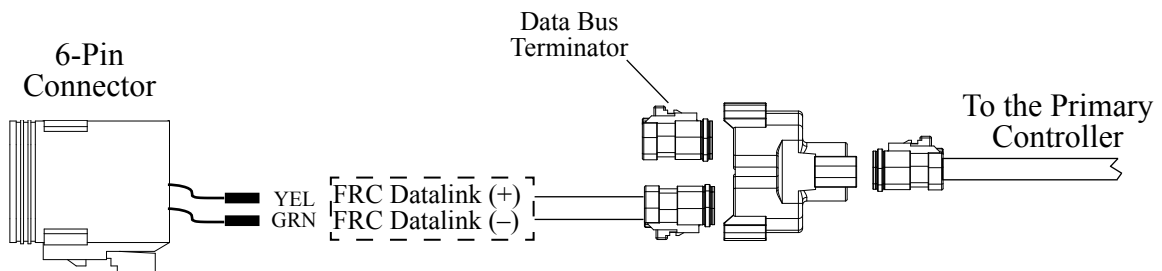

NOTE: Terminating resistor and adapters are included in the kit for connection to the primary display; no other wires are required for remote operation.

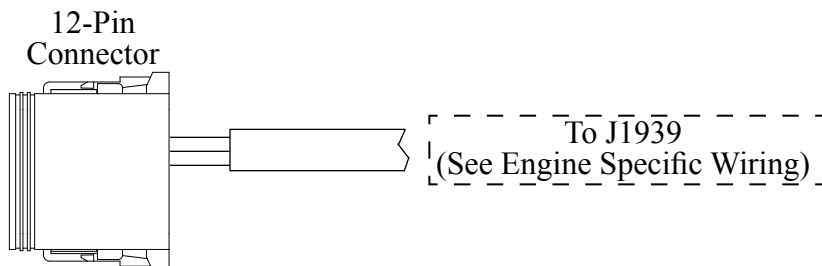

Figure 4. Connector Wiring

Cummins Harness Connections

Interface Information

The ECM Remote Accelerator (Throttle) Option has to be set to ON. The diagnostic tool cannot be used to do this, an Insight service tool must be used. Refer to an authorized dealer to program this option.

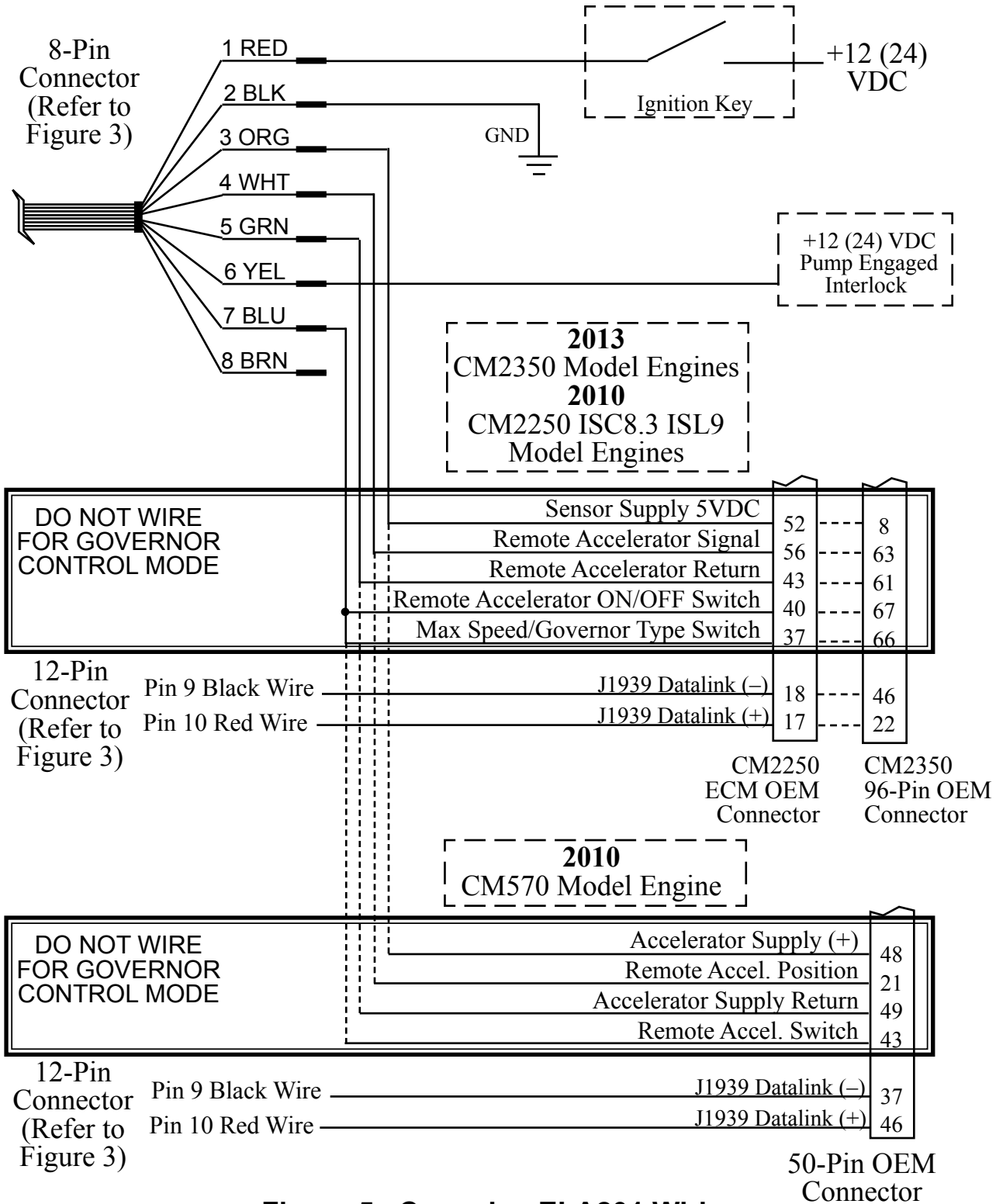

Figure 5. Cummins ELA201 Wiring

Detroit Diesel Harness Connections

THROTTLE CONTROL MODE

Interface Information

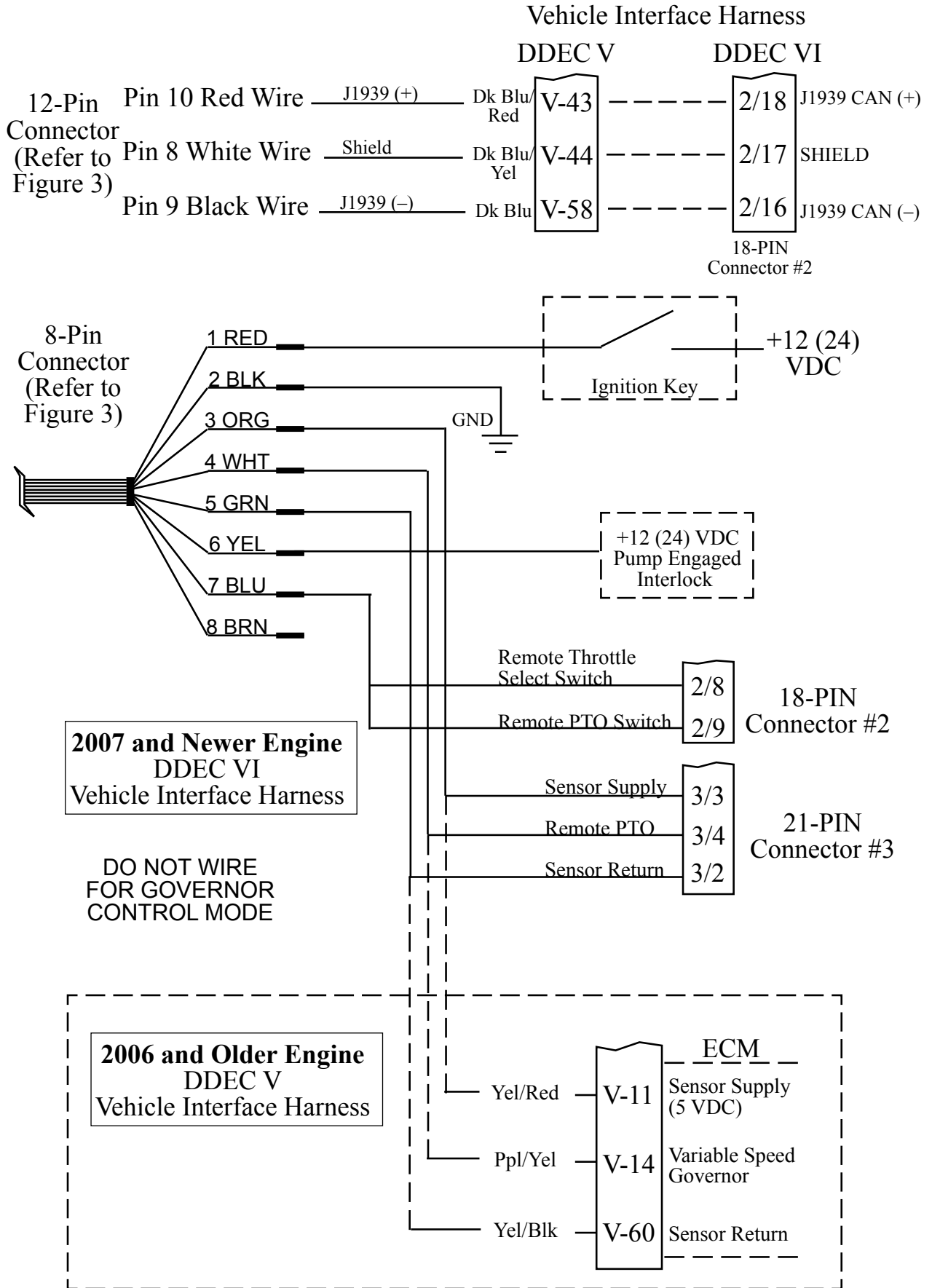

Figure 6. Detroit Diesel ELA202 Wiring

Governor Control Mode

This wiring is for use **ONLY** when the ThrottleXcel is programmed for the **GOVERNOR CONTROL MODE**.

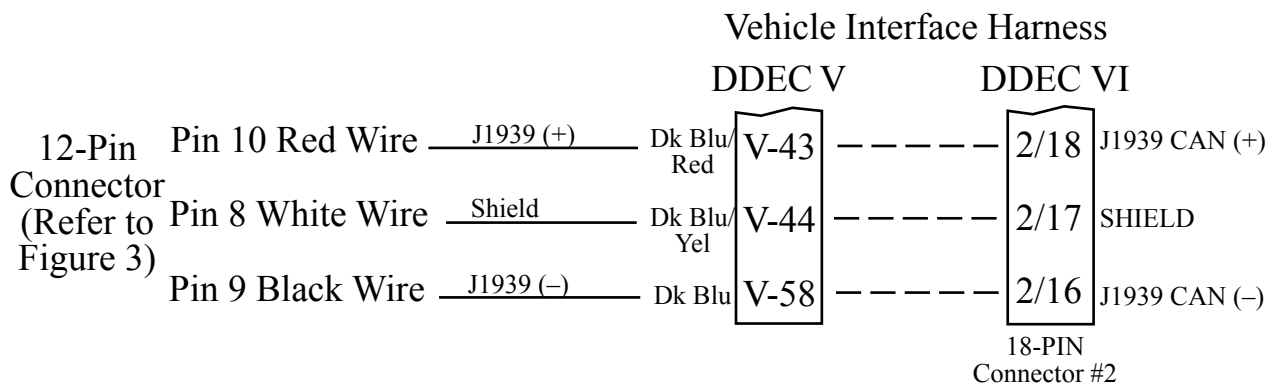

Figure 7. Detroit Diesel ELA202 Wiring Governor Control Mode

Navistar Harness Connections

Interface Information

The ECM must be programmed for a remote throttle input. When using code or 12VXY, 12VZA, or 12VZB the following parameters need to be set:

- PTO-REMOTE-PEDAL to 1-Yes; PTO-REM-PEDAL-RTZ to 1-RTZ-not;
- PTO-DISABLE-CAB-INTERFACE to 1-Yes; DRIVELINE-MODE to 1

Note: Check the engine code to verify the program setting (for J1939 control use 4C and for voltage control use 4D). Wire accordingly or change the code.

Note: Refer to Figure 4. Connector Wiring 8-Pin connector for power and interlock wire connections.

J1939 CAN Bus Control 12VXY 2010 and Newer MAXXFORCE 11 and 13 Engines

This wiring is for use **ONLY** when the ThrottleXcel is programmed for the **GOVERNOR CONTROL MODE**

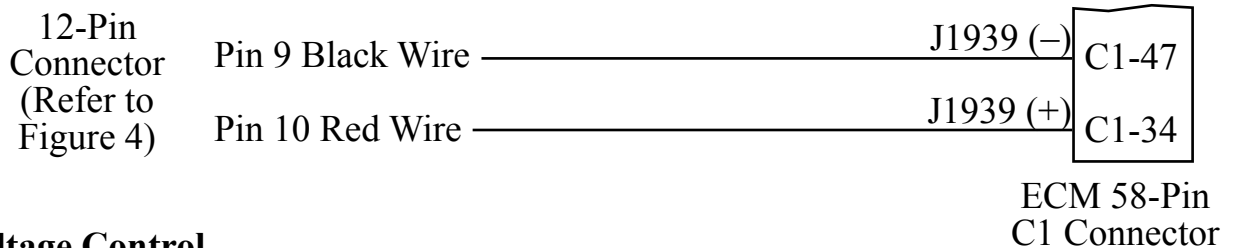

Voltage Control Post 2007 MAXXFORCE 7, DT, 9, 10, 11, and 13 Engines

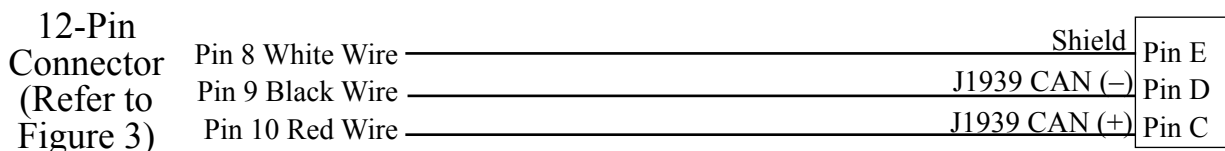
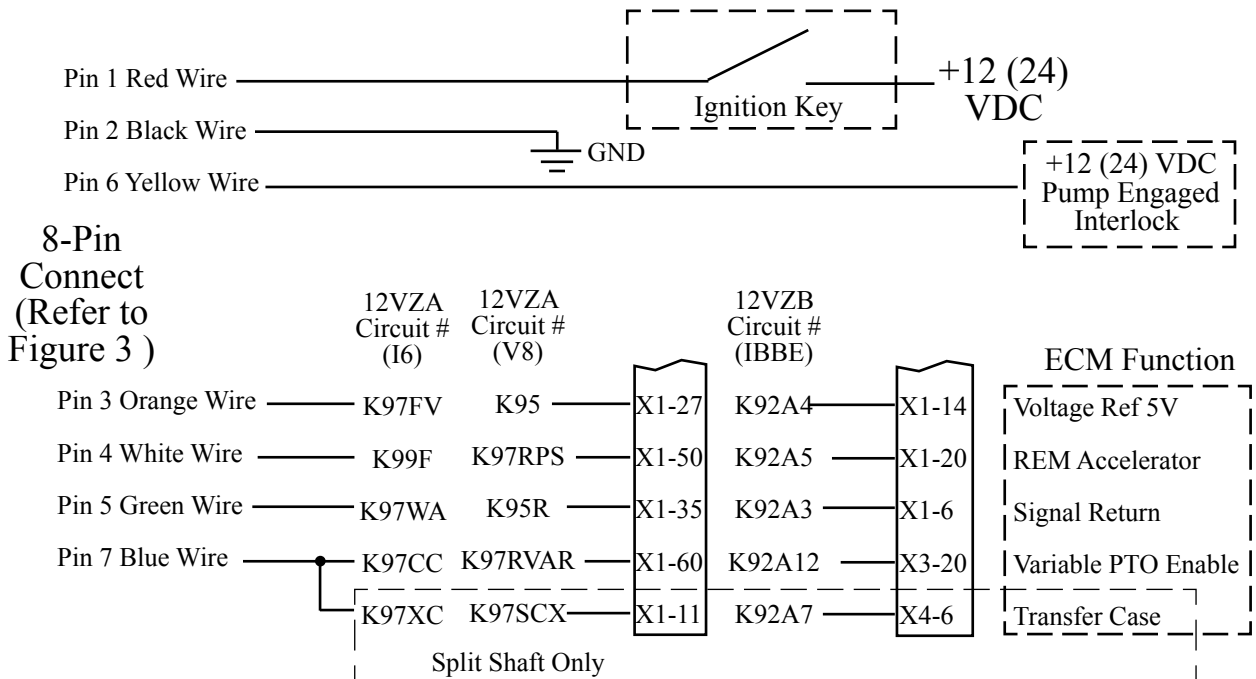

Figure 8. Navistar ELA204 Wiring

Navistar / International Chassis Harness Connections

Interface Information

Note: This function is not available on custom chassis, refer to Figure 8.
Navistar ELA Wiring.

Vehicles must be equipped with an Electronic System Controller (ESC) and have the Body Builder J1939 Datalink available.

Remote Engine Speed must be set to ON (Feature Code 0595AHA)

Connect the Body Builder J1939 Datalink to the FRC Datalink for engine control as shown below.

This wiring is for use **ONLY** when the ThrottleXcel is programmed for the **GOVERNOR CONTROL MODE**.

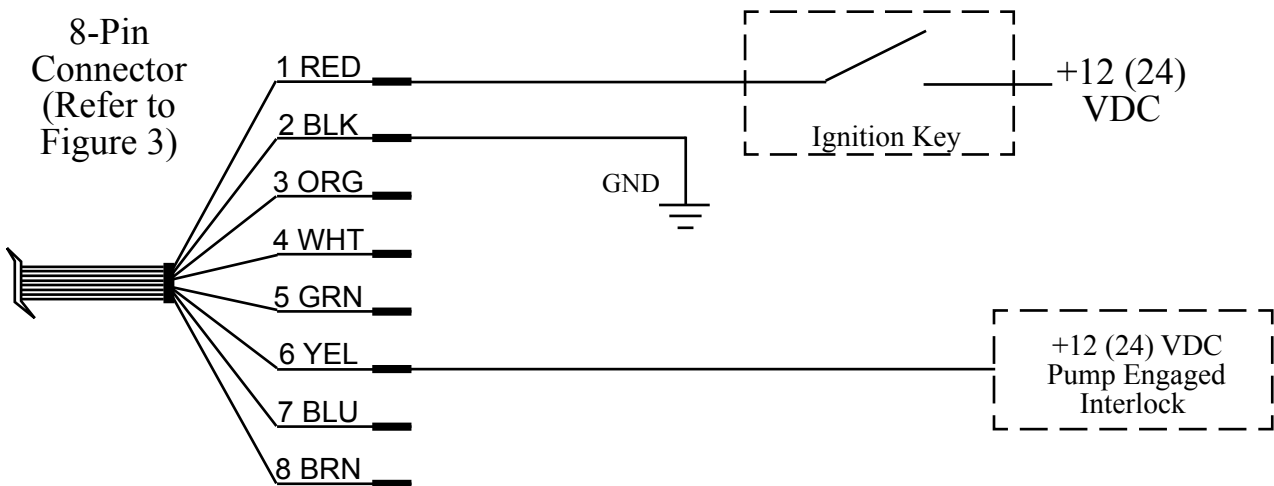

Engine Control Output

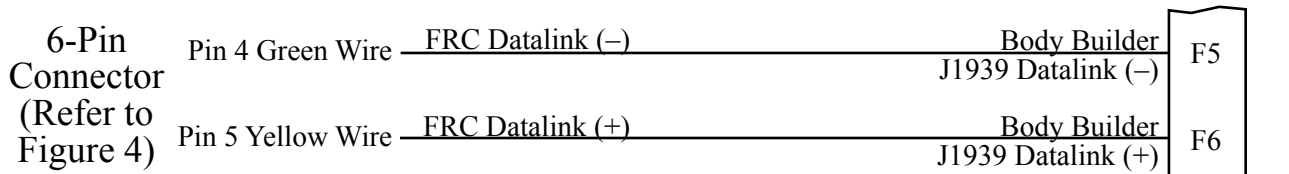

Note: The Body Builder J1939 Datalink is for engine control, the J1939 CAN Bus provides engine information to the governor.

Engine Information Input

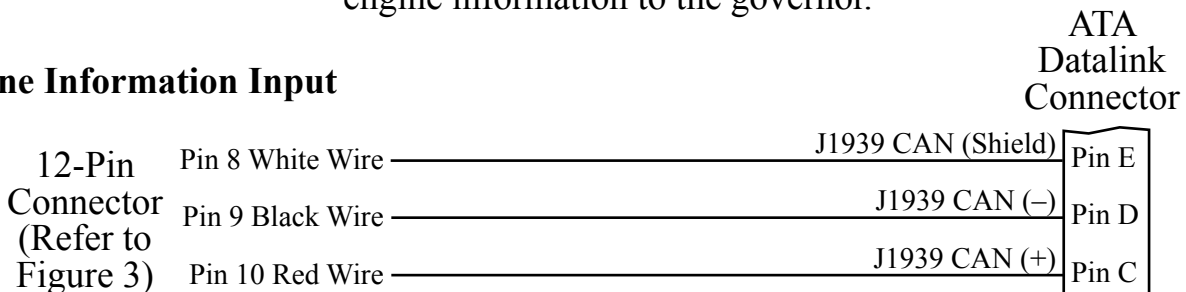

Figure 9. Navistar/International Chassis ELA204 Wiring

Caterpillar Harness Connections

Interface Information

The parameter settings for PTO Configuration are programmed to Remote Throttle or Remote Throttle with J1939 Speed Command.

ECM software with a Personality Module release date of May08 for C7, C9, C13, C15 engines, has the Remote Throttle with J1939 Speed Command setting available. This setting allows the engine speed to be controlled during PTO operations by a J1939 compliant device.

Refer to an authorized dealer to program one of these options.

C7, C9, C10, C11, C12, C13, C15 Engine Interface

Engines with 70-pin OEM connector.

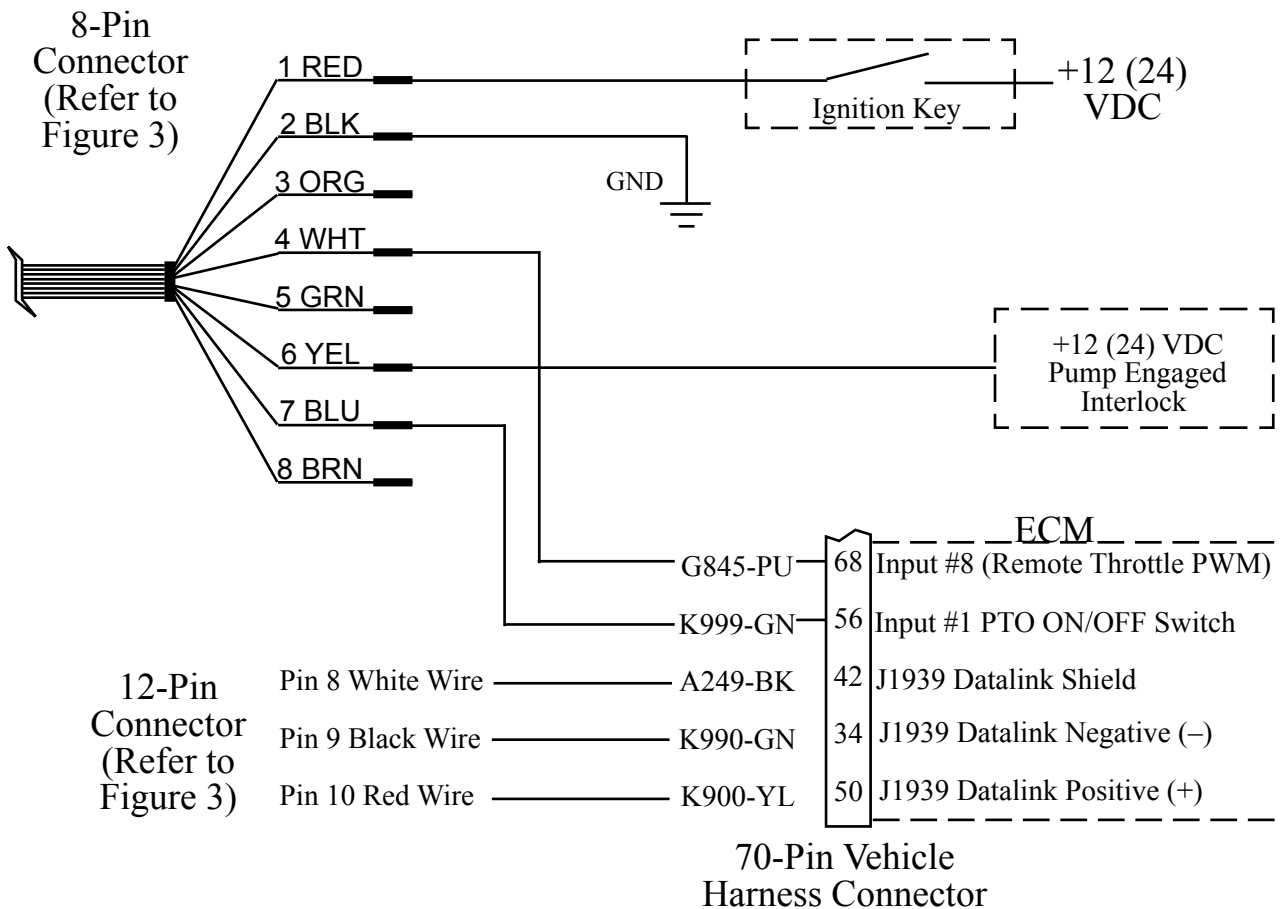
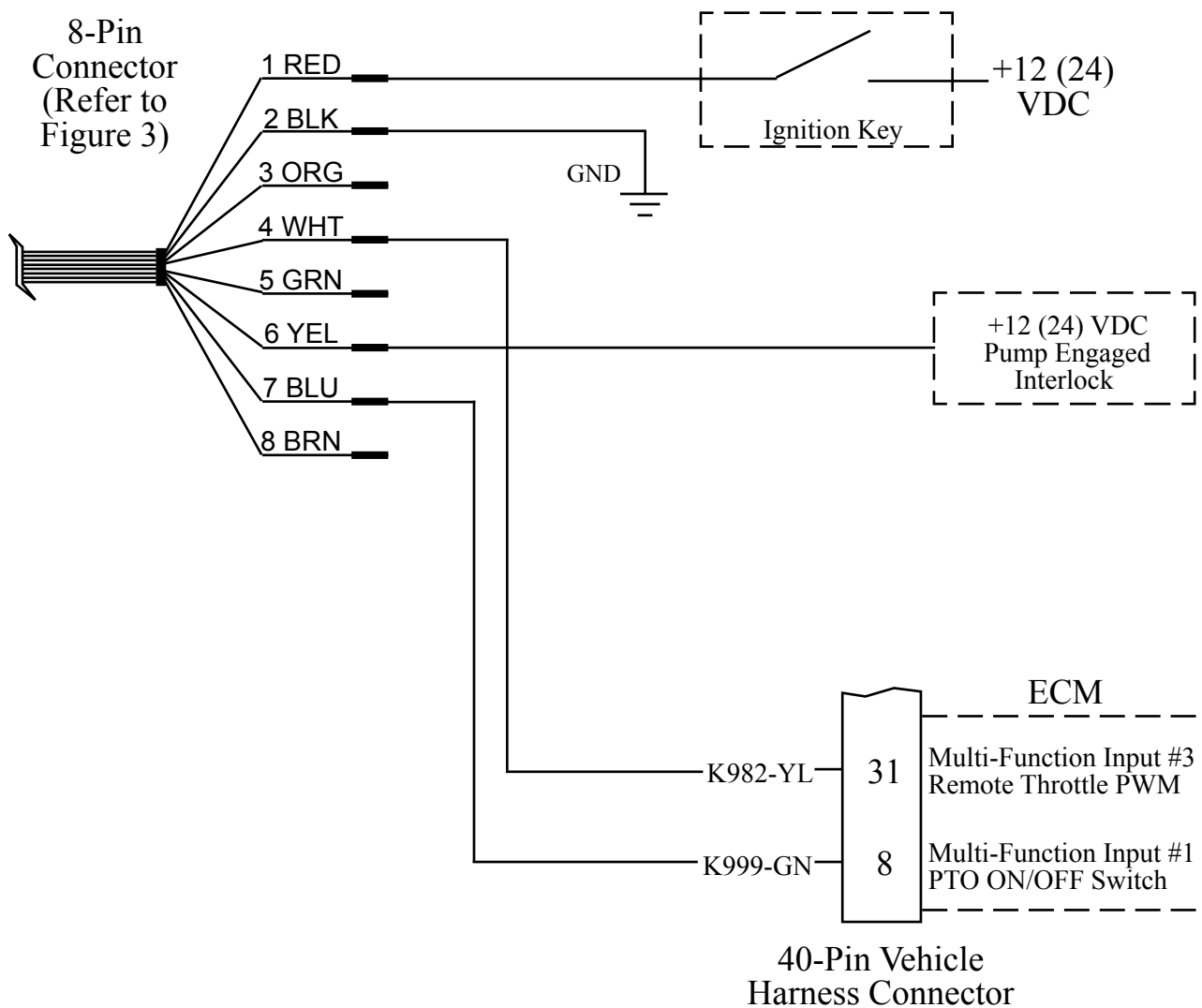

**Figure 10. Caterpillar ELA205 Wiring
(Sheet 1 of 2)**

C10, C12 Engine Interface

Engines with 40-Pin OEM connector.

Note: Refer to 12-Pin connector Figure 3 for separate sensor and RPM connections.



**Figure 10. Caterpillar ELA205 Wiring
(Sheet 2 of 2)**

Ford Harness Connections

2011 Model F-250/350/450/550 - 6.7L Diesel Engines

J1939 Interface Information

A J1939 CAN input is required to provide engine information to the ThrottleXcel. The Ford vehicle CAN Bus information needs to be interpreted. A J1939 Translator Module with a harness to connect it to the ODB-II connector must be installed.

Note: The ODB-II connector and wiring is accessed under the dash.

There are two scenarios:

- I. The J1939 Translator Module is installed as a component with governor kit (no Seat Belt Monitoring System is installed).

Install the J1939 Translator Module and the ODB-II interconnecting harness (provided with the throttle kit). A 2-Pin connector is provided for the wires to ThrottleXcel.

- II. The J1939 Translator Module is installed as part of the NFPA1901 compliant Seat Belt Monitoring and VDR System.

The Translator Module/ODB-II/VDR harness is under the driver side dash. A T-cable (provided with the governor kit) needs to be installed at the 4-Pin connector that is between the harness and the VDR.

Stationary Elevated Idle Control (SEIC) Interface Information

Note: Access wires for SEIC are located in cabin, tagged and bundled above the parking brake pedal assembly behind datalink connector.

SEIC is used in two modes: stationary and split shaft. The ThrottleXcel provides a variable RPM control to the Ford Power train Control Module (PCM) when all enabling conditions are met. Refer to Figure 13 Ford 6.7L ELA PCM Wiring.

SEIC Enablers: Parking brake applied; Foot off of service brake; Vehicle in park; Foot off of accelerator pedal; Vehicle speed is 0 mph (stationary); Engine at a stable base idle speed.

Note: Do not press the accelerator or service brake pedal when engaging the fire pump, this prevents the switch into SEIC.

Install the J1939 Translator Module with the ODB-II Interconnecting Harness or Install the T-cable between 4-Pin connectors.

To install the J1939 Translator Module with ODB-II harness, read and follow the installation instructions provided with the Translator Module kit.

Note: The TEST pad on the module circuit board has to be held at ground when the harness connector is plugged into the J1 connector.

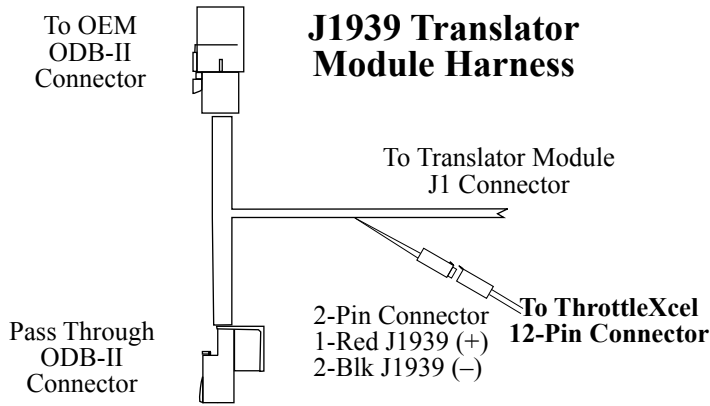

J1939 Translator Module

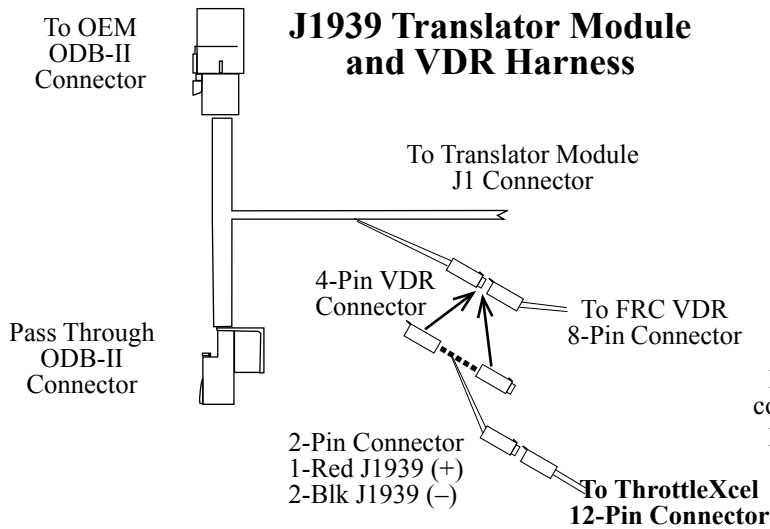
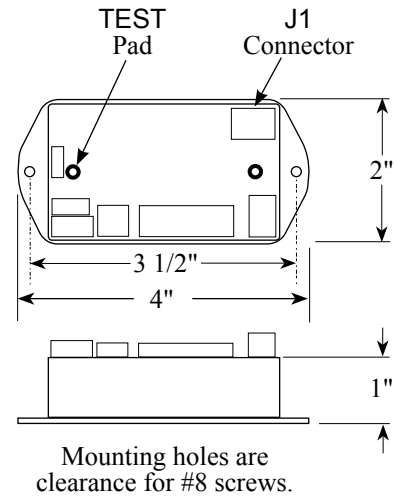

Disconnect VDR harness 4-Pin connector and connect the T-cable provided with the governor kit.

Translator Module Harness to Governor

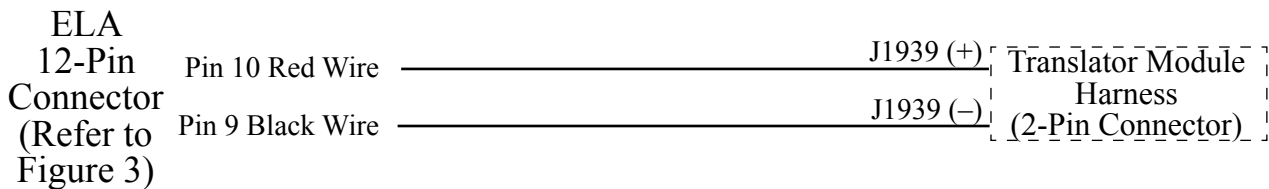

Note: Refer to Figure 3. Connector Wiring for ThrottleXcel power and interlock wire connections.

Figure 11. Ford 6.7L ELA206 J1939 Translator Module Wiring

2011 Model F-250/350/450/550 - 6.7L Diesel Engine Stationary Elevated Idle Control (SEIC)

Note: Do not press the accelerator or service brake pedal when engaging the fire pump, this prevents the switch into SEIC.

Note: Refer to Figure 3. Connector Wiring for power and interlock wire connections.

Access wires for SEIC are located in cabin, tagged and bundled above the parking brake pedal assembly behind datalink connector.

Stationary Mode

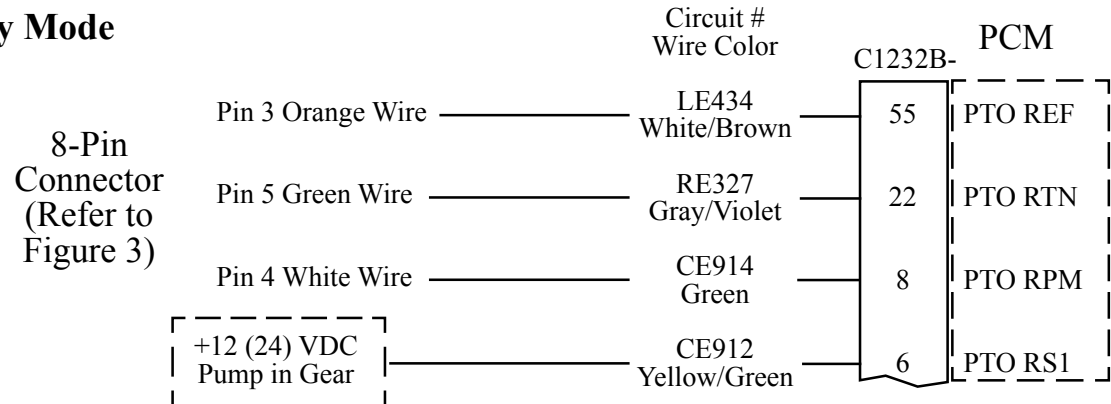

Split Shaft Mode

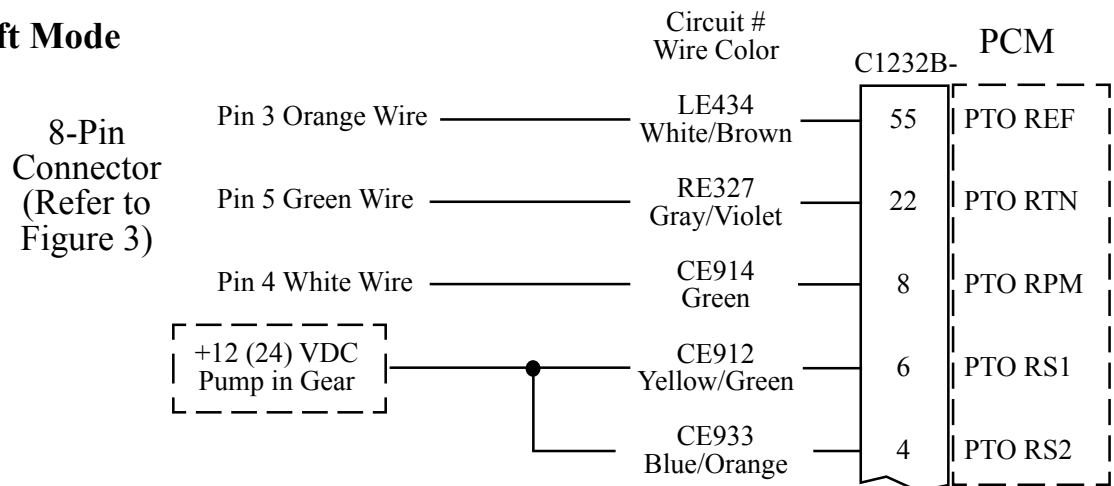

Split Shaft Mode is activated by applying supply voltage to both the PTORS1 and PTORS2 PCM circuits simultaneously.

1. Assure engine is running and fully warmed-up.
2. Apply parking brake.
3. Transmission in neutral to disengage drive wheels.

4. With foot off brake and accelerator, switch Split-Shaft PTO on.

5A. **Only for MY 2011-2012:* **Without pressing the brake, shift transmission into drive.** If vehicle unexpectedly lurches or moves, immediately press brake pedal and shift transmission into park or neutral to secure vehicle.

5B. **Only for MY 2013:* **While pressing the service brake, shift transmission into drive.**

6. Engage PTO load.

NOTE: **Refer to Ford SVE Bulletin Q-180R4*

Once the system enablers are met voltage may be added to the SEIC system for activation.

If power is applied prior to the enablers being met, a system error may occur, and the SEIC system will have to be reset.

If an SEIC disabler occurs the engine requires a change-of-state, meaning the operator is required to turn off voltage to the PTO-Request circuit, and back on again to re-invoke SEIC and PTO operation.

Figure 12. Ford 6.7L ELA206 PCM Wiring

Mack Harness Connections

Interface Information

The 8-Pin cable needs to be wired to the cab foot throttle harness. Use a voltmeter to determine which pins are 5 V Reference and Engine Control Signal.

The engine control signal will be 0.7 volts at idle and rise to approximately 3.8 volts as the foot pedal is pressed.

Note: Refer to 12-Pin connector Figure 3 for separate sensor and RPM connections.

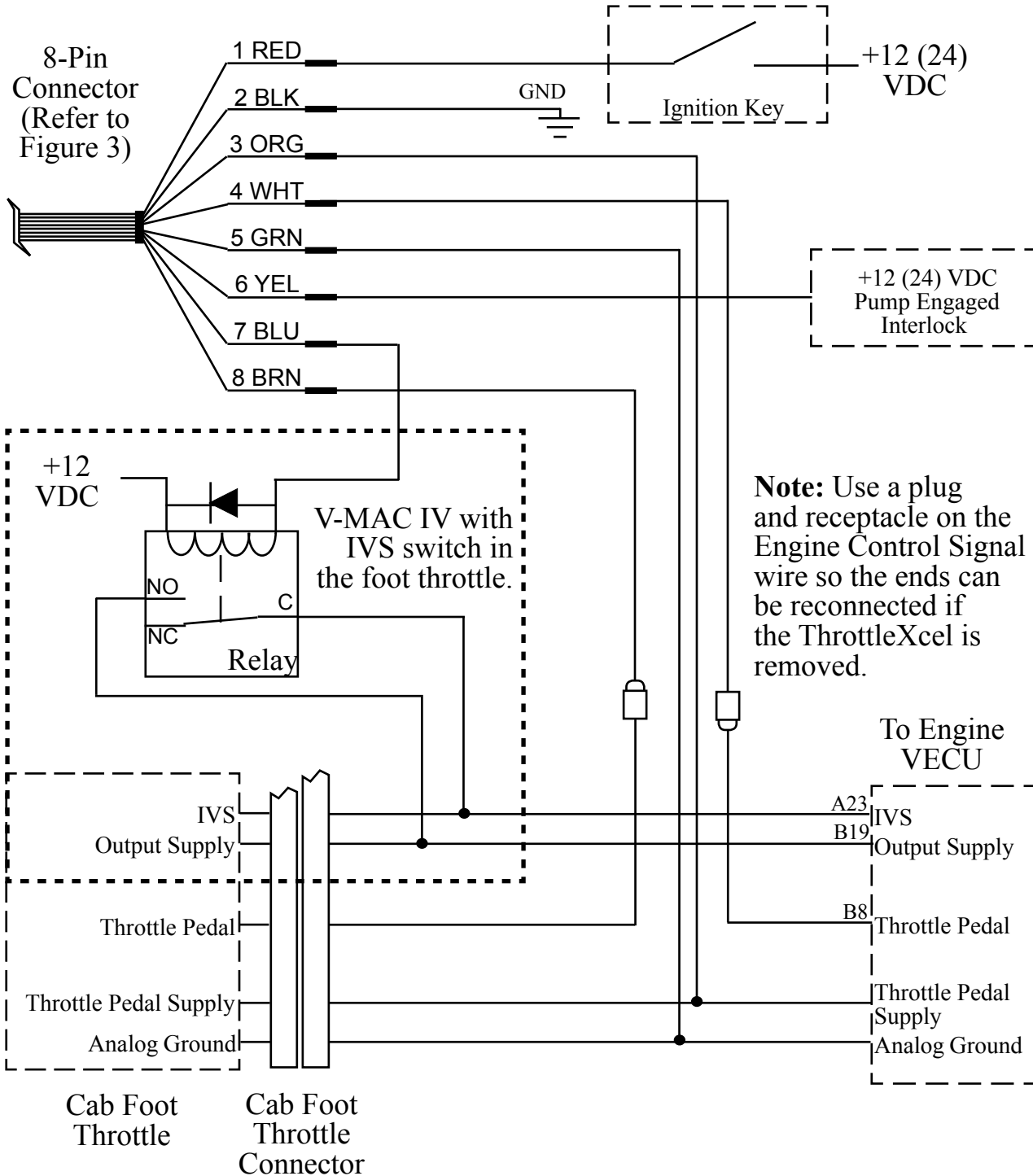

Figure 13. Mack ELA207 Wiring

Governor Control Mode

This wiring is for use **ONLY** when the ThrottleXcel is programmed for the **GOVERNOR CONTROL MODE**.

For V-MACK IV 07 and newer, the governor is designed to control engine throttle directly over the SAE J1939 databus.

J1939 CAN Bus Control

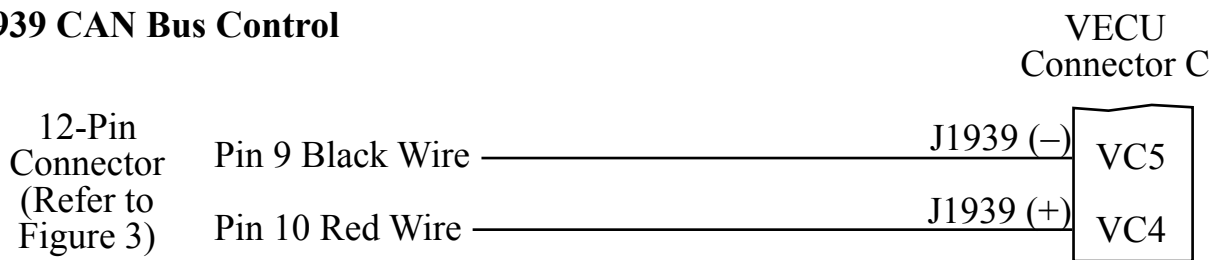
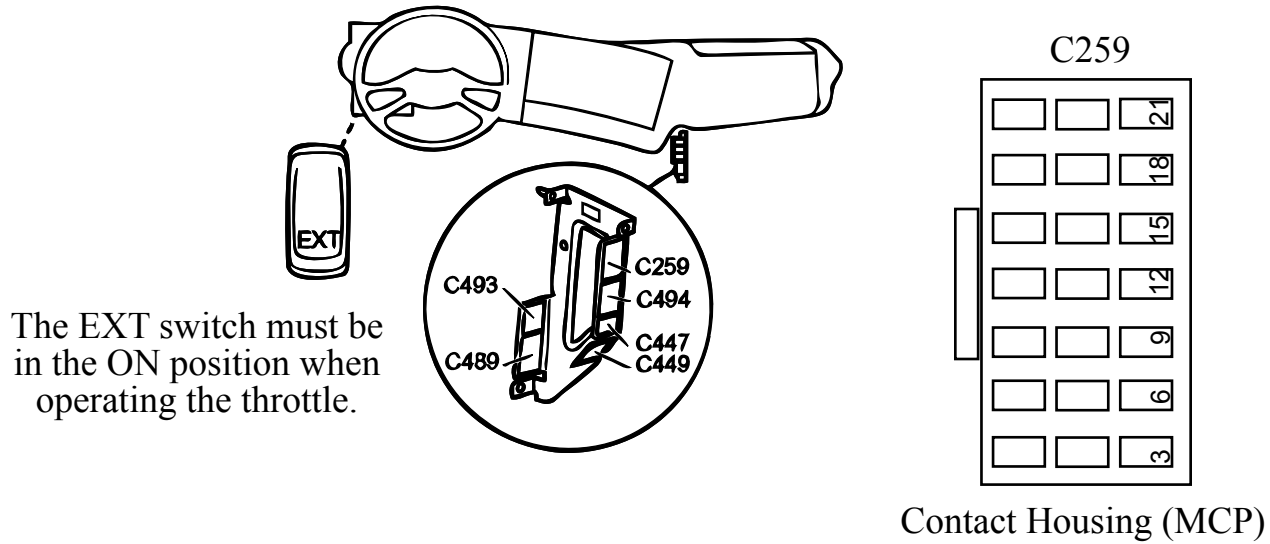

Figure 14. Mack ELA207 Wiring Governor Control Mode

Scania Harness Connections—Type A

Interface Information

For use on P, R, and T-series trucks equipped with a bodywork control unit (BWS). Connector C259 is available on all vehicles ordered with any of the bodywork options. It is located on the plate for the electrical bodywork interface for body builders. Connector C259 is white and has 21 pins. (February 2005 to 2015.)



The EXT switch must be in the ON position when operating the throttle.

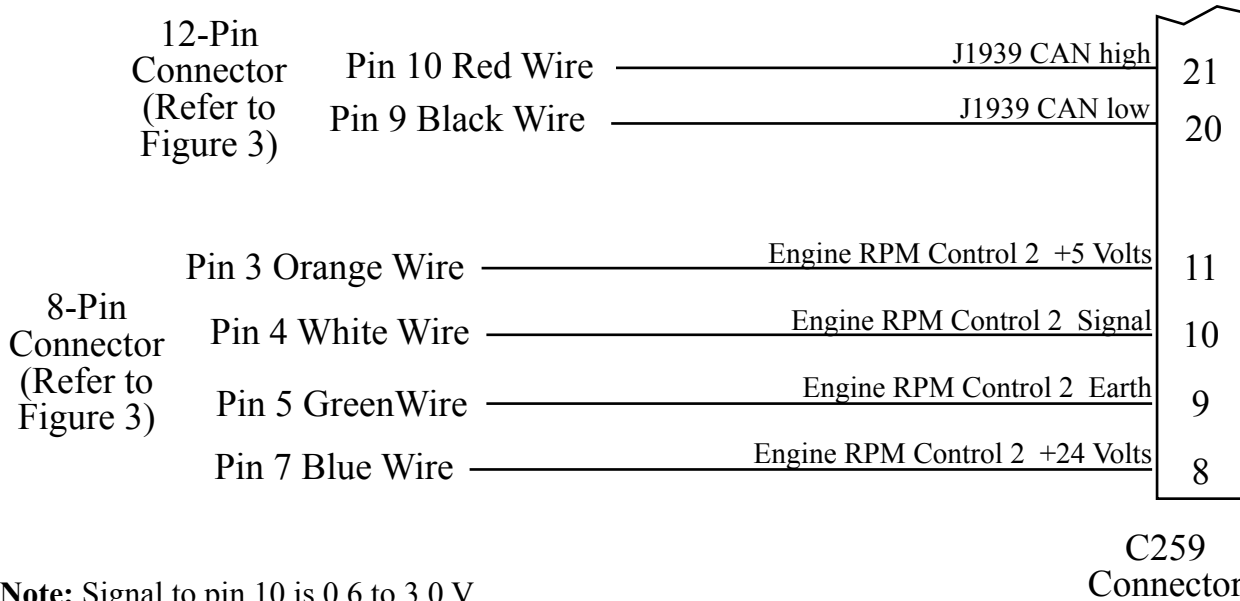

Note: Signal to pin 10 is 0.6 to 3.0 V

Figure 15. Scania ELA208 Wiring—Type A

Scania BCI Harness Connections—Type D

Interface Information

For use with BCI (Bodywork Communication Interface) module.

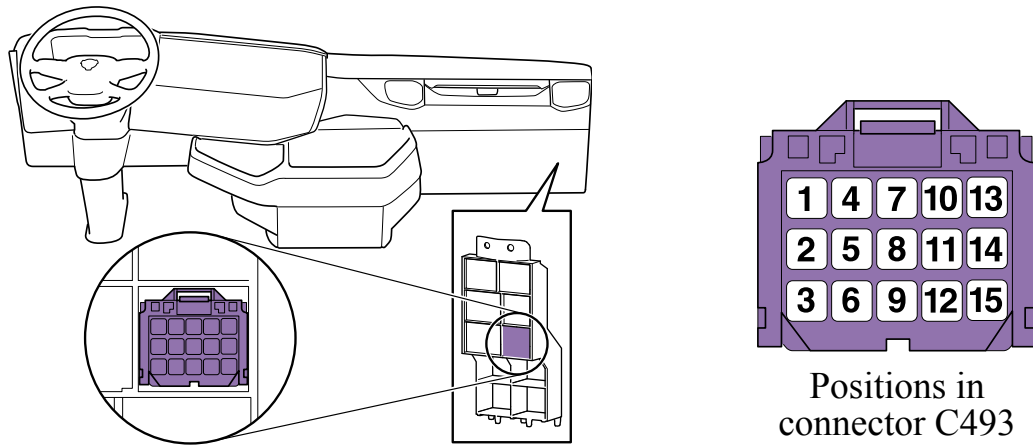

Connector C493 is located in the bodywork console.

Note: Refer to Figure 3. ELA Connector Wiring for power and interlock wire connections.

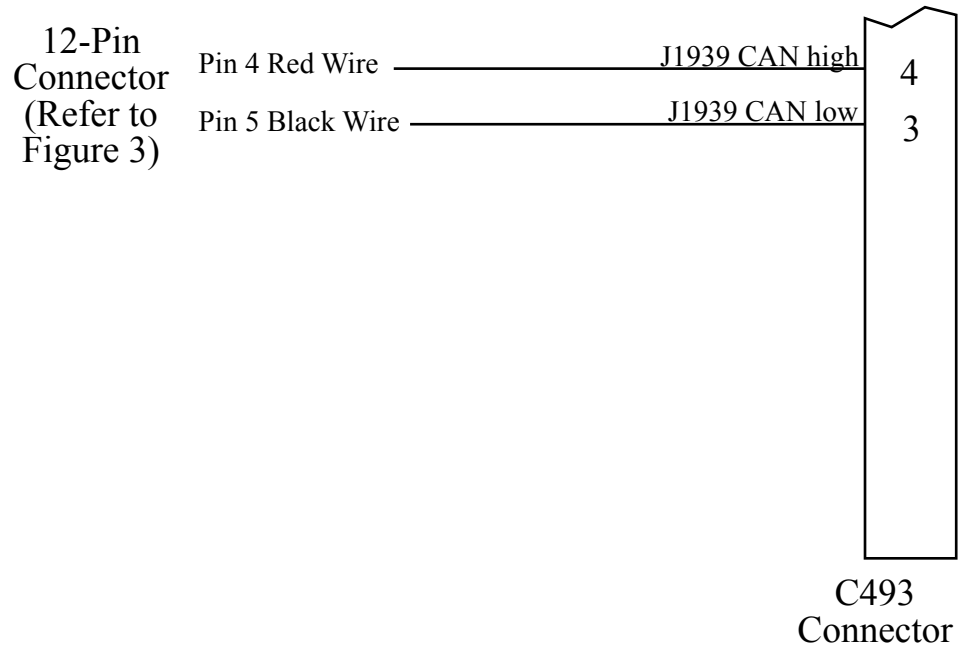

Figure 16. Scania BCI ELA208 Wiring—Type D

Mercedes Harness Connections

DDEC VI
Vehicle Interface Harness
18-PIN Connector #2

Interface Information.

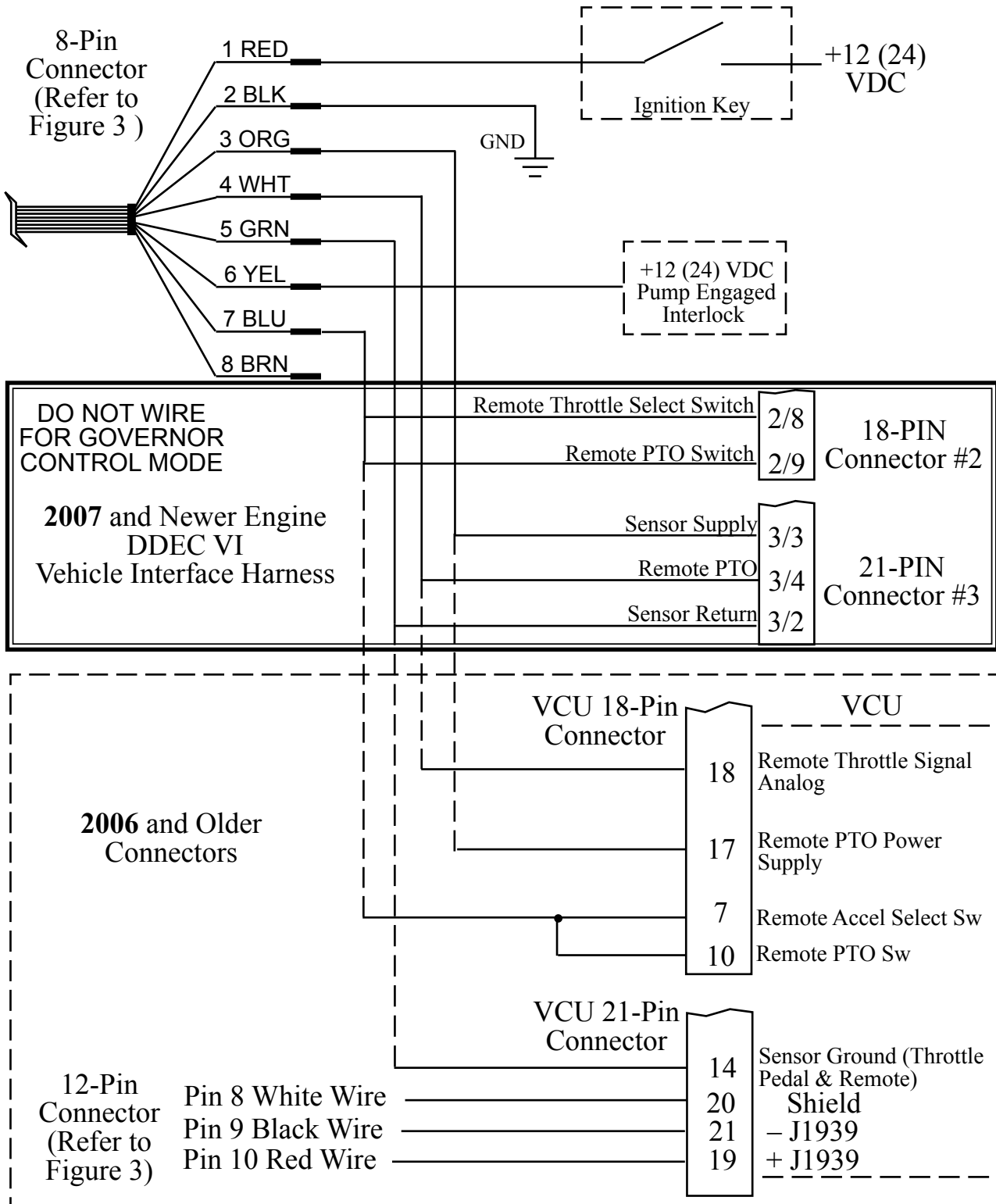
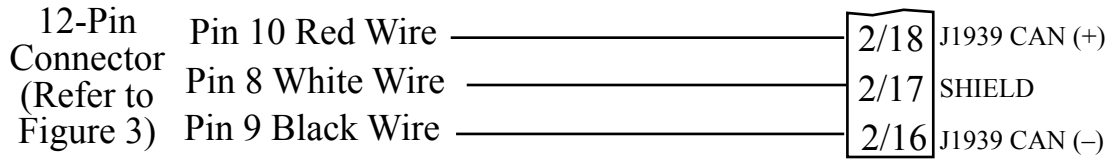

Figure 17. Mercedes ELA210 Wiring

John Deere Harness Connections

Interface Information

CAN Controller will request a torque by means of TSC1. This option is disabled by default and is selectable in the Trim Options page for this application. Source address 57 should be programmed.

Note: Refer to Figure 3 Connector Wiring for Power and Interlock wire connections.

J1939 CAN Bus Control

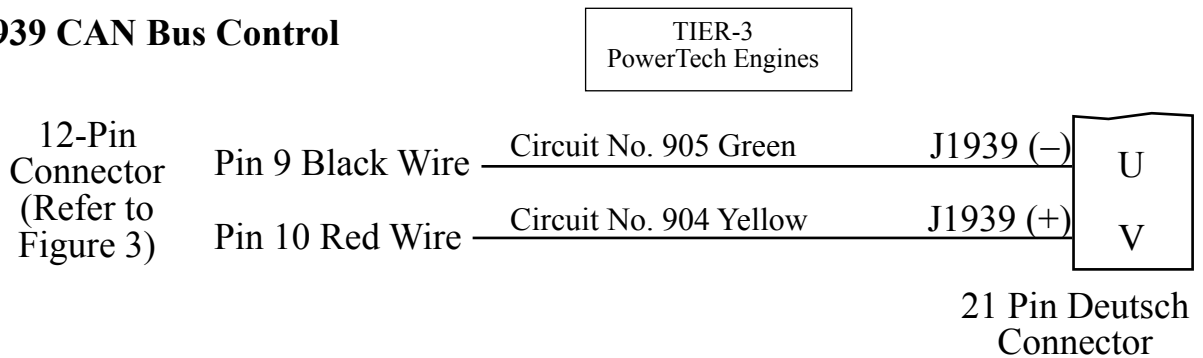

Figure 18. John Deere ELA216 Wiring

MAN Harness Connections

Interface Information

Parameters for various functions can be set on the KSM using MAN-cats II.

The KSM can accept the Engine speed request from the Governor on the A-CAN.

Note: Refer to Figure 3 Connector Wiring for Power and Interlock wire connections.

J1939 CAN Bus Control

18-Pin Connector
X1997

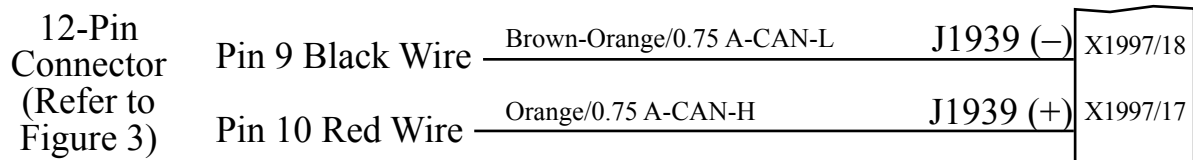

Figure 19. MAN ELA224 Wiring

IVECO Harness Connections

Interface Information

The vehicles shall be ordered with EM w/ CANopen (OPT0384) and FMS (OPT14569). The CANopen XDC needs to be downloaded. This service is available from the official IVECO TeleService tool-chain worldwide. Also an adapter cable needs to be installed to connect Controller to the CAN Bus. This option is currently available only for EURO CARGO-V.

Note: Refer to Figure 3 for the Connector Wiring for Power and Interlock wire connections.

CAN Bus Control

Vehicle Interface Harness
9 Pin 72072C Connector

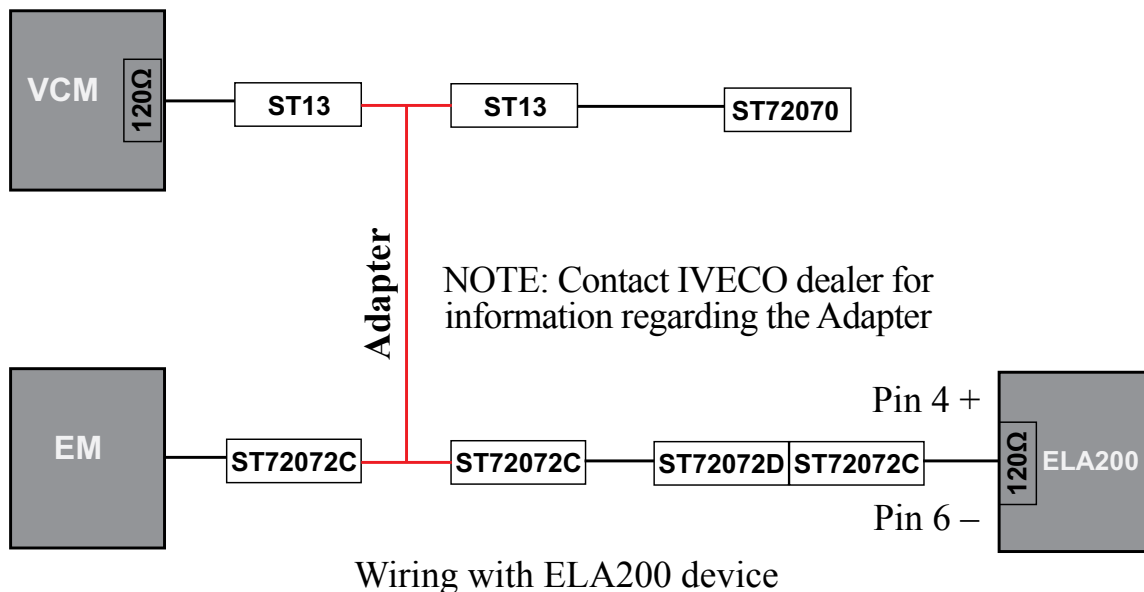
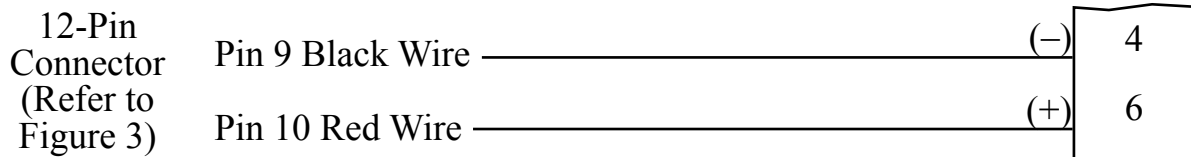

Figure 20. IVECO ELA426 Wiring

FLYBACK DIODE INFORMATION

It is good engineering practice to include a flyback diode when switching an inductive load (solenoid coil, relay coil, electric motor winding, etc.). It is recommended that a flyback diode be installed on inductive devices that share a common power source/ground with a FRC throttle display.

Typical circuit showing a flyback diode installed across an inductive load.

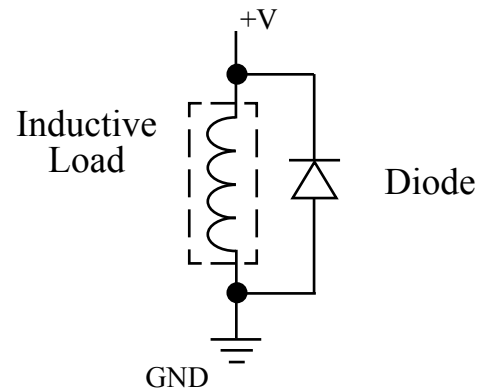

Diagram showing a flyback diode connected on a typical pump primer motor solenoid.

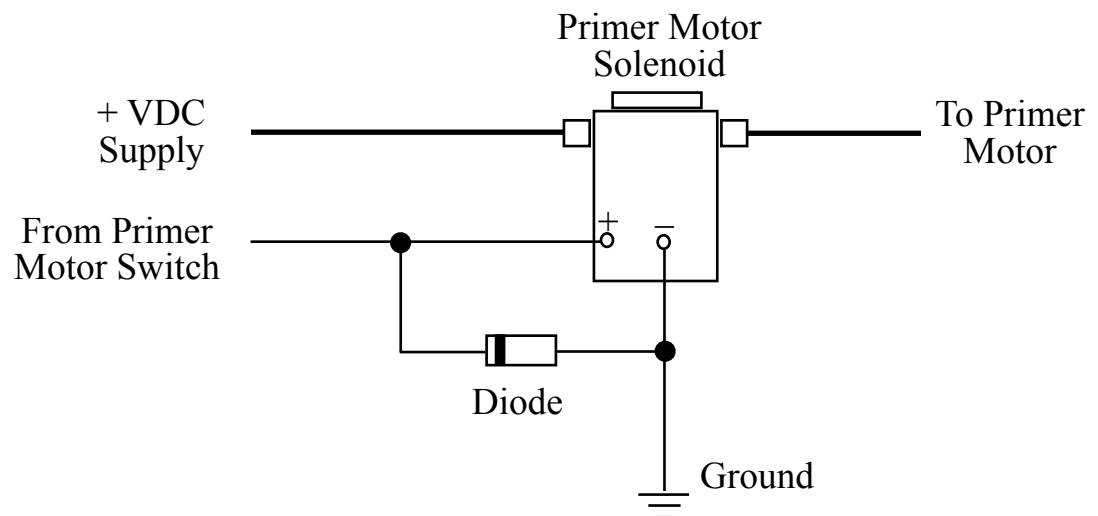

Figure 22. Flyback Diode



DANGER

PERSONAL RESPONSIBILITY CODE

The member companies of FEMSA that provide emergency response equipment and services want responders to know and understand the following:

1. Firefighting and Emergency Response are inherently dangerous activities requiring proper training in their hazards and the use of extreme caution at all times.
2. It is your responsibility to read and understand any user's instructions, including purpose and limitations, provided with any piece of equipment you may be called upon to use.
3. It is your responsibility to know that you have been properly trained in Firefighting and/or Emergency Response and in the use, precautions, and care of any equipment you may be called upon to use.
4. It is your responsibility to be in proper physical condition and to maintain the personal skill level required to operate any equipment you may be called upon to use.
5. It is your responsibility to know that your equipment is in operable condition and has been maintained in accordance with the manufacturer's instructions.
6. Failure to follow these guidelines may result in death, burns or other severe injury.



Fire and Emergency Manufacturers and Services Association, Inc.
P.O. Box 147, Lynnfield, MA 01940 www.FEMSA.org

Copyright 2006 FEMSA. All Rights Reserved