

ECO.100S+/TD

Magnetic drilling machine

EUROBOOR

FOR PROFESSIONALS BY PROFESSIONALS

Technical data

	Metric	Imperial
Annular cutting	Ø 12 - 120 mm	Ø 1/2" - 4 3/4"
Twist drilling	Ø 1 - 31,75 mm	Ø 1/16" - 1 1/4"
Countersinking	Ø 10 - 105 mm	Ø 3/8" - 4 1/8"
Tapping	M3 - M30	Ø 1/8" - 1 3/16"
Length	365 mm	14 3/8"
Width	310 mm	12 3/16"
Height	515 - 715 mm	20 1/4" - 28 1/8"
Stroke	260 mm	10 1/4"
Weight*	31 kg	68.3 lbs
Magnet (l x w x h)	220 x 110 x 64 mm	8 11/16" x 4 5/16" x 2 1/2"
Magnetic force	3,000 kg	6,615 lbs
Motor power	1,900 W	17.3 A
Total power	2,050 W	18.6 A
Speed (no load)		(I) 42 - 110 rpm (II) 65 - 190 rpm (III) 140 - 400 rpm (IV) 220 - 620 rpm
Speed (load 1,900 W, 17.3 A)		(I) 85 rpm (II) 152 rpm (III) 270 rpm (IV) 480 rpm
Spindle (Weldon)	MT3 19.05 mm	MT3 3/4"
Voltage	110 - 120 V / 60 Hz 220 - 240 V / 50 - 60 Hz	

* Without power cord and handles

Features

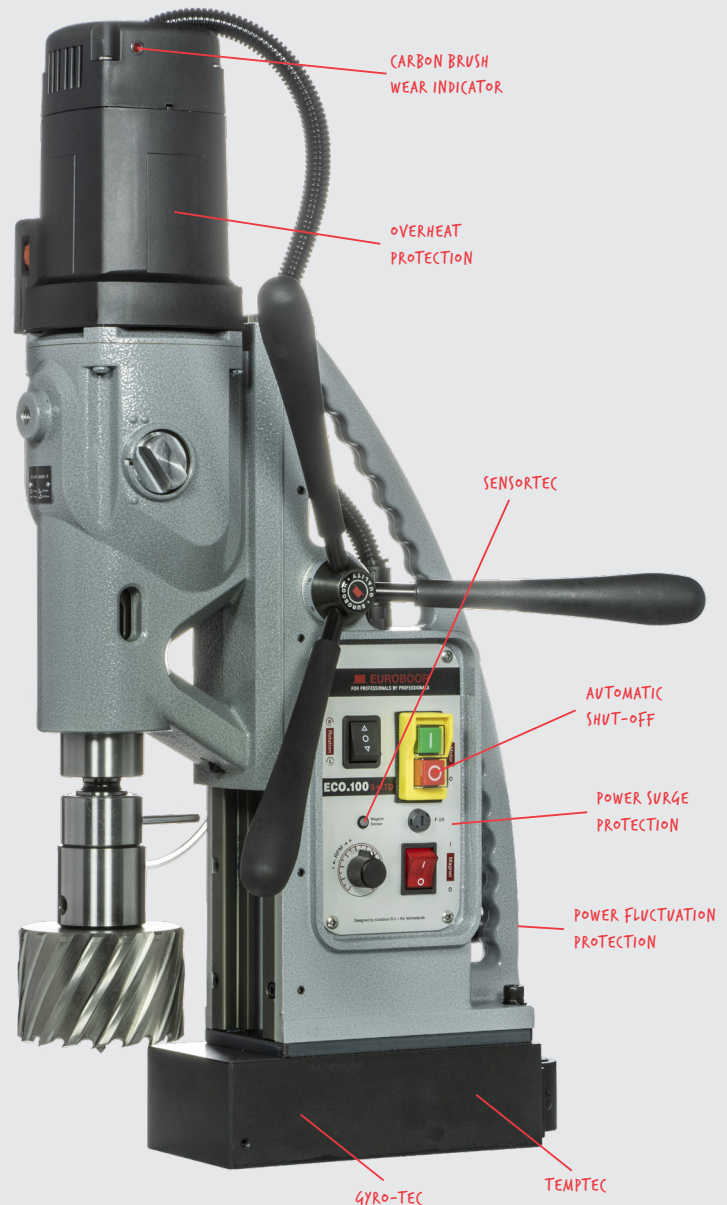
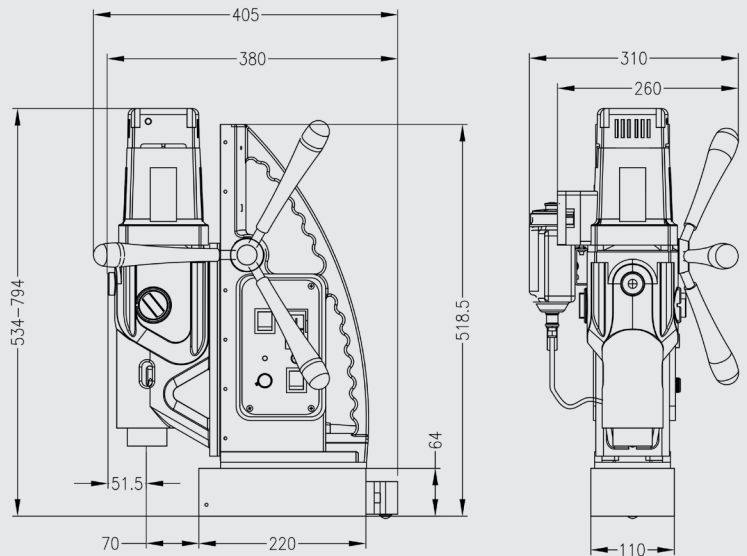
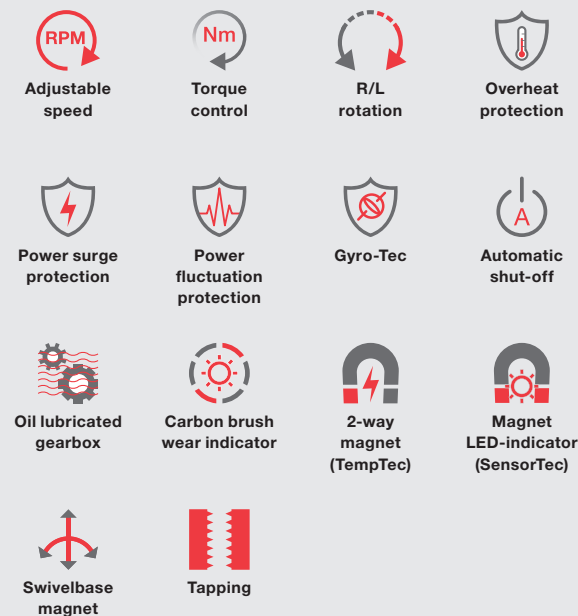

Euroboor makes every effort to meet quality and integrity requirements. That is why we as an organization are proud of the recognition of some leading organizations worldwide:



www.euroboor.com