

**PIUSI**  
®

*Fluid Handling  
Innovation*

**SUZZARABLU**  
**SIDE**  
**PRO/BASIC**

**SUZZARA**  
**BLUE**

DEF3-TM series and DEF6-TM series  
Installation, Use and Maintenance Manual  
(aka M0195 B)

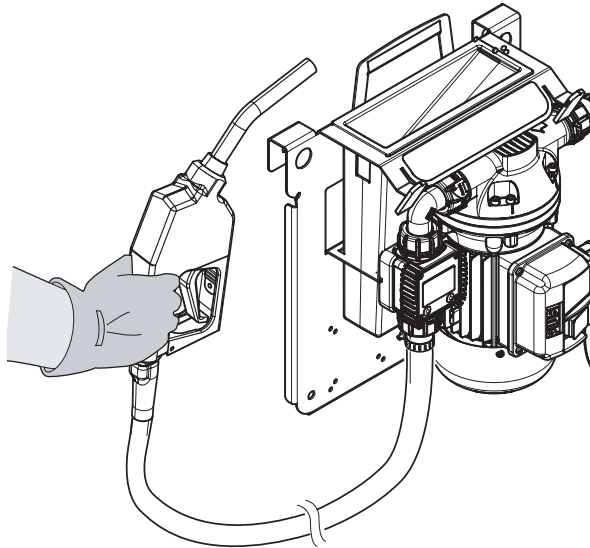

**MADE  
IN  
ITALY**

Installation, use and maintenance

**EN**

**BULLETIN M0195B USA\_00**



*Installation, use and maintenance*

# ENGLISH

## **BULLETIN MO195B**

## 1 INDEX

1	INDEX	3
2	GENERAL WARNINGS	4
3	SAFETY INSTRUCTIONS	4
	3.1 SAFETY WARNINGS	6
	3.2 GENERAL SAFETY RULES	6
	3.3 FIRST AID RULES	7
4	DISPENSING SYSTEM PACKAGING	7
	4.1 PACKAGE CONTENTS/PRE-INSPECTION	7
	4.2 SIDE CONSISTS OF	8
5	MACHINE AND MANUFACTURER IDENTIFICATION	8
	5.1 PLATES POSITION	9
6	TECHNICAL SPECIFICATIONS	10
7	INTENDED USE	10
8	TREATED PRODUCT CHARACTERISTICS	11
9	INSTALLATION	11
10	ASSEMBLY	12
11	INSTALLATION ONTO IBC TANKS	13
12	OPERATION AND USE	14
13	LEAVING THE SYSTEM UNUSED FOR LONG PERIODS OF TIME	16
14	WASHING THE DISPENSING SYSTEM	16
15	MAINTENANCE	16
16	TROUBLESHOOTING	17
17	DEMOLITION AND DISPOSAL	18

## 2 GENERAL WARNINGS

### Warnings

To ensure operator safety and to protect the dispensing system from potential damage, workers must be fully acquainted with this instruction manual before attempting to operate the dispensing system.

### Symbols used in the manual



The following symbols will be used throughout the manual to highlight safety information and precautions of particular importance:



#### ATTENTION

*This symbol indicates safe working practices for operators and/or potentially exposed persons.*



#### WARNING

*This symbol indicates that there is risk of damage to the equipment and/or its components.*

#### NOTE

*This symbol indicates useful information.*

### Manual preservation Reproduction rights

This manual should be complete and legible throughout. It should remain available to end users and specialist installation and maintenance technicians for consultation at any time.

All reproduction rights are reserved by Piusi S.p.A. The text cannot be reprinted without the written permission of Piusi S.p.A.

© Piusi S.p.A.

THIS MANUAL IS THE PROPERTY OF Piusi S.p.A.

**ANY REPRODUCTION, EVEN PARTIAL, IS FORBIDDEN.**

This manual belongs to Piusi S.p.A., which is the sole proprietor of all rights indicated by applicable laws, including, by way of example, laws on copyrights. All the rights deriving from such laws are reserved to Piusi S.p.A.: the reproduction, including partial, of this manual, its publication, change, transcription and notification to the public, transmission, including using remote communication media, placing at disposal of the public, distribution, marketing in any form, translation and/or processing, loan and any other activity reserved by the law to Piusi S.p.A..

## 3 SAFETY INSTRUCTIONS

### ATTENTION Mains - preliminary checks before inst Maintenance control



*You must avoid any contact between the electrical power supply and the fluid that needs to be FILTERED.*

### FIRE AND EXPLOSION



When flammable fluids are present in the work area, such as gasoline and windshield wiper fluid, be aware that flammable fumes can ignite or explode. To help prevent fire and explosion:



**Before any checks or maintenance work are carried out, disconnect the power source.**

Use equipment only in well ventilated area.

Keep work area free of debris, including rags and spilled or open containers of solvent and gasoline.

Do not plug or unplug power cords or turn lights on or off when flammable fumes are present.

Ground all equipment in the work area.

Stop operation immediately if static sparking occurs or if you feel a shock. Do not use equipment until you identify and correct the problem.

Keep a working fire extinguisher in the work area.

**ELECTRIC SHOCK**

This equipment must be grounded. Improper grounding, setup or usage of the system can cause electric shock.

**Electrocution or death**

Turn off and disconnect power cord before servicing equipment.

Connect only to a grounded electrical outlets.

Use only 3 wire extension cords in accordance with local electrical codes. Extension cords should have a ground lead.

Ensure ground prongs are intact on power and extension cords.

Do not expose to rain. Store indoors.

Never touch the electric plug of socket with wet hands.

Do not turn the dispensing system on if the power connection cord or other important parts of the apparatus are damaged, such as the inlet outlet plumbing, dispensing nozzle or safety devices. Replace damaged components before operation.

Before each use check that the power connection cord and power plug are not damaged. If damaged, have power connection cord replaced before use by a qualified electrician.

The electrical connection between the plug and socket must be kept well away from water.

Unsuitable extension leads can be hazardous, in accordance with current regulations. Only extension cords that are labelled for outdoor use and have a sufficient conduction path should be used outdoors.

For safety reasons, we recommend that, in principle, the equipment be used only with a earth-leakage circuit breaker (max 30 mA).

Electrical connections must use ground fault circuit interrupter (GFCI).

Installation operations are carried out with the box open and accessible electrical contacts. All these operations have to be done with the unit isolated from the power supply to prevent electrical shock!

**EQUIPMENT MISUSE**

**Misuse can cause death or serious injury**

Do not operate the unit when fatigued or under the influence of drugs or alcohol.

Do not leave the work area while equipment is energized or under pressure.

Turn off all equipment when equipment is not in use.

Do not alter or modify equipment. Alterations or modifications may void agency approvals and create safety hazards.

Route hoses and cables away from traffic areas, sharp edges, moving parts, and hot surfaces.

Do not kink or over bend hoses or use hoses to pull equipment.

Keep children and animals away from work area.

Comply with all applicable safety regulations.

**Burn Hazard**

**Equipment surfaces and fluid that is heated can become very hot during operation**

To avoid severe burns do not touch hot fluid or equipment.

**Toxic Fluid or Fumes Hazard**

Read MSDSs to know the specific hazards of the fluids you are using.

Store hazardous fluid in approved containers, and dispose of it according to applicable guidelines.

Prolonged contact with the treated product may cause skin irritation: always wear protective gloves during dispensing.

### 3.1 SAFETY WARNINGS

**ATTENTION**  
Mains - preliminary checks before installation



**Before installation, make sure that the electric power supply network is fitted with a suitable earth-line and complies with the regulations in force. You must avoid any contact between the electrical power supply and the fluid that needs to be pumped.**

**Maintenance control**

Before any checks or maintenance work are carried out, switch the system's power off by disconnecting the plug from the socket.

**ATTENTION**  
Prohibitions



**It is strictly forbidden to support or transport the system using a power supply cable. It is strictly forbidden to support or transport the system using a suction or outlet pipe.**

**ATTENTION**



**In the event of a suspected contamination of the liquid in the car tank, sanitize the tank. Do not use the Urea Car Dispenser before recovery**

### 3.2 GENERAL SAFETY RULES

**Essential protective equipment characteristics**

Wear protective equipment that is: suited to the operations that need to be performed; resistant to cleaning products.

**Personal protective equipment that must be worn**



Wear the following personal protective equipment during handling and installation:  
Safety shoes;



Close-fitting clothing;



Protective gloves;



Safety goggles;

**Other equipment**



Instruction manual

**Protective gloves**



Prolonged contact with the treated product may cause skin irritation; always wear protective gloves during dispensing.

**WARNING**



**Never touch the electric plug or socket with wet hands.**

**Do not switch the dispensing system on if the network connection cable or important parts of the apparatus are damaged, such as the inlet/outlet pipe, nozzle or safety devices. Replace the damaged pipe immediately.**

**Before each use, check that the network connection cable and power plug are not damaged. Have the network connection cable replaced immediately by a qualified electrician.**

**ATTENTION**



**The electrical connection between the plug and socket must be kept well away from water.**

**Unsuitable extension leads can be dangerous. In accordance with current regulations, only extension cords that are labelled for outdoor use and have a sufficient conduction path should be used outdoors.**

**For safety reasons, we recommend that, in principle, the equipment be used only with a earth-leakage circuit breaker (max 30 mA).**

### 3.3 FIRST AID RULES

**Persons who have suffered electric shock**

Disconnect the power source, or use a dry insulator to protect yourself while you move the injured person away from any electrical conductor. Avoid touching the injured person with your bare hands until he is far away from any conductor. Immediately call for help from qualified and trained personnel. Do not operate switches with wet hands.

**NOTE**



**Please refer to the safety data sheet for the product**

## 4 DISPENSING SYSTEM PACKAGING

The dispensing system comes packed in a cardboard box bearing the following markings:

- an arrow indicating the TOP side;
- a label containing all the information relating to the equipment (model, weight, etc.)..

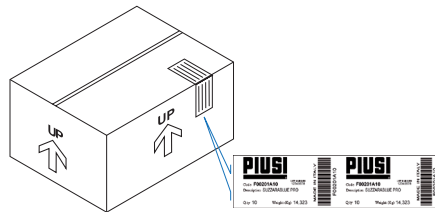

### 4.1 PACKAGE CONTENTS/PRE-INSPECTION

**Foreword**

To open the cardboard packaging, use a pair of scissors or a cutter, being careful not to damage the dispensing system or its components. Open the packaging and check that the following components provided as part of the equipment are available:

**NOTE**



**In the event that one or more of the components described below are missing from inside the package, please contact Piusi S.p.A. technical support.**

**ATTENTION**



**Check that the data on the plate correspond to the desired specifications. In the event of any anomaly, contact the supplier immediately, indicating the nature of the defects. Do not use equipment which you suspect might not be safe.**

## 4.2 SIDE CONSISTS OF

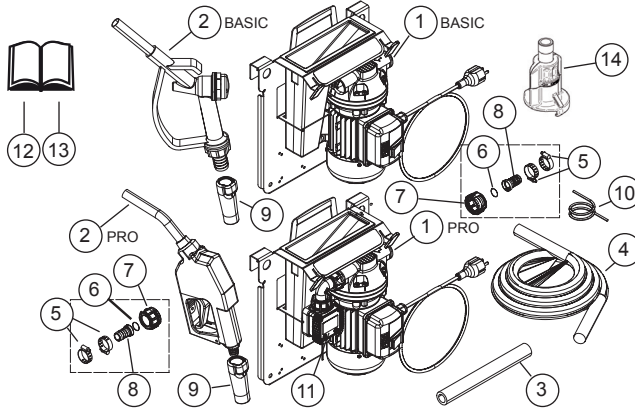

1	PUMP ASSEMBLY	8	NO. 2 HOSE-END FITTINGS
2	NOZZLE	9	SWIVEL PROTECTION
3	SUCTION HOSE	10	SYNTHETIC ROPE
4	DELIVERY HOSE	11	METER K24 (PRO VERSION)
5	NO. 4 CLAMPS	12	USE AND MAINTENANCE HANDBOOK FOR SUZZARAB-LUE DOSING SYSTEM
6	NO. OR SEALS	13	USE AND MAINTENANCE HANDBOOK FOR METER K24 (PRO VERSION)
7	NO. 2 RING NUTS FOR SWIVEL, PLASTIC	14	SUCTION CONNECTION DEVICE

## 5 MACHINE AND MANUFACTURER IDENTIFICATION

The dispensing system comes with an identification plate; this is attached to the pump and contains the following information:

- type;
- lot number / Production year;
- technical data;
- use and maintenance handbook code

**ATTENTION**



**Before installing, always make sure the type of dispensing system is correct and suitable for the available power supply (Voltage/Frequency)**



## 5.1 PLATES POSITION

The dispensing system is equipped with decals and/or plates to provide operators with the necessary important information. Make sure that these do not deteriorate or become detached over time.

**NOTE**



**Should this situation arise, please contact our support department and arrange to have the damaged or missing plates sent back and replaced where necessary.**

The decals present are as follows:

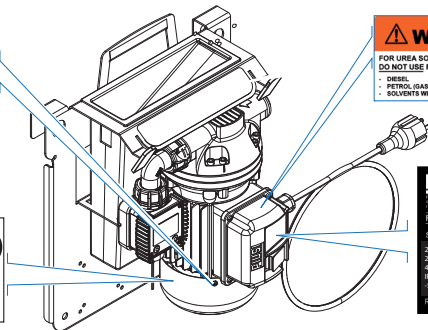

- 1 - protection gloves;  
- safety goggles  
- close-fitting clothing  
- consult the user and maintenance manual;  
- safety shoes



- 3 - CE plate with technical data



- 2 - product for dispensing.



- 4 - label: caution note on the prolonged use of the pump

NE

## 6 TECHNICAL SPECIFICATIONS

<b>Dimensions</b>	
Length (A) *	324 mm / 12,75"
Depth (B)	208 mm / 8,19"
Height (C)	393 mm / 15,47"
<b>Weight</b>	
BASIC Version	13,2 kg / 29,10 lb
PRO Version	15,9 kg / 35 lb
<b>Technical Specifications</b>	
Voltage	230 V
Frequency	50 Hz
Power	520 W
Absorption	2,4 A
Revolutions	2900 rpm
Operating temperature	+23°F / +104°F / -5°C/+40°C
Q-max	10,5 gpm / 40 l/min
P-max	50,75 psi / 3,5 bar
Protection	IP55
Reference manual	MO195

## 7 INTENDED USE

### Intended use

The dispensing system "SUZZARABLU" was designed and built for the distribution of the product called AdBlue®, AUS32 or water.

### Conditions of use

The dispensing system "SUZZARABLU" should be used by observing the following conditions:

Max. temperature of dispensed product: +35 °C.

Min temperature of dispensed product: -11 °C.

Max. temperature of dispensed product permitted by materials: +40°C.

Voltage variation permitted: +/- 5%

Equivalent continuous sound pressure level at the workstation: 75 dB(A)

Make sure that the pump operates within its nominal operating parameters.

**Flammable liquids and explosive atmosphere**



***The system "SUZZARABLU" was not designed for dispensing of diesel, petrol, flammable liquids with flash point <55°C/131°F, or for operation in environments with potentially explosive atmosphere. The use in the above mentioned conditions is forbidden.***

**Unintended use**



***The use of the system for purposes different from those specified in section "Intended use" is strictly forbidden.***

***Do not operate the system for any purpose other than the purpose described within this manual; all other use is considered "IMPROPER" and will result in Piusi S.p.A. disclaiming any responsibility for damage to property, people, animals or to the system itself.***

**ATTENTION**



***Do not keep the pump in motion with the nozzle in the closed position for more than 3 minutes.***

## 8 TREATED PRODUCT CHARACTERISTICS

### Products permitted

The "SUZZARABLU<sup>®</sup>" dispensing system was designed and built to dispense a special liquid, made from an aqueous urea solution, known as AdBlue<sup>®</sup>/ AUS32, based on the ISO 22241 standard SUZZARABLU<sup>®</sup> can also be used with water.

### Products not permitted



#### ATTENTION

**All products not listed in the "Intended Use" and "Treated Product Characteristics" paragraphs are to be considered not permitted, improper and therefore prohibited.**

**Piusi S.p.A. accepts no responsibility for damage to persons or property caused by failure to comply with this requirement.**



## 9 INSTALLATION

### Foreword

The "SUZZARABLU<sup>®</sup>" dispensing system has been designed and equipped for IBC tank installation.

### Authorised installation personnel

Any different form of installation must guarantee secure fastening.

All installations must be carried out by authorised and competent personnel only. Authorised persons must

- install the system in dry and well-ventilated place;
- ensure the correct installation of equipment required for the correct functioning of the pump;
- only use accessories that have been supplied with the system.

### ATTENTION



**The use of accessories that are unsuitable and were not provided with the system is strictly prohibited. Piusi S.p.A. accepts no responsibility for damage to persons, property or the environment caused by failure to comply with this requirement.**

**The "SUZZARABLU<sup>®</sup>" dispensing system is for professional use only.**

**As per the current legislation, the "SUZZARABLU<sup>®</sup>" dispensing system must be installed in premises that are sufficiently well-lit.**

**The "SUZZARABLU<sup>®</sup>" dispensing system has been specifically designed for use in a dry place. If installed outside, an adequate protective covering must be provided.**

## 10 ASSEMBLY

Assemble as shown  
in the illustration.

See components  
number at the cap.

4.2

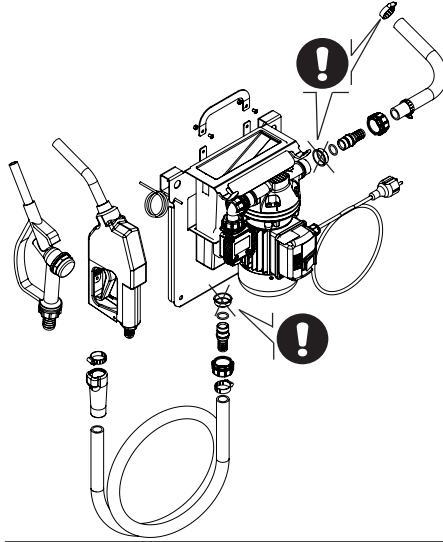

### ATTENTION



**The "SUZZARABLUE" dispensing system is equipped with an IBC tank suction connection device. This must be installed before attempting to operate the system.**

## 11 INSTALLATION ONTO IBC TANKS

### NOTE



*Different forms of installation, i.e. without the tanks indicated, are only permitted if they are capable of guaranteeing that the dispensing system will be firmly and stably fastened.*

Use the hooks and rope provided to firmly and stably fasten the dispensing system to the tank.

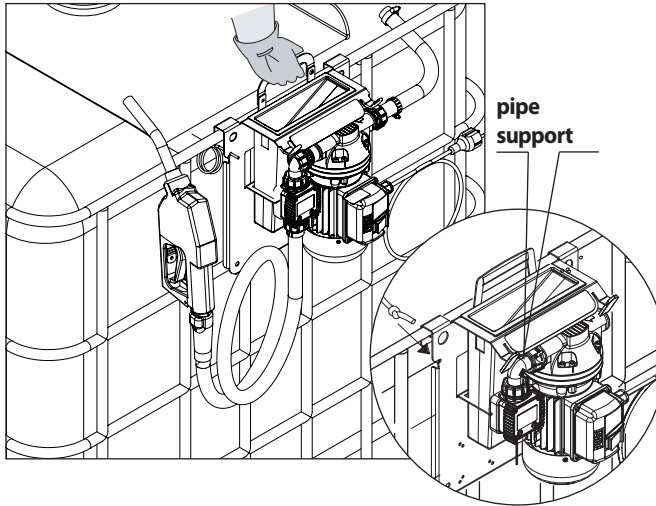

NE

## 12 OPERATION AND USE

**Foreword**

Directions on how to start and stop operation of the system are given below:

**WARNING**



To remove any substance residue or foreign matters from the pipes, wash the system before putting it into operation. To wash the system, follow the same dispensing procedures using demineralized or deionized water and eventually rinse with AUS32 / D.E.F.

**ATTENTION**



During operation the motor may be hot: be careful.

**WARNING**



For the proper functioning of the system, allow a 20-minute stop for every 20 minutes of dispensing.

**ATTENTION**



Operation of the pump without dispensing is only admitted for periods of no longer than 3 minutes.

**WARNING**



We recommend that the pump remains switched off whenever the system is not in use.

**ATTENTION**



If ever the voltage is lagging, push the switch to the OFF position and return the nozzle to its rest position with its lever not activated.

Getting started:



EMPTY  
NOZZLE  
HOLDER

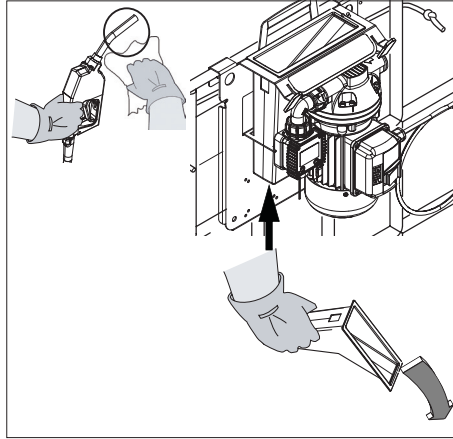

**ATTENTION**



Should any sealants be used on the suction and delivery circuit of the pump, make sure that these products are not released inside the pump.

Foreign bodies in the suction and delivery circuit of the pump could cause malfunctioning and breakage of the pump components.

In case of prolonged dry-running of the pump, the suction circuit may be empty and suction may become difficult. If so, fill the suction circuit with demineralised water

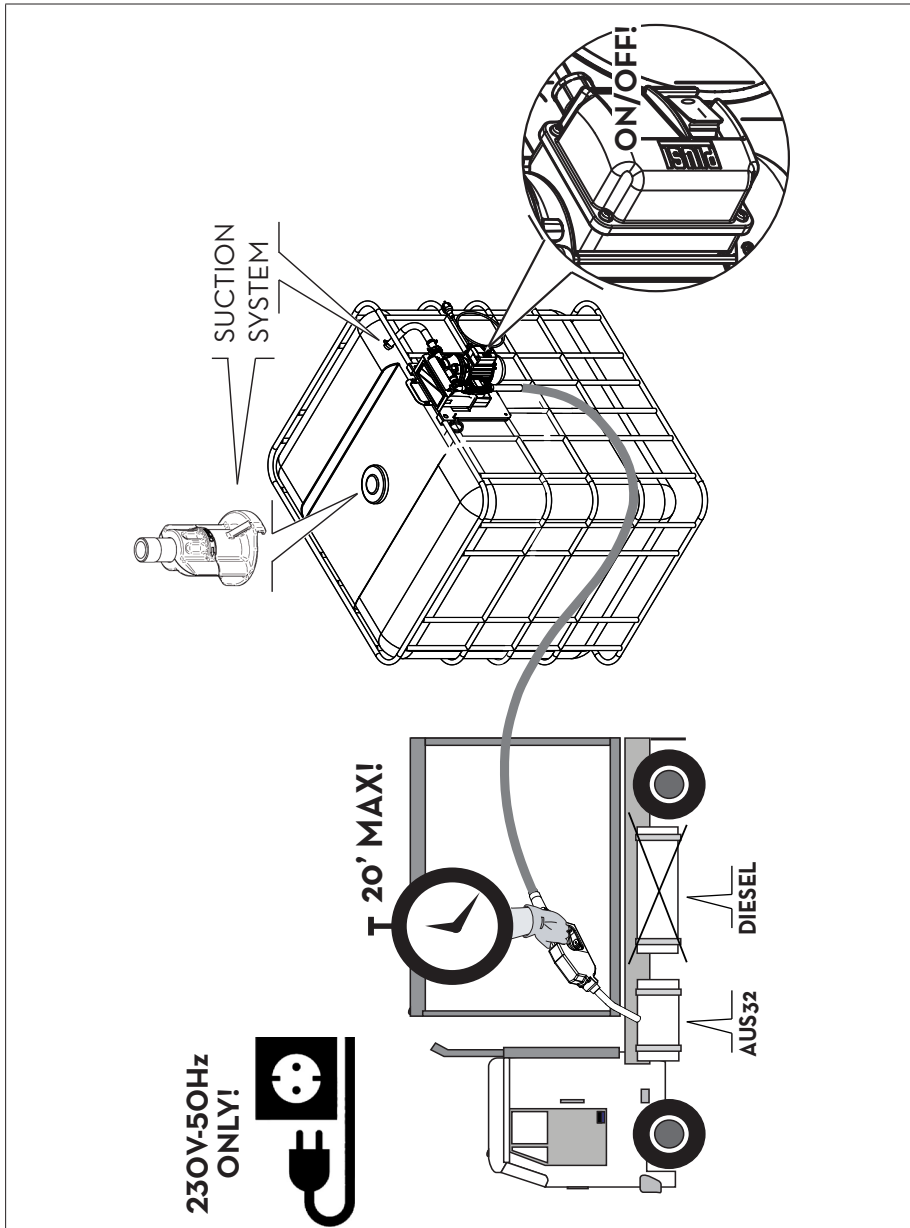

## 13 LEAVING THE SYSTEM UNUSED FOR LONG PERIODS OF TIME

**What to do**

Whenever it is thought that the system will remain unused for at least 15 days, it must be emptied in order to prevent the product from crystallising inside. This shall be followed by a washing cycle..

## 14 WASHING THE DISPENSING SYSTEM

**Foreword**

The dispensing system requires washing in order to remove product crystallisation which may damage the plant.

**ATTENTION**



**Wear personal protective equipment (PPE) when performing the wash cycle.**

**DISPOSAL**

**Use only demineralised water to wash the system.**

Liquids resulting from washing must be disposed of in accordance with the laws prevailing in the country of use.

**ATTENTION**



**By following the same modes of delivery described above, the dispensing system can be washed by sucking up demineralised water from the clean container and collecting the resulting mixture in a different disposable container.**



## 15 MAINTENANCE

**Safety instructions**

The dispensing system was designed and built to require a minimal amount of maintenance. Before carrying out any maintenance work, disconnect the dispensing system from any electrical and hydraulic power source.

During maintenance, the use of personal protective equipment (PPE) is compulsory. In any case always bear in mind the following basic recommendations for a good functioning of the pump

**Authorised maintenance personnel Measures to be taken**

All maintenance must be performed by qualified personnel. **Tampering can lead to performance degradation, danger to persons and/or property and may result in the warranty being voided.**

Whenever there is risk of frost, empty the circuit and the pump, taking care to place the pump in an environment where the temperature is no lower than 0°C/32°F.

Check that the labels and plates found on the dispensing system do not deteriorate or become detached over time.

**ONCE A**

**WEEK:**

- Check that the pipe connections are not loose to prevent any leaks;

- Check and keep the filter installed on the suction line clean.

**ONCE**

- Check the pump body and keep it clean and free of any impurities;

**A MONTH:**

- Check that the electrical supply cables are in good condition.



## 16 TROUBLESHOOTING

<b>PROBLEM</b>	<b>POSSIBLE CAUSE</b>	<b>CORRECTIVE ACTION</b>
<b>THE MOTOR IS NOT TURNING</b>	Lack of electric power	Check the electrical connections and the safety systems.
	Rotor jammed	Check for possible damage or obstruction of the rotating components.
	Motor problems	Contact the Service Department
<b>THE MOTOR TURNS SLOWLY WHEN STARTING</b>	Low voltage in the electric power line	Bring the voltage back within the anticipated limits
<b>LOW OR NO FLOW RATE</b>	Low level in the suction tank	Refill the tank
	Foot valve blocked	Clean and/or replace the valve
	Filter clogged	Clean the filter
	Excessive suction pressure	Lower the pump with respect to the level of the tank or increase the cross-section of the tubing
	High loss of head in the delivery circuit (working with the by-pass open)	Use shorter tubing or of greater diameter
	By-pass valve blocked	Contact the Service Department
	Air entering the pump or the suction tubing	Check the seals of the connections
	A narrowing in the suction tubing	Use tubing suitable for working under suction pressure
	Low rotation speed	Check the voltage at the pump. Adjust the voltage and/or use cables of greater cross-section
	The suction tubing is resting on the bottom of the tank	Modify tubing properly.
	Freezing of the pump or motor.	Thaw the pump and check for damage. Starting a frozen pump can cause damage to the motor and to the pump itself
	Leaks in the pump outlet pipe.	Check the seal at the pipe's connections and inspect the pipe for possible damage.
	Failure to prime	fill the suction hose with demineralised water
	<b>INCREASED PUMP NOISE</b>	Cavitation occurring
Irregular functioning of the by-pass		Dispense until the air is purged from the by-pass system.
Presence of air in the liquid to be pumped.		Verify the suction connections
<b>LEAKAGE FROM THE PUMP BODY</b>	Pump damage	Contact the Service Department

 ZE

## 17 DEMOLITION AND DISPOSAL

### Foreword

If the system needs to be disposed, the parts which make it up must be delivered to companies that specialize in the recycling and disposal of industrial waste and, in particular:

### Disposing of packing materials

The packaging consists of biodegradable cardboard which can be delivered to companies for normal recycling of cellulose.

### Metal Parts Disposal

Metal parts, whether paint-finished or in stainless steel, can be consigned to scrap metal collectors.

### Disposal of electric and electronic components

These must be disposed of by companies that specialize in the disposal of electronic components, in accordance with the indications of directive 2012/19/EU (see text of directive below).



Information regarding the environment for clients residing within the European

### Union

European Directive 2012/19/EU requires that all equipment marked with this symbol on the product and/or packaging not be disposed of together with non-differentiated urban waste. The symbol indicates that this product must not be disposed of together with normal household waste. It is the responsibility of the owner to dispose of these products as well as other electric or electronic equipment by means of the specific refuse collection structures indicated by the government or the local governing authorities.

Disposing of RAEE equipment as household wastes is strictly forbidden. Such wastes must be disposed of separately.

Any hazardous substances in the electrical and electronic appliances and/or the misuse of such appliances can have potentially serious consequences for the environment and human health.

In case of the unlawful disposal of said wastes, fines will be applicable as defined by the laws in force.

### Miscellaneous parts disposal

Other components, such as pipes, rubber gaskets, plastic parts and wires, must be disposed of by companies specialising in the disposal of industrial waste.

This page left intentionally blank

© PIUSI S.p.A.

**EN.** This document has been drawn up with the greatest attention to precision and accuracy of all data herein contained. Nevertheless, PIUSI S.p.A. denies liability for any possible mistake or omission.



*Fluid Handling  
Innovation*

**piusi.com**  
PIUSI SpA • Suzzara MN Italy

---

**BULLETIN MO195 B USA\_00 EN**