

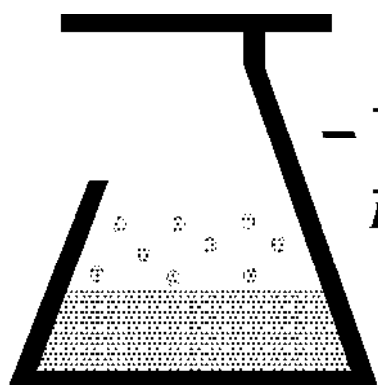

**Precision Instruments for Research and Industry**

**J-KEM Scientific  
Reaction Controller**



**- KEM Scientific, Inc.**  
*Instruments for Science from Scientists*

# Index

Program	Description	Page
<b>Hardware and Software Installation</b>	Hardware and software installation	3
<b>KEM-Rx Software Operating Modes</b>	Explains the four operating mode of the software and various hardware configuration.	5
<b>Reaction Controller Program</b>	Control program for the addition of multiple reagents, regulation of stirring, temperature, and pH. Entering and Running Programs Editing Programs Graphing Data Logging Vacuum controller pressure connections.	7 11 16 18 20 22 24
<b>KEM-Rx Instrument Control</b>	Simple automation of external instruments, like chillers and stirrers.	26
<b>pH Stat Program</b>	Titrate a solution, then maintains a user entered pH	29
<b>The Timed Addition Program</b>	Adds a user specified volume of a single reagent at any specified rate.	32
<b>The Multi-Reagent Delivery Program</b>	Allows the user to construct up to a 16-step program to sequentially add multiple reagents to a single reactor, or multiple reagents sequentially to multiple reactors.	34
<b>Concurrent Addition Program</b>	For Dual syringe pumps only. Simultaneously runs two independent addition programs in two independent reactors.	36
<b>Parallel Addition Program</b>	Simultaneously adds a single reagent to multiple, parallel reactors.	39
<b>Program Builder</b>	Allows the user to construct a multi-step syringe pump program by manually arranging a sequential series of commands in a drag-and-drop environment. Also allows control of the syringe pump from a remote computer.	54
<b>Manual Control</b>	Manual operation of every option and feature of the syringe pump.	57
<b>User Suggested Programs</b>	Suggested programs from users that others may find helpful.	59
<b>Temperature Control Functionality</b>	 Adding a digital temperature controller to any program.	60
<b>Installing a Syringe or Distribution Valve</b>	Instructions for how to replace a syringe and distribution valve.	62
<b>Pump Configuration Form</b>	How to configure the pump for different size syringes and valves.	63
<b>Infinity Controller Configuration</b>	Defines the configuration of analog sensors and connected instruments on the Infinity Controller	

## Hardware Installation

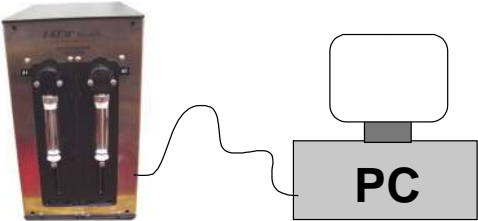
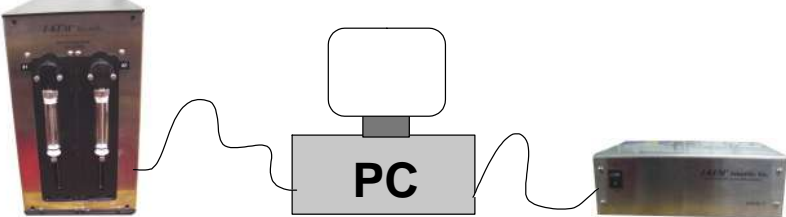
	<p>It's important to understand that this system consists of two independent instruments that can be used separately, or in combination with each other.</p>	
	<p>When just the syringe pump is connected to the PC, the experiments defined for just the syringe pump software can be used.</p>	
	<p>When the syringe pump and the Infinity controller are both connected, the standard syringe pump programs are available, plus two additional programs appear that use the analog sensors attached to</p>	
<p>the Infinity controller. Note, in order for the syringe pump and the Infinity controller to be detected, they <b>MUST</b> be powered up prior to starting the reaction controller software.</p>		
<p>The standard Infinity controller has analog inputs for two type T thermocouples, 1 pH probe, and one pressure input. Additionally, one of the serial ports on the side of the controller is programmed to operate an overhead stirrer, a second port is configured for a chiller, and a third port is available for an additional instrument.</p> <p><b>Analog inputs</b> – If you wish to use the thermocouple and pH probe inputs, then attach the sensors to the appropriate connectors. To monitor the pressure of an attached reactor, connect a piece of tubing from the pressure transducer input on the back of the controller to the reactor to monitor.</p> <p><b>Serial Inputs</b> – Connect a 9-pin serial cable between the port on the side of the controller labeled "Stirrer" to the serial port on the stirrer. Connect a second serial cable between the port on the side of the controller labeled "Chiller" to the serial port of the chiller. <b>NOTE</b> – prior to ordering, the model number of the chiller and stirrer must be specified.</p>		

## Software Installation

1. **Install the syringe pump drivers.** On the enclosed flask disk, open the folder titled Syringe Pump Drivers and double click on the file:  SyringePump DriverInstaller\_v130.exe .
2. **Install the Infinity software.** On the enclosed flask disk, double click on the file titled Setup.exe to install the Infinity software.
3. **Install the Infinity Controller Drivers.** Connect the Infinity controller to a USB port on the PC, then turn power on to the controller. Under Windows 7 (Windows XP will be similar), the controller will be recognized, but the drivers will not install automatically, rather, they must be installed manually from the Device Manger in the Control Panel. If you do not know how to install drivers manually, please contact your IT department for assistance. Note, there are two drivers that must be installed manually. With Windows 8, you must go through the procedure to install "Unsigned Drivers". The needed drivers are on the flash disk in the folder titled Infinity Drivers.
4. **Start the system for the first time.** Connect the Infinity controller and the syringe pump to USB ports on the PC. Turn on power to both units. Double click on the KEM-Rx icon that was placed on the desktop during software installation.

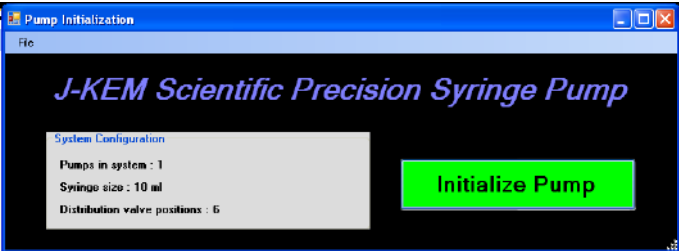
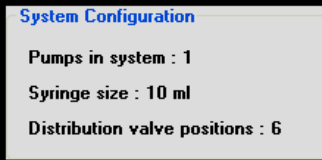
 	<p>The initialization screen appears. The User MUST look at the syringe pump parameters that appear in the gray box and verify that the syringe size and the number of pump ports is correct. If the description is correct, then click the Initialize Pump button to complete the installation process. If the description is not correct, the user must enter the correct information manually. See the section titled Pump Configuration Form.</p>
--	---

# Infinity Reaction Controller

J-KEM Scientific's Reaction controller combines precision hardware to take measurements from analog sensors like pH probes and thermocouples, a precision fluid delivery pump, and versatile software that adapts to different hardware configurations to control and data log only the reaction parameters needed in your research application.

The reaction controller consists of two hardware modules, the Infinity controller analog box and the syringe pump module. The Infinity controller reads the input from analog sensors like a thermocouple and pH probe, and operates instruments like overhead stirrers and circulating chillers. The syringe pump module dispenses fluids according to a user entered program.



Infinity Controller



Syringe Pump

KEM-Rx software can be run in four modes, where each mode offers different features and ease of setup. The four modes of KEM-Rx software depend on which pieces of equipment, (i.e., the Infinity controller and syringe pump) are connected to the PC when KEM-Rx is started.

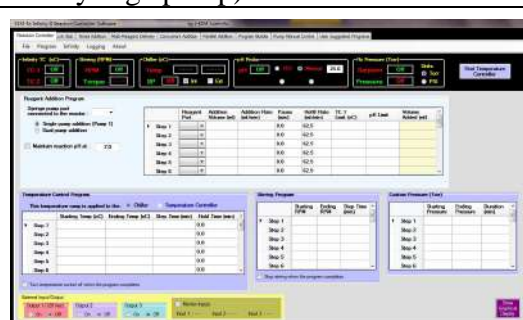

## Mode 1 – The Infinity Controller and Syringe Pump are Both Connected to the PC

When all of the features of the Infinity controller system are needed, both the Infinity controller analog box and the syringe pump should be connected to the PC. The Infinity controller provides readings from analog sensors like thermocouples, pH probes, pressure transducers. The syringe pump is used to deliver reagents or maintains solution pH. Control of instruments like stirrers and chillers is provided by the KEM-Rx software. In this configuration, all of the program tabs (experiment tabs) of KEM-Rx software are active.



## Mode 2 – Only the Infinity Controller is Connected to the PC

With just the Infinity controller connected to the PC when KEM-Rx software is started, all of the analog sensors on the Infinity controller are available for use along with the control of external instruments like stirrers and chillers. This configuration is useful when the object is to monitor and control a reaction, but there is no requirement for reagent or fluid addition using the syringe pump. In this configuration, only the Reaction Controller experiment tab is activated in the KEM-Rx software, the other tabs (that rely on the presence of the syringe pump) are inactive. Also, analog sensor group boxes on the Reaction Controller tab (i.e., thermocouple, pH, pressure) are inactivated.

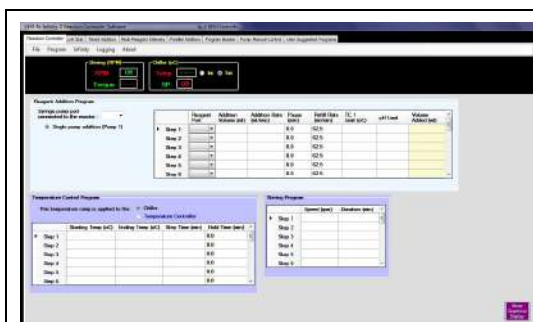

**Mode 3 – Only the Syringe Pump is Connected to the PC**  
 With just the syringe pump connected to the PC when KEM-Rx software is started, the software enables all of the fluid addition experiment tabs. Additionally, on the Reaction Controller tab, the stirrer and chiller controls are activated, since these can still be operated by the KEM-Rx software. This configuration is useful when you only need to use the syringe pump programs that add (multiple) reagents at a function of time.

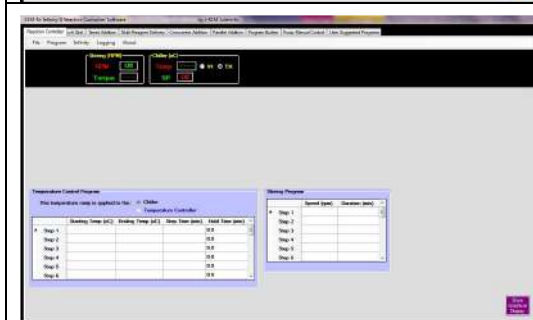

**Mode 4 – KEM-Rx Instrument Control**  
 When neither the Infinity controller or the syringe pump are connected to the PC, KEM-Rx is still capable of operating and data logging external chillers and stirrers. This mode is frequently useful in process plant operations. In this configuration, none of the syringe pump experiment, or any of the analog sensor inputs on the Reaction controller tab are activated. See the section titled KEM-Rx Instrument Control for additional information.

## An Open Community of Research

KEM-Rx automates all of the standard, and many exotic, fluid addition programs used in research chemistry and biology. The KEM-Rx package includes both a standard setup project that installs KEM-Rx on a PC, and optionally, a copy of the original source code (written in VB.net) for researchers who want to extend the application by modifying existing, or authoring new syringe pump programs.

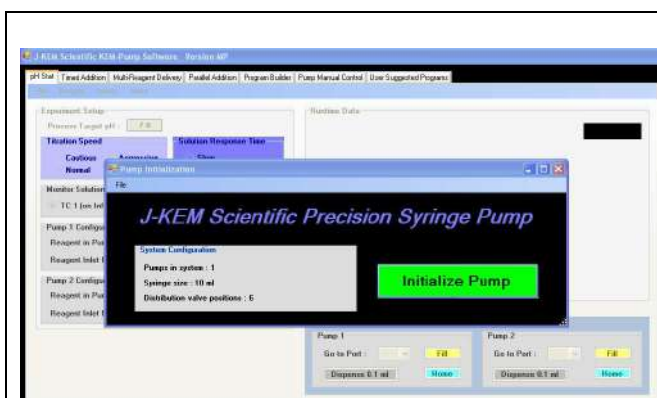

When KEM-Rx is started, the initialization screen shown is presented. Initialize the software and the pump by clicking on the green Initialize Pump button. Once initialized, KEM-Rx activates different programs, depending on the model and configuration of the syringe pump. The names of the available programs appear on the tabs on the top portion of the screen. Each program is described in a separate sections later in this manual. If the syringe pump is not connected when

KEM-Rx is started, then a notice appears stating that the pump was not detected and only the analog sensor and instrument controls tabs that use the Infinity controller are activated.

# Reaction Controller Program

This tab appears on the KEM-Rx software only when the Infinity-II controller is powered on and connected to the PC.

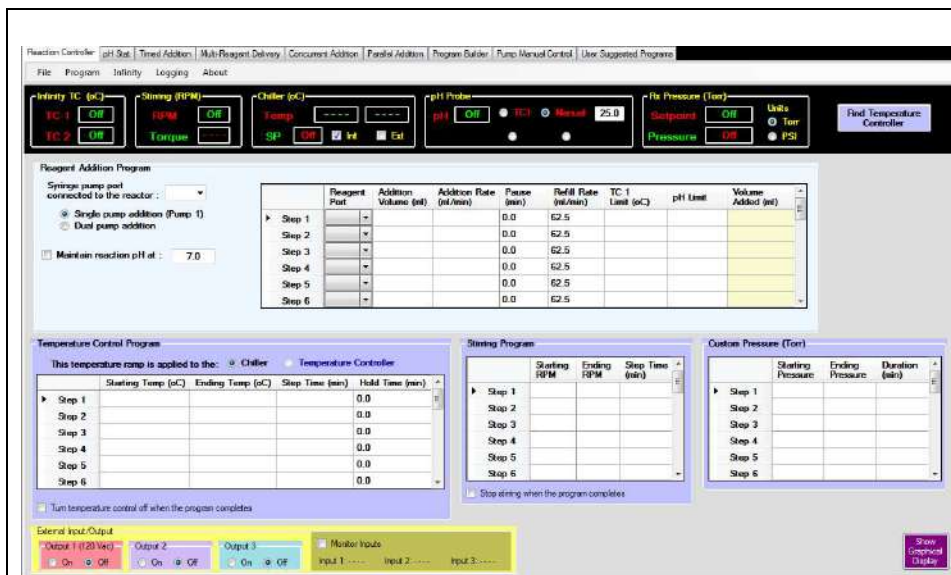

This program allows the user to operate the various analog input sensors (thermocouples, pH probe, pressure), and instruments connected to the Infinity controller.

Additionally, multi-step reagent addition, stirring, and chiller programs can be run in parallel.

## Manual Sensor and Instrument Control



The top bar of the custom tab is the interface to turn On/Off and show the current reading of each of the Infinities sensors and connected instruments. The standard Infinity configuration takes readings from two thermocouples, one pH probe, and one pressure transducer. The standard configuration of the Infinity also operates two instruments, a stirrer and chiller through a RS232 or USB serial connection.

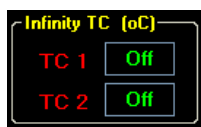

The Infinity controller has input channels for two thermocouples.

To begin taking readings from either thermocouple channel 1 or 2, click in the box associated with the thermocouple currently showing that the sensor is “Off”. The thermocouple is initialized and begins to show the sensed temperature.

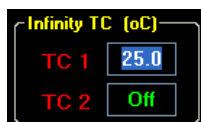

To turn a thermocouple channel off, click in the box showing the sensed temperature and the channel will return to “Off”



The pH probe is enabled by clicking in the pH display box when “Off” is showing. pH readings are a function of temperature and the user must specify the object used to determine the solution temperature. The options are:

**TC1** – This is the Infinity thermocouple input 1. If this option is selected, connect a thermocouple to the TC1 input, then place the probe in the monitored solution near the pH probe.

**Manual** – The user can enter the solution temperature in the text box provided.

**Chiller** – If a chiller is connected to the Infinity and is turned on, then this option is enabled. The temperature of the chiller is used for pH measurements.

**Temp Cont** – If a J-KEM Scientific temperature controller is connected to any USB port on the PC and is turned on, then this option is enabled. The solution temperature measured by the controller is used for pH measurements.

To disable the pH probe, click in the pH reading box and the reading will show “Off”. It is important that the pH input be calibrated periodically, and especially before starting an important experiment.



To calibrate the pH probe, select Calibrate pH Probe from the Infinity menu. Enter the pH values of both the acidic and basic standards and the temperature of the buffers in the text boxes provided

Step 1 Place the pH probe in the acidic buffer and allow it to equilibrate to the buffer. While the probe is in the buffer, the millivolt reading of the probe is displayed, when the reading stabilized to a relatively constant value, click the Accept button to record this reading.

Step 2 Place the probe in the basic buffer. Again the display shows the millivolt reading of the probe and once it stabilizes to a constant value, click the Accept button to record the reading.

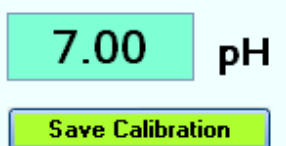

After calibrating on the basic buffer, the display changes to show the calibrated pH reading of the probe. The probe can be placed in both buffers to verify its calibration, when satisfied with the results, click the Save Calibration button.

## Instrument Control Using the Reaction Controller Program

The Reaction Controller tab automates the actions of other manufacture’s instruments, like stirrers, chillers, balances, and pumps by means of serial port commands. The Infinity controller is capable of communicating with many different manufacture’s instruments, but the user must specify the identity of the instrument and the serial channel that it is connected to.

**Note:** Configuration of serial channels is usually performed before the Infinity controller is shipped, but serial channels can also be redefined by the user in the event that additional or new instruments are connected. Instructions on how to connect and configure the software for various manufacturer’s instruments can be found in the section titled *Infinity Controller Configuration*.

### Stirrer Input

If at the time an order was placed, the stirrer is specified, then the Infinity is pre-configured for that stirrer, otherwise it is configured for use with a J-KEM Scientific stirrer. The J-KEM stirrer is connected to the 9-pin serial port on the side of the Infinity controller. Stirrers can optionally be connected to either a USB port on the PC or the Infinity controller, or to the 9-pin serial connector labeled “Stirrer” on the side of the Infinity controller. In the case of IKA stirrers, these must be connected to a USB port, due to their non-standard communication protocol. For the requirements of a specific manufactures stirrer, see the section titled Infinity Controller Configuration.

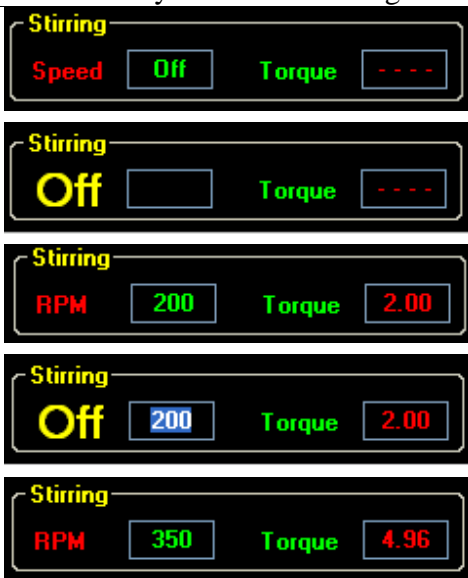

The stirrer is enabled by clicking in the text box next to Speed (i.e., click on the word ‘Off’).

The user can now enter the desired stir rate in the text box, then enter the rate by pressing the Enter key on the PC key pad.

This screen shows the normal display of the stirrer.

To change the stir rate, click in the box next to RPM. This control present two options, the user can type a new speed in the text box, then load the new speed by pressing the Enter key on the PC key pad, or to turn the stirrer off, click on the yellow word “Off”.

### Chiller Input

If at the time an order was placed, the chiller is specified, then the Infinity is pre-configured for that chiller, otherwise it is configured for use with a Polyscience chiller, available from J-KEM Scientific (other chiller options are available). The chiller can optionally be connected to either a USB port on the PC, the Infinity controller, or to the 9-pin serial connector labeled “Chiller” on the side of the Infinity controller. By default, the chiller is specified to be connected to a USB port on the PC or the Infinity controller. For the requirements of a specific manufactures stirrer, see the section titled Infinity Controller Configuration.

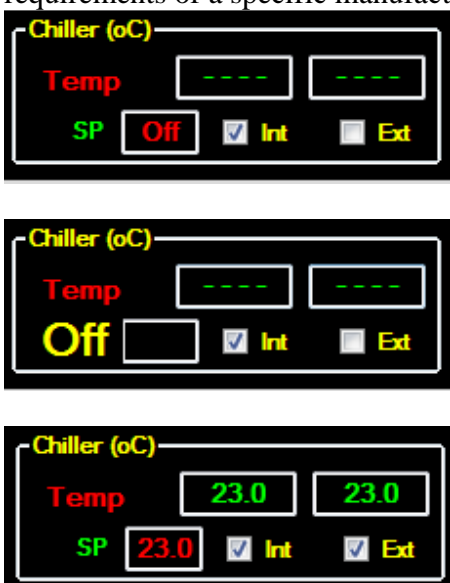

The chiller control operates with the same logic as the stirrer control. To start the chiller, click in the “SP” box and enter the desired temperature.

To turn the chiller off, click in the SP box, then on the yellow word “Off” that appears to the left of the text box.

The chiller can display the internal bath temperature, or if an optional external probe is connected to the chiller, it can display the probe temperature also. Select the temperatures to display by checking the Int or Ext check box.

## Reactor Pressure and Vacuum Regulation

The standard Reaction Controller has a built in vacuum transducer to monitor and data log reactor pressure. Optionally, the vacuum **monitor** can be upgraded to a vacuum **controller**, which allows the user to regulate the vacuum pressure inside of the reactor under program control.

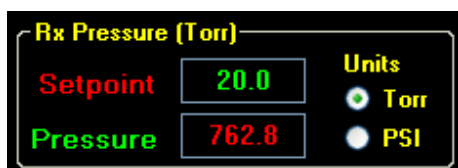
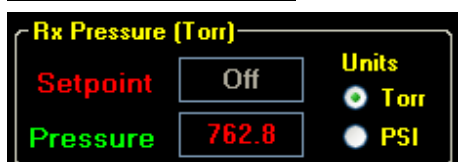
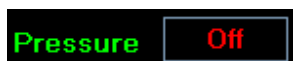

The standard vacuum monitor feature allows the Reaction Controller to display and data log the reactor pressure. The second option allows the Reaction Controller to regulate a vacuum pressure in the reactor. If the pressure control option is added, the Rx Setpoint box of control is enabled, otherwise it is disabled.

### Pressure Display & Data Logging

The standard pressure feature of the Reaction Controller can be turned on by clicking on the word “Off” (red text) in the Pressure display box. When this happens the word “Off” is replaced by a continuous display of reactor pressure. Reactor pressure can also be data logged and graphed.

### Pressure Regulation

The pressure control option allows the user to regulate the vacuum pressure inside of the reactor under program control. If the pressure controller option is installed, the Setpoint box of the Rx Pressure control and the table titled ‘Custom Pressure’ is enabled to allow the researcher to enter a 24-step reactor pressure program. Contact J-KEM for information on adding this option.

## Pressure Connections

The vacuum transducer is built into the Infinity controller, and appears as a Swagelok compression fitting on the back panel. Connect this fitting to the reaction system to monitor system pressure.

If the Vacuum control option is installed, then plumbing of the system is slightly more involved. See the section titled Vacuum Regulator Setup later in this manual.

By default system pressure is displayed as absolute pressure. On the absolute pressure scale, full vacuum is displayed as 0.0 torr (or PSI) and 1 ATM is displayed as 760 torr (or 14.69 PSI). If preferred, pressures can be displayed relative to ATM being set to 0.0. For instructions on how to set up the vacuum regulator, see the section titled Vacuum Regulator Setup, later in this section.

On this scale, vacuum pressures are shown as negative values and positive pressures as positive values.

This preference is set on the Infinity Controller configuration form. From the Infinity menu select Infinity Configuration, then from the Infinity configuration screen select Set ATM to Zero from the DVR Configuration menu.

# Ramp Programs

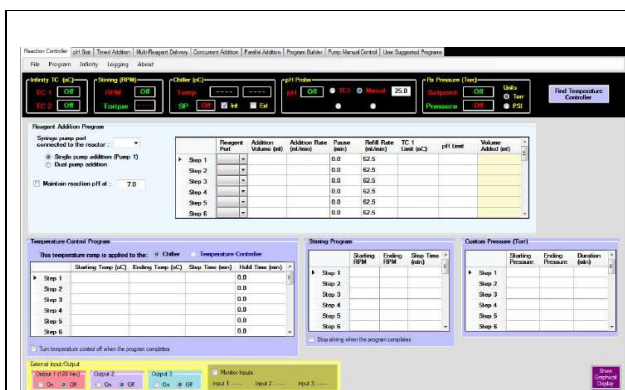

The Reaction Controller form presents controls to simultaneously 1) add reagents using the syringe pump, 2) operate the overhead stirrer, 3) operate a circulating chiller, and 4) control the reactor pressure (vacuum and pressure).

The ramps can be run individually or in parallel. If the user enters and starts a syringe pump program in the table provided, then the other syringe pump program tabs will be deactivated while the pump program is running. The syringe pump program tabs are not deactivated when just a stirring, pressure, and/or chiller

program is running. In this case, while the chiller and stirring programs are running, the user can program and run any of the standard syringe pump programs.

**Reagent Addition Program**

Syringe pump port connected to the reactor:

Single pump addition (Pump 1)  
 Dual pump addition

Maintain reaction pH at:

Select the port the reactor is attached to.  
 Select a single pump or dual pump addition.

	Reagent Port	Addition Volume (ml)	Addition Rate (ml/min)	Pause (min)	Refill Rate (ml/min)	TC 1 Limit (oC)	pH Limit	Volume Added (ml)
Step 1	C	25.0	2.5	10	62.5			
Step 2	B	10.0	1.0	0.0	62.5	50.0	6.5 (A)	
Step 3	D	10.0	2.0	0.0	62.5	50.0	7.5 (B)	
Step 4	F	1.0	0.1	0.0	62.5			
Step 5				0.0	62.5			
Step 6				0.0	62.5			

The reagent program allows the user to enter up to a 24 step addition program. Before entering the program, you need to 1) identify the port that the reactor is attached to and 2) whether you want to use a single pump to add reagents to the reactor, or for systems with a dual position syringe pump, both pumps. Fill in the table with the desired reagent addition information.

Reagent Port – Enter the port on the pumps distribution valve that the reagent is connect to.

Addition Volume (ml) – Enter the volume of reagent to add, in milliliters.

Addition Rate (ml/min) – Enter the reagent addition rate for this step in units of ml/min.

Pause (min) – Following the completion of the reagents addition, the program can pause for a user entered time before proceeding to the next table step.

Refill Rate (ml/min) – This is the rate that the syringe pump fills the syringe at. For viscose solutions, the user may need to enter a lower fill rate than the default rate shown in the table.

TC 1 Limit (oC) – The user can optionally enter an over temperature limit for each step. If the over temperature limit is exceeded, the addition of reagent pauses until the solution temperature falls below the limit. Thermocouple position 1 (TC 1) on the infinity controller is used to sense this temperature limit.

pH Limit - The user can optionally enter a pH limit for each step. If the pH limit is exceeded, the addition of reagent pauses until the pH goes above, or below the entered limit.

This feature pauses the addition of reagent while the pH exceeds a user set limit value.

Pause the addition in this step if :

- The solution is more ACIDIC than the pH limit
- The solution is more BASIC than the pH limit

pH Limit
6.5 (A)
7.5 (B)

In the case of a pH limit, the user must additionally enter whether the limit applies to the solution going above, or below the limit, that is, if addition should be paused if the sensed pH becomes more acidic or less acidic than the limit. When a pH limit is entered, the user is prompted to specify whether the limit should be applied if the solution goes above or below the limit. The table records the pH value entered and then appends a letter to indicate the type of limit. If the pH alarm should trigger if the solution pH becomes more acidic than the value entered, a “(A)” is appended to the value to indicate that it is an Acidic limit. If the pH alarm should trigger if the solution pH becomes more basic than the value entered, a “(B)” is appended to the value to indicate that it is an Basic limit.

The column titled Volume Added is not part of the user input. During a run, the program shows the current steps addition volume in this cell.

	Reagent Port	Addition Volume (ml)	Addition Rate (ml/min)	Pause (min)	Refill Rate (ml/min)	Temp Limit (oC)	pH Limit	Volume Added
▶ Step 1	B	125	150	0:00:24	150.0	50	7	125.0
▶ Step 2	C	10	10	0.0	150.0	50		

The active step of the program is highlighted in green. For instructions on how to edit a running program, see the section titled “Editing an Running Program” later in this manual.

Reagent Addition Program

Step	Reagent Port	Addition Volume (ml)	Addition Rate (ml/min)	Pause (min)	Refill Rate (ml/min)	Temp Limit (oC)	pH Limit
▶ Step 1	B	125	150	5	150.0	50	7
▶ Step 2	C	10	10	0.0	150.0	50	
▶ Step 3				0.0	150.0		
▶ Step 4				0.0	150.0		
▶ Step 5				0.0	150.0		
▶ Step 6				0.0	150.0		

When a temperature or pH limit is exceeded, the current table line turns red and the pump stops adding its content.

	Reagent Port	Addition Volume (ml)	Addition Rate (ml/min)	Pause (min)	Refill Rate (ml/min)	Temp Limit (oC)	pH Limit	Volume Added
▶ Step 1	B	125	150	0:00:24	150.0	50	7	125.0
▶ Step 2	C	10	10	0.0	150.0	50		

When the limit violation clears, the table lines turns green again and the addition resumes.

	Reagent Port	Addition Volume (ml)	Addition Rate (ml/min)	Pause (min)	Refill Rate (ml/min)	Temp Limit (oC)	pH Limit	Volume Added
▶ Step 1	B	125	150	0.5	150.0	50	7	125.0
▶ Step 2	C	10	10	0.0	150.0	50		6.692
▶ Step 3				0.0	150.0			
▶ Step 4				0.0	150.0			
▶ Step 5				0.0	150.0			
▶ Step 6				0.0	150.0			

When an addition step completes that line of the table turns gray and the next step is highlighted green.

Maintain reaction pH at :

Pump 2 is delivering  Acid  Base

Reagent Inlet: A Outlet: B

Maintain reaction pH at :

Pump 2 is delivering  Acid  Base

Reagent Inlet: A Outlet: B

Base Added (ml)

For systems with a dual position syringe pump, there is the option to add a sequence of reagents and to simultaneously maintain the pH of the reaction solution.

Pump position 1 is used to add the reagents defined in the reagent addition table. While the reagent program is running, Pump position 2 can add acid or base to the reaction mixture to maintain a constant solution pH. To enable this feature, place a check in the box titled 'Maintain reaction pH at :' and specify whether pump 2 contains acid or base. Note that the inlet for pump 2 must be port A, and the outlet must be port B. The pH control feature can be started either before the ramp programs are started, or any time after they are started. To start the pH control program, click the green Start Control button.

While the pH control program is running, a window appears that shows the current volume of reagent added. The pH control program can be stopped at any time by clicking the red button titled Stop Control.

To prime the reagent inlet and outlet lines prior to starting the pH control program, select the option Prime Syringe Pump Ports from the Programs menu.

**Stirring Program**

	Starting RPM	Ending RPM	Step Time (min)
▶ Step 1			
Step 2			
Step 3			
Step 4			
Step 5			
Step 6			

Stop stirring when the program completes

### Stirring Program

A stirring program can be up to 24 steps long. Each step consists of a starting speed, and ending speed and a duration for the step. The speed of the stirrer is ramped from the starting to the ending speed during the duration of the step.

At the end of a stirring program, the stirrer continues to mix at speed in the last table entry. If you prefer for the stirrer to turn off at the end of the program, place a check mark in the box titled "Stop stirring when the program completes".

**Temperature Control Program**

This temperature ramp is applied to the:  Chiller  Temperature Controller

	Starting Temp (oC)	Ending Temp (oC)	Step Time (min)	Hold Time (min)
▶ Step 1				0.0
Step 2				0.0
Step 3				0.0
Step 4				0.0
Step 5				0.0
Step 6				0.0

Turn temperature control off when the program completes

### Temperature Program

A temperature control program is used to regulate the temperature of the monitored reaction, and can be up to 24 steps long. Each program step consists of a starting temperature, an ending temperature, and the step time to ramp from the starting to the ending temperature. At the end of each ramp step, the user can enter a

time to pause the program (Hold Time) before proceeding to the next step. There are two options for controlling the reaction temperature, the first is to control the reaction temperature using an attached circulating chiller. This is possible when the reaction is run in a jacketed reactor. The second option is to use an attached J-KEM Scientific temperature controller and a heating jacket.

When the Chiller radio button is selected, then the programmed temperatures in the table are sent to the chiller to implement the ramp entered. In this case, a chiller must be connected to the Infinity and circulator fluid plumbed to the reactor. The circulator can both heat and cool the reaction mixture.

When the Temperature controller (only enabled if a controller is connected and turned on) radio button is selected, then the temperature ramp is sent to the J-KEM temperature controller.

In this case, the temperature controller must be connected to a heating jacket on the reactor. A J-KEM controller can only heat a reaction mixture and has no provision for cooling.

In the case when temperature is regulated by a circulating chiller, the user has the option of basing regulation on the internal bath temperature, (by checking the “Int” check box in the Chiller display panel at the top of the screen), or if an optional external probe is connected, regulation can be based on the external probe temperature (by checking the “Ext” check box in the Chiller display panel at the top of the screen). When both boxes are checked, control defaults to the external probe.

When a temperature ramp step completes, the program doesn’t advance to the next step until the reaction temperature (i.e., sensed temperature) is within 0.5C of that steps ending temperature. For example, if a steps requires that the chiller, or temperature controller, ramp from 10 to 30C, but at the end of the ramp step, the actual reaction temperature is 24C, the program pauses until that actual sensed temperature is heats to 29.5C. Once the sensed temperature is within 0.5C of the current steps ending temperature, the program advances to the next step. During this period when the program is paused waiting for the sensed temperature to reach the requested ending temperature, the ramp table displays “Wait for SP” in the timer display window.

At the end of a temperature control program, the circulating chiller or temperature controller continues to regulate the reaction temperature at the last table entry. If you prefer for temperature control to be turned off at the end of the program, place a check mark in the box titled “Turn temperature control off when the program completes”.

**Pressure Program**

	Setpoint (torr)	Duration (min)
Step 1	760.0	10
Step 2	220.0	15
Step 3	100.0	25
Step 4		
Step 5		
Step 6		

### Pressure Program

The pressure in the reaction vessel, both vacuum and positive pressures, can be implemented using the pressure program table. The standard Infinity measures the reactor pressure, but the option of controlling reactor pressure is optional. Contact Ace Glass for additional information. This table is not enabled unless the pressure control option is installed in the controller.

	Reagent Port	Addition Volume (ml)	Addition Rate (ml/min)	Pause (min)	Refill Rate (ml/min)	Temp Limit (oC)	pH Limit	Volume Added (ml)
Step 1	B	125	100	0.0	150.0	50	7	116.182
Step 2	C	10	10	0.0	150.0			
Step 3				0.0	150.0			
Step 4				0.0	150.0			
Step 5				0.0	150.0			
Step 6				0.0	150.0			

**Stirring Program**

Step	Speed (rpm)	Duration (min)	Direction
Step 1	100	1	Clockwise
Step 2	50	0:00:58	Counter Clockwise
Step 3			Clockwise
Step 4			Clockwise

All programs run in parallel. Programs can be started simultaneously, or at different times.

To start a program, select Start from the Program menu. A sub-menu appears that allows the user to start individual programs, or to start all the programs simultaneously.

**Menu Options** - Commands under the Program menu include:

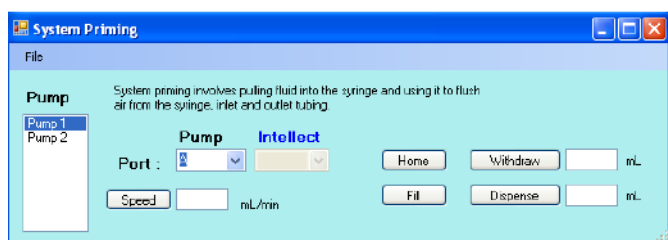

**Prime Syringe Pump Ports** - Selecting this option brings up a screen that allows the user to manually select syringe pumps ports and withdraw and dispense from the syringe. This feature is useful to purge air from inlet and outlet lines prior to starting a run.

**Start** – The start menu presents a sub-menu that allows the user to start individual programs for reagent addition, stirring, and chiller control. Also, all ramps can be started simultaneously by selecting the option to Start All Programs.

**Stop** – The stop menu presents a sub-menu that allows the user to stop individual running programs for reagent addition, stirring, and chiller control. Also, all ramps can be stopped simultaneously by selecting the option to Stop All Programs.

**Pause all Programs from Advancing to the Next Step** – Selecting this option allows all running program to complete the current step, but prevents them from advancing to the next step in the program. Note that this option does not pause a running program at the point where the pause is started. For example, if a temperature program is 5 minutes into a 15 minute step when the Pause feature is requested, the current step does not stop running, but rather continues until the full 15 minutes of the step has completed. It's at the end of the step when the pause feature becomes active and prevents the program from advancing to the next step. Running programs are stopped individually when they reach the end to the current active step. The Pause feature is disabled by selecting this menu option a second time. The reaction controller software has several edit and pause options, see the section titled Editing a Running Program.

**Reset Application** - The menu option becomes active after all running ramps have completed, or the ramps are manually stopped using the Stop menu option. This option must be selected to reset the application to a state where a new run can be entered.

**Save Programs** - This option saves the programs entered into the three program tables. The user is prompted for a method name to save the programs to.

**Recall Program** – The user is presented with list of saved methods. To recall a method, double click on the desired method name. To delete an existing method, single click on the method to select it, then click the Delete button.

**Recall Program** – The user is presented with list of saved methods. To recall a method, double click on the desired method name. To delete an existing method, single click on the method to select it, then click the Delete button.

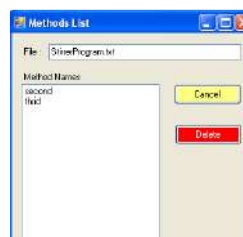

**The Infinity menu** opens a configuration window for the Infinity controller. This screen shows the current configuration of the Infinity controller.

## Editing a Running Program

There are two options for modify the progress of a running reaction controller program, the program can either be edited or paused.

Pausing a program allows the program to complete the currently active step, and then prevents the program from advancing to the next step while the pause is active. A program pause is requested by selecting the menu option Pause All Programs From Advancing to the Next Step from the Program menu.

The screenshot displays four active program windows:

- Reagent Addition Program:** Shows a table with 6 steps. Step 1 is active, showing Reagent Port B, Addition Volume 1 ml, Addition Rate 0.2 ml/min, and Volume Added -0.521 ml.
- Temperature Control Program:** Shows a table with 6 steps. Step 1 is active, showing Starting Temp 10°C, Ending Temp 20°C, and Step Time 0:00:41.
- Stirring Program:** Shows a table with 6 steps. Step 1 is active, showing Starting RPM 100, Ending RPM 200, and Step Time 0:01:39.
- Custom Pressure (Torr):** Shows a table with 6 steps. Step 1 is active, showing Starting Pressure 760 Torr, Ending Pressure 500 Torr, and Duration 0:02:40.

For example, in the above screen, a solvent addition, temperature, stirring, and pressure program are all running. If a Pause request is issued at this point all programs will continue to run until they complete the active step, which in this case is Step 1 for all programs.

The screenshot shows the same four program windows, but they are now in a paused state:

- Temperature Control Program:** Step 1 is now labeled "Paused" in the Step Time column.
- Stirring Program:** Step 1 is now labeled "0:00:55" in the Step Time column.
- Custom Pressure (Torr):** Step 1 is now labeled "0:01:56" in the Duration column.

A prominent red banner at the bottom of the interface reads "Programs are PAUSED".

In the screen above, the temperature program has completed its active step and indicates that it is in a Paused state by displaying the word "Paused" in the Step Time line. The stirring and the pressure programs will continue to run until their current step completes, and then they also will pause. A paused state is released by selecting the menu option Release Program Pause from the Program menu. When the pause is released, programs resume by starting the next program step.

Programs can be edited while they are running, but editing a step that has not started and editing the currently running step are performed differently.

Temperature Control Program

This temperature ramp is applied to the:  Chiller  Temperature Controller

	Starting Temp (oC)	Ending Temp (oC)	Step Time (min)	Hold Time (min)
▶ Edit	10	20	0:00:51	0.0
Step 2	20	30	1	0.0
Step 3	30	40	1	0.0
Step 4				0.0
Step 5				0.0
Step 6				0.0

Turn temperature control off when the program completes

In the screen on the left, any of the values in steps 2 & 3 can be edited by typing in new values. The value of steps that have not started can be freely edited, and additional steps can be added at will.

Editing the active step is different. Step 1 is active, and when a step becomes active the title of that line is changed from “Step 1” to “Edit”.

Edit Active Temperature Step

Starting Temperature (current temperature)

Ending Temperature  C

Step Time  Min

Hold Time  Min

Temperature Control Program

This temperature ramp is applied to the:  Chiller  Temperature Controller

	Starting Temp (oC)	Ending Temp (oC)	Step Time (min)	Hold Time (min)
▶ Edit	10	20	0:00:16	0.0
Step 2	20	30	1	0.0
Step 3	30	40	1	0.0
Step 4				0.0
Step 5				0.0
Step 6				0.0

Turn temperature control off when the program completes

To edit the values of the active step, clicking on the word “Edit” that appears in the first column of the active line will cause an edit screen to appear above the program of interest. Enter new values of reach of the step parameters, then click on the Load Data button. The starting value, in this case Starting Temperature, cannot be set. When an edit occurs, the current value of the reactor is used as the starting value. Note, that the active step of a program continues to run according to the originally entered values until the new values are entered by clicking on the Load Data button.

Edit Active Temperature Step

Starting Temperature (current temperature)

Ending Temperature  45 C

Step Time  12 Min

Hold Time  5 Min

Temperature Control Program

This temperature ramp is applied to the:  Chiller  Temperature Controller

	Starting Temp (oC)	Ending Temp (oC)	Step Time (min)	Hold Time (min)
▶ Edit	10	20	Paused	0.0
Step 2	20	30	1	0.0
Step 3	30	40	1	0.0
Step 4				0.0
Step 5				0.0
Step 6				0.0

Turn temperature control off when the program completes

Temperature Control Program

This temperature ramp is applied to the:  Chiller  Temperature Controller

	Starting Temp (oC)	Ending Temp (oC)	Step Time (min)	Hold Time (min)
▶ Edit	20.0	45.0	0:11:55	5.0
Step 2	20	30	1	0.0
Step 3	30	40	1	0.0
Step 4				0.0
Step 5				0.0
Step 6				0.0

Turn temperature control off when the program completes

If the active step completes while the user is editing the step, the active step goes into a ‘Paused’ state, then when new parameters are loaded to the step, the step reformats and runs the edited step data.

Note that the active step of a syringe pump addition program can not be edited.

# Graphing

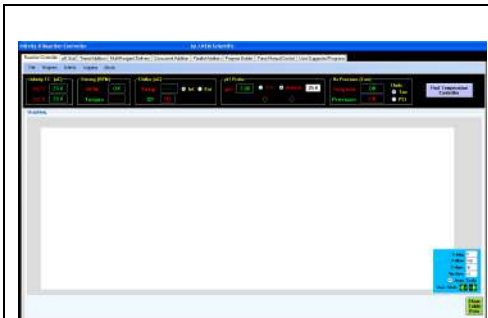

Run data can be displayed graphically on the main screen. To change to graphical display, click on the button  located on the bottom right of the screen. The software can display up to 3 graphs, each graph plotting different run parameters. The user can return to table display by clicking on the button labeled Show Table Data.

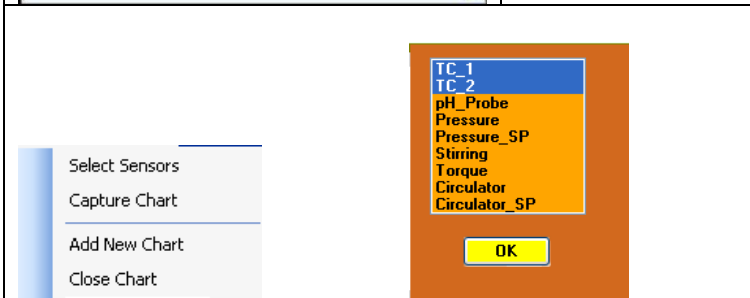

To start graphing, right click on the graph to bring up a context menu. Click on Select Sensors to display the list of activated sensors and instruments on the Infinity controller. Click on the sensors of interest (which become highlighted), then click the OK button.

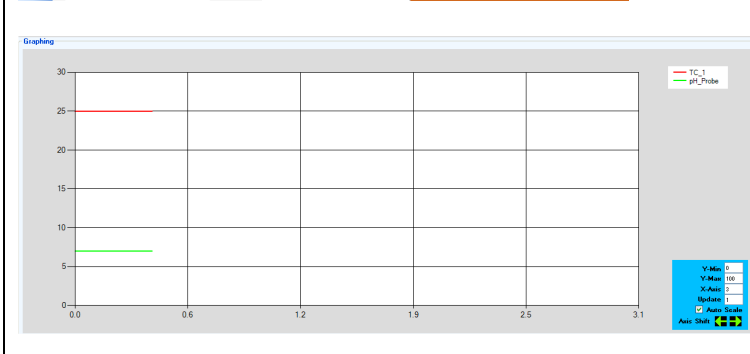

The selected sensors begin to plot. Additional sensors can be added to an active chart by performing the same process again.

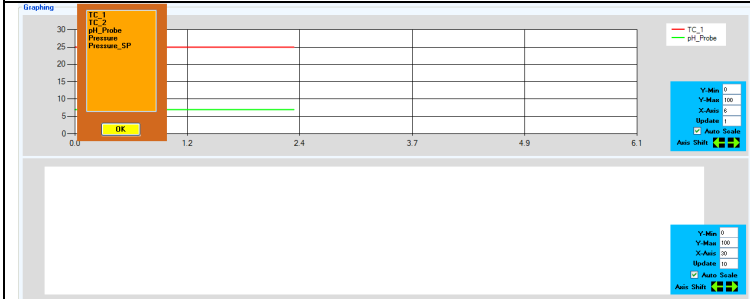

Up to three charts displaying different sensors can be displayed. To add a new chart to the window, right click on the existing chart, then from the context menu select 'Add New Chart'. A second chart appears.



From the sensor selection box, select the sensors to plot in the new chart, then click OK. This process can be repeated again to add a third independent chart to the window. Charts can be removed from the window by right clicking on the chart to remove, then selecting Close Chart.

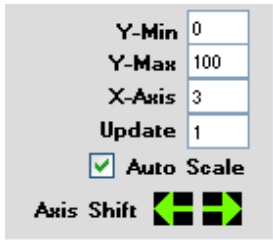

By default, the X-axis length is 30 minutes long, and the update time is 10 seconds. The length of the X axis and the update frequency can be changed by entering the desired values.

When Auto Scale is checked, the scale of the Y- axis is automatically adjusted to display all data points. To manually set the Y-axis scale, uncheck Auto Scale, then enter the desired Y-axis minimum and maximum values in the Y-Min and Y-Max boxes provided.

The chart can be shifted to the right or left to display data points that have scrawled out of view on the chart by click the Axis Shift right and left arrows.

Other charting options are available by right clicking on the chart of interest, then selecting the desired option.

Capture Chart – Task a screen shot of the current chart, then prompts for a name to save the chart to. This is useful to capture a chart at a specific point in time.

## Data Logging

Reaction data, for any selected sensors or instruments, can be logged to the PC. Data can be logged in both GMP compliant and GMP non-compliant format.

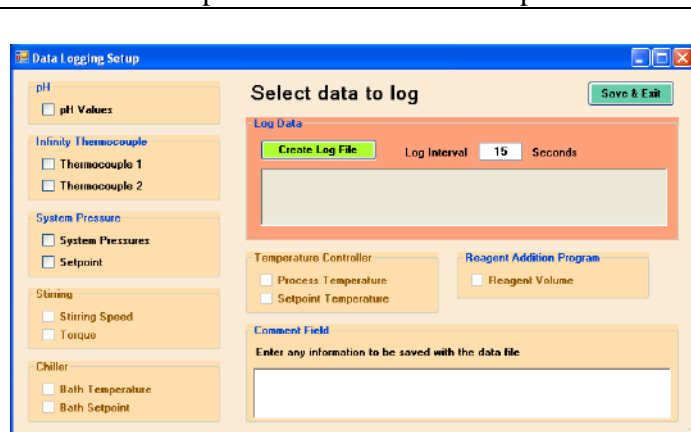

Run-time data is saved as a .csv file, which is directly readable by Excel.

To start logging, select Setup from the Logging menu. A screen appears that shows the run-time parameters that can be logged, only sensors that enabled can be logged. Check the boxes for the sensors to log.

By default the interval between logged points is 15 seconds, but this can be changed to any value from 1 to 10,000 seconds.

Clicking the Create Log File prompts the user to enter a filename for logging. Enter a file name, then click the Save and Exit button to begin logging.

Prior to logging, the user is prompted as to whether data should be logged in a GMP compliant or non-compliant format (the difference between these two formats is explained later). Select the desired option and logging will start.

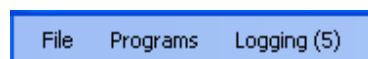

While the system is logging, the Logging menu shows the number of points saved to file (in this case, 5 points).

GMP compliant data logging creates a read-only Excel file with embedded encryption codes. The data in the file can be displayed, and printed (plotted) from Excel, but it cannot be edited without corrupting the encryption keys. The encryption keys are used to determine if the file has been modified since the time it was originally created.

Non-GMP compliant data logging creates a standard Excel data file than can to displayed, printed and plotted.



If GMP compliant data logging is selected, a login screen is presented where the User can be selected from a dropdown list. The selected user must enter their user name and password, then click OK to start logging

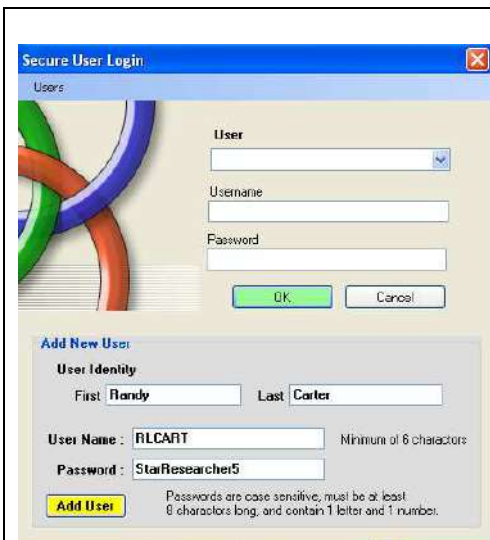

New users can be added to the User database by selecting Add New Users from the Users menu. In the screen that appears, enter the literal first and last name of the user, a UserName (which becomes part of the logged file identity), and a case sensitive password. When all information is added, click the Add User button.

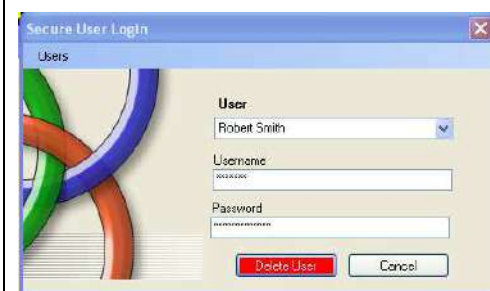

Users can be deleted by selecting Delete Users from the Users menu. To delete a user, select the user from the drop down menu, enter the UserName and password and click the Delete User button.

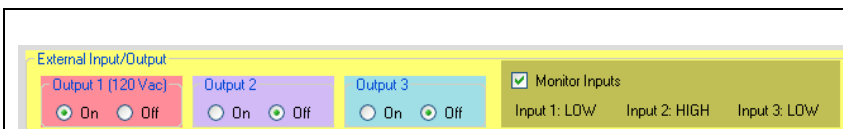

### External Inputs and Outputs

The infinity controller can be highly customized with up to 16 high current outputs and 16 digital inputs. Typically, the Infinity controller has three outputs and three inputs configured. These controls provide an interface for the user to manually control the state of the outputs and read the state of the inputs. The state of the inputs and outputs can also be part of an automated program, contact J-KEM Scientific for additional information. To control the state of the outputs, specify the state desired using the radio buttons provided. Output 1 typically controls the state of a 120 (230) Vac outlet on the back of the controller, while outputs 2 & 3 are open collector outputs. By checking the check box titled 'Monitor Inputs', the state of the three inputs will be continuously updated on screen.

# Vacuum Regulator Setup

## Hardware Setup for an Evacuation Only (single valve) Controller

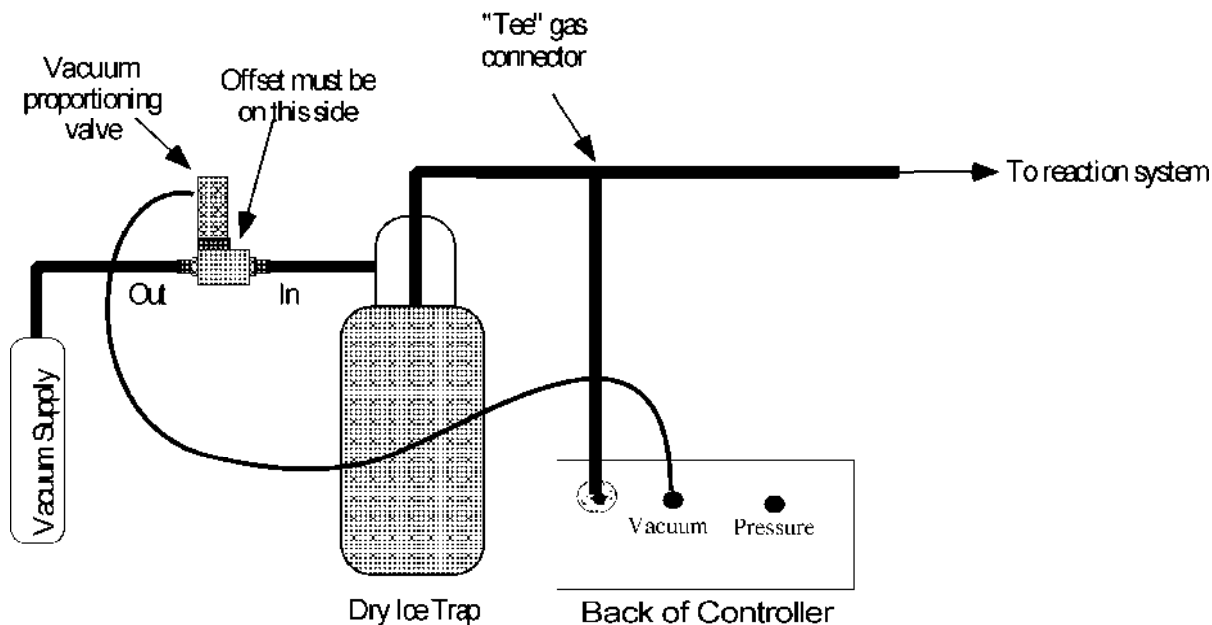

**NOTE:** The vacuum proportioning valve is very sensitive to contaminants which can cause the valve to stick. A high efficiency trap must be placed between the proportioning valve and the reaction system to protect the valve. Proportioning valves are not warranted against failure.

1. Connect the outlet of the vacuum proportioning valve to the vacuum source. The vacuum valve will be one of two types. It will either have a silver coil on top of a silver body (PSV2 - PSV5 valves), or a silver coil on top of a black body (PSV6 – PSV 8 valves). If the valve has a silver body, note that the cylindrical portion of the valve is offset from the square body of the valve, connect the fitting closest to the cylinder to the vacuum source. Connect the other fitting to the outlet of a dry ice trap. If the valve has a black body, connect the port labeled “OUT” to the vacuum source and the port labeled “IN” to the dry ice trap.
2. Plug the proportioning valve’s gray cord into the electrical connector on the back of the Infinity regulator labeled “Vacuum”. Make sure the cable locks into position.
3. Connect the vacuum sensing inlet on the back of the Infinity regulator (a threaded or Swagelok fitting) to a Tee connector between the inlet of the trap and the piece of equipment that pressure is being regulated in. Wide bore tubing should be used to make all pressure connections. The length of tubing between the Infinity regulator’s vacuum sensing inlet and the reactor under vacuum should be kept to a minimum (no longer than 6 feet, but under 3 feet will yield more accurate results). To set up the regulator, simply connect a USB cord between the Infinity-II regulator and the Netbook PC controller.

## Hardware Setup for a Dual Control (dual valve) Controller

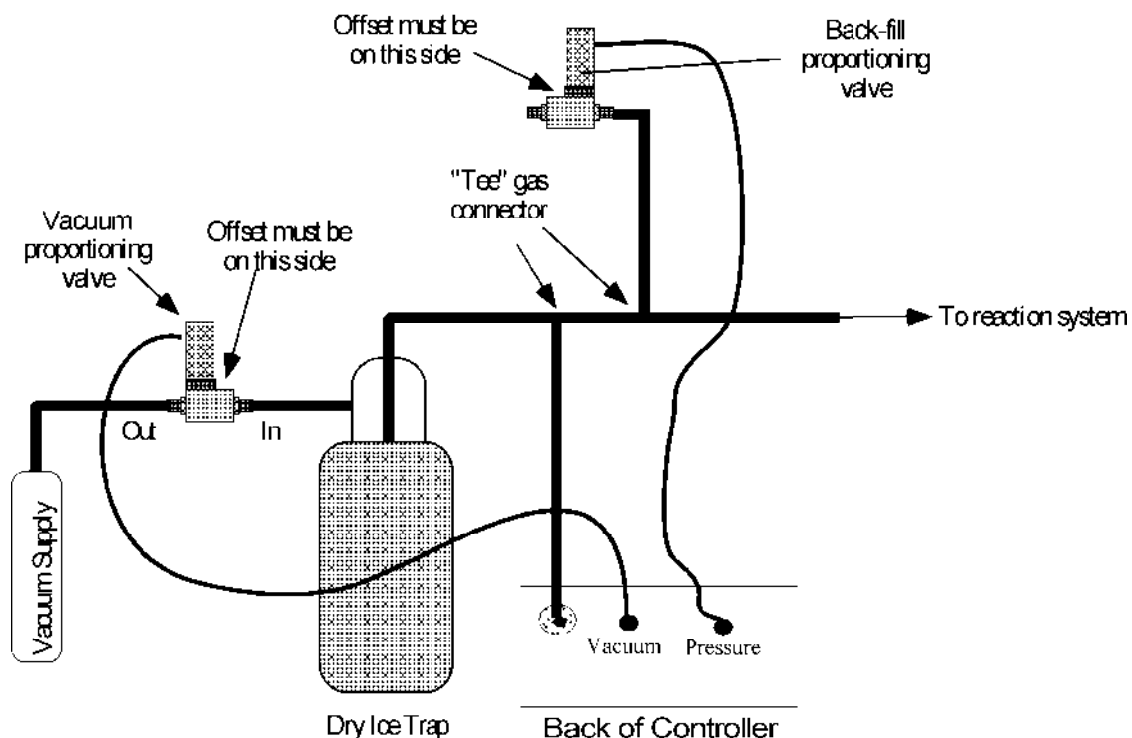

**NOTE:** The vacuum and atmosphere proportioning valves are very sensitive to contaminants which cause the valves to stick. A high efficiency trap must be placed between the vacuum proportioning valve and the reaction system to protect the valve. Proportioning valves are not warranted against failure.

1. Connect the outlet of the vacuum proportioning valve to the vacuum source. The vacuum valve will be one of two types. It will either have a silver coil on top of a silver body (PSV2 - PSV5 valves), or a silver coil on top of a black body (PSV6 – PSV 8 valves). If the valve has a silver body, note that the cylindrical portion of the valve is offset from the square body of the valve, connect the fitting closest to the cylinder to the vacuum source. Connect the other fitting to the outlet of a dry ice trap. If the valve has a black body, connect the port labeled “OUT” to the vacuum source and the port labeled “IN” to the dry ice trap.
2. Plug the vacuum proportioning valves gray cord into the electrical connector on the back of the Infinity regulator labeled “Vacuum”. Make sure the cable locks into position.
3. Plumb the back-fill proportioning valve into the system as shown. If the system uses a silver PSV2 – PSV5 valve, then leave the fitting that is furthest from the top coil open to atmospheric pressure (see drawing above). If the uses a PSV6 –PSV8 valve, then leave the port labeled “IN” open to the air.
4. Plug the back-fill proportioning valves gray cord into the electrical connector on the back of the Infinity regulator labeled “Pressure”. Make sure the cable locks into position.
5. Make the gas connections shown in the drawing above. Wide bore tubing should be used to make all pressure connections. The length of tubing between the Infinity controller’s pressure sensing inlet and the reactor under control should be kept to a minimum (no longer than 6 feet, but under 3 feet will yield more accurate results).

## KEM-Rx Instrument Control

Occasionally, it's useful to automate and data log only external instruments, like a recirculating chiller and overhead stirrer. The analog sensors of the Infinity controller, and the fluid addition features of the syringe pump are not needed, only the instrument control features of KEM-Rx software. When KEM-Rx is started without the Infinity controller or the syringe pump the controls for a chiller and stirrer are presented to the user.

### Hardware Setup

To use KEM-Rx software only for external instrument control, neither the Infinity controller or the syringe pump can be connected to the PC.

If a stirrer is used, directly connect the serial port from the stirrer to one of the PC's USB ports.

If a chiller is used, directly connect the serial port from the chiller to one of the PC's USB ports.

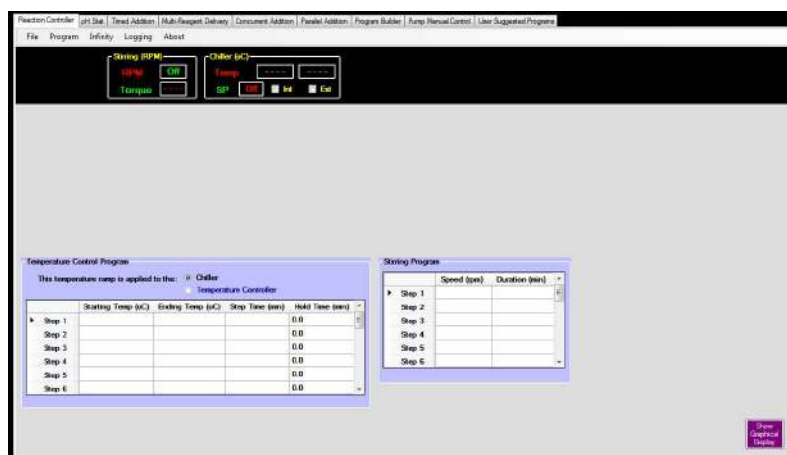

Start KEM-Rx software. You'll be presented with a message that neither the Infinity controller or syringe pump were detected on startup, then the screen at the left appears. All of the control, ramping, and data logging features that are available for the chiller and stirrer in the Reaction controller program are available when being run in this mode. See the Reaction Controller Program section for a description of these features.

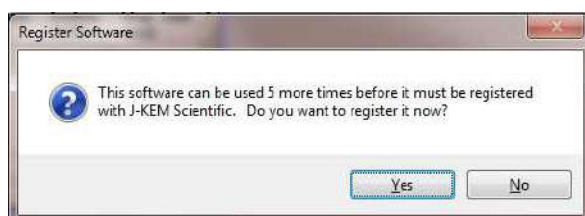

KEM-Rx requires that the user enter a software key, one time. The software can be used five times before the validation key must be entered. Prior to entering the validation key, the following screen appears on startup.

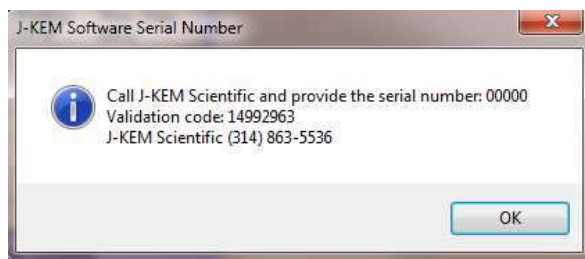

If you elect to register the software, this screen appears. Record both the Serial number and the Validation code, then provide both to J-KEM to receive the software unlock key. Once the key is entered, these screens will no longer appear on startup.

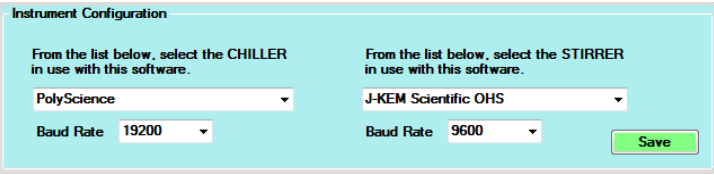
 <p>Instrument Configuration</p> <p>From the list below, select the CHILLER in use with this software.</p> <p>PolyScience</p> <p>Baud Rate 19200</p> <p>From the list below, select the STIRRER in use with this software.</p> <p>J-KEM Scientific OHS</p> <p>Baud Rate 9600</p> <p>Save</p>	<p>The brand of chiller and stirrer is typically stored in memory of the Infinity controller, but when used in ‘software only mode’, the user must tell the software which chiller and stirrer is in use. These selections are saved to memory, so they only need to be set one time.</p>
<p>To specify the chiller and stirrer, select Instrument Configuration from the Infinity menu. From the dropdown lists, select the correct chiller and stirrer and also the appropriate communication baud rates, then click Save to store these instruments selections.</p>	

## The pH Stat Program

This program adjusts and then continually maintains a solution pH at a user entered value by adding either an acidic or basic reagent as needed. If the system includes a single syringe pump, then either acid or base can be added, if it's a dual pump system, then the user has two options. Using pump 2, the program can add acid or base, whatever is not being added by pump 1, or pump 2 can add a reagent, other than acid or base, while pump 1 maintains the solution pH. If the system has a single syringe pump, then the group boxes for Pump 2 are disabled.

It is important that the pH input be calibrated periodically, and especially before starting an important experiment. See the section titled "Calibrating a pH Probe" at the end of this section.

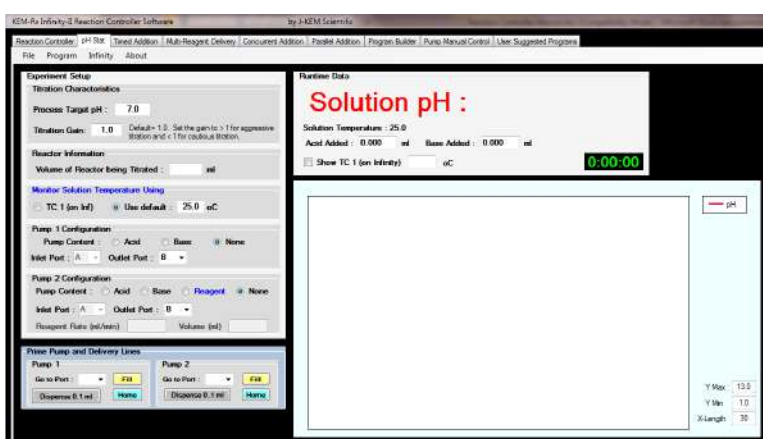

The pH control program requires that the chemist use *reasonable chemist experience* when setting the reaction up. For example, in most cases it's better to use 1 molar acid or base as the titrant, rather than 12 molar. Also, it is critically important that the outlet line be primed with reagent so that as soon as the pump dispenses a volume of reagent, the reagent is actually added to the reaction system. The outlet line should be placed directly in the solution itself so that even very small volumes of reagent are immediately added to the solution, rather than waiting for a drop to fall from the addition line that is suspended above the solution.

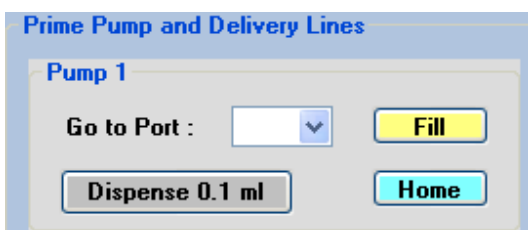

**Prime INLET Line** – Priming is the process of expelling all air from the Inlet, Outlet and syringe, and simultaneously filling these lines with reagent, prior to beginning a program. Connect a length of Teflon tubing from the reagent bottle (acid/base) to Port A on the pump's distribution valve. A box is provided with controls that allow both the inlet and outlet lines to be primed with reagent. As an example, assume that

the reagent is on Port A of the syringe pump and the reactor is connected to Port B. In the box titled Go to Port, select Port A. Click the Fill button and wait for the syringe to fill, then click the Home button, this should prime the inlet line. Now fill the syringe once again by clicking on the Fill button. Change the pumps port to Port B. Now click the Dispense 0.1ml button until the reagent completely fills the delivery line.

**Experiment Setup**

**Titration Characteristics**

Process Target pH :

Titration Gain:  Default= 1.0. Set the gain to > 1 for aggressive titration and < 1 for cautious titration.

**Reactor Information**

Volume of Reactor being Titrated :  ml

**Monitor Solution Temperature Using**

TC 1 (on Inf)  Use default :  oC

**Pump 1 Configuration**

Pump Content :  Acid  Base  None

Inlet Port :  Outlet Port :

**Pump 2 Configuration**

Pump Content :  Acid  Base  Reagent  None

Inlet Port :  Outlet Port :

Reagent Rate (ml/min)  Volume (ml)

**Process Target pH** – Enter the pH to adjust and maintain

the solution pH to.

**Experiment Setup**

Process Target pH :

When entering a new pH setpoint (target pH), the new pH value does not take effect until the “Load New Value” button is clicked. This value can also be changed while a titration is running.

**Titration Gain** – Determines how aggressively acid or base is added to the reaction in order to adjust its’ pH. For cautious titration use a value < 1, for aggressive titrations, use a value > 1. This value can also be changed while a titration is running.

**Volume of Reaction** – Enter the volume of the reaction being titrated.

**Monitor Solution Temperature Using**

TC 1 (on Inf)  Use default :  oC

**Solution Temperature** – pH measurements are a function of solution temperature. You have the option of connecting a type T thermocouple to the Infinity controller and placing it in the solution be monitored, or simply entering a default temperature for the reaction. If a thermocouple is connected and placed in solution, click the radio button titled TC 1. If you do not want to place a thermocouple in solution, then check the radio button titled User Default, then enter the solution temperature in the box provided.

**Pump 1 Configuration**

Pump Content :  Acid  Base  None

Inlet Port :  Outlet Port :  Acid Molarity

**Enter the Reagent Identity.** Specify whether syringe pump 1 has acid or base and is being added to the monitored solution. The reagent (acid/base) must always be connected to Port A on the pump’s distribution valve. You must specify the port that the reactor is connected to in the box titled Outlet Port. Enter the molarity of the acid or base being added.

If your system has a dual syringe pump, then pump 2 can be used to add either acid or base, or a non-acid/base reagent.

**Pump 2 Configuration**

Pump Content :  Acid  Base  Reagent  None

Inlet Port :  Outlet Port :  Base Molarity

Reagent Rate (ml/min)  Volume (ml)

**Using Pump 2 to Add Acid or Base.** Pump 2 can be used to

add the opposite reagent being added by pump 1. If pump 1 is adding acid, then pump 2 can add base. Conversely, if pump 1 is adding base, then pump 2 can add acid. With both acid and base available, the system can maintain a target solution pH under any reaction condition. To add acid or base, click on the appropriate radio button to identify the desired reagent. Enter the molarity of the reagent in use.

**Pump 2 Configuration**

Pump Content :  Acid  Base  Reagent  None

Reagent Inlet Port :  Outlet Port :

Reagent Rate (ml/min)  Volume (ml)

**Using Pump 2 to Add a Reagent.** If pump 1 is used to add

acid or base, then pump 2 is free to add any other reagent to the reaction mixture. For example, if an organic bromination is being run, pump 2 can add bromine while pump 1 titrates the mixture with base to quench the HBr generated in the bromination. Another example is for pump 2 to add a nutrient solution to an enzymatic reaction, while the acid, or base in pump 1 is used to maintain the reaction at the desired

pH. To add a reagent, click on the Reagent radio button. When the Reagent button is selected, two text boxes at the bottom of the Pump 2 Configuration box are enabled that allow the user to enter the addition rate and the total volume of reagent to add.

Acid Added :  ml Base Added :  ml Reagent (ml) :

When a reagent is added, a new box appears in the Run Time Data windows that shows the volume of reagent added to the reaction in real time.

### Menu Items –

Program -> Show System pH – Selecting this option causes the program to begin reading the pH probe and displaying the result on screen. This provides a way to see system pH without starting the pH stat program.

Program -> Start Control – This starts the pH stat program.

Program -> Pause – This pauses the addition of acid or base when the pH stat program is running.

Program -> Resume – This resumes a paused pH stat program.

Program -> Stop Control – This stops a running pH stat program.



Infinity -> Infinity Configuration – This shows the sensor configuration of the Infinity controller and presents the option to calibrate the pH probe.

The runtime screen shows the current solution pH, the total run time, and the total volume of acid and base added. During the course of a run, the volume displayed in the Acid Added and Base Added text boxes can be reset to a value of 0.0 ml by right clicking on the appropriate box, then selecting Reset Volume.

The pH of the solution is displayed in real time on the chart. X- and Y- axis scales can be adjusted using the text boxes to change these scales on the lower right of the chart.

### Calibrating a pH Probe



To calibrate the pH probe, select Calibrate pH Probe from the Infinity menu. Enter the pH values of both the acidic and basic standards and the temperature of the buffers in the text boxes provided.

Step 1 Place the pH probe in the acidic buffer and allow it to equilibrate to the buffer. While the probe is in the buffer, the millivolt reading of the probe is displayed, when the reading stabilized to a relatively constant value, click the Accept button to record this reading.

Step 2 Place the probe in the basic buffer. Again the display shows the millivolt reading of the probe and once it stabilizes to a constant value, click the Accept button to record the reading.

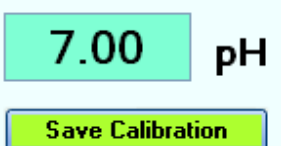

After calibrating on the basic buffer, the display changes to show the calibrated pH reading of the probe. The probe can be placed in both buffers to verify its calibration, when satisfied with the results, click the Save Calibration button.

# The Timed Addition Program

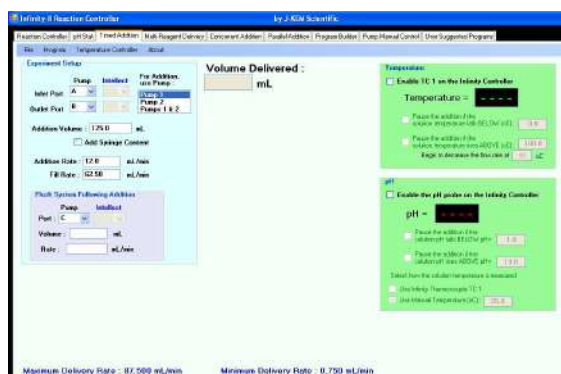

The timed addition program allows the pump to add any volume of a single reagent at a user specified rate, optionally, the addition rate can be made a function of solution temperature and/or pH.

The range of possible flow rates depends on the syringe size. The allowable flow rate range for the current syringe is shown at the bottom of the screen in green text.

Run data can optionally be logged to a data file by selecting Log Addition Data from the Program menu. If this option

is selected, the user is prompted for data logging options, then a data file name. Logged data always includes time and volume added, then if the thermocouple and pH probe are enabled, these values are also logged.

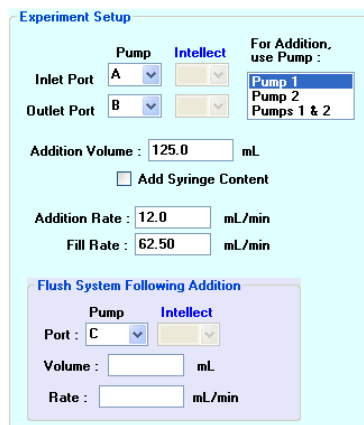

To set up a Timed Addition experiment, you must enter the following information.

**Inlet Port** – Select the port on the distribution valve reservoir of reagent is connected to.

**Outlet Port** – Select the port on the distribution valve that you want the reagent to be delivered out of.

**Addition Volume** – Enter the volume of reagent to deliver. This program will delivery any volume from any syringe since it handles refilling the syringe automatically. For example, this program can use a 5 ml syringe to delivery 35 mls of reagent.

**Add Syringe Content** – The function of this check box is explained at the end of this section.

**Addition Rate** – Enter the flow rate for the addition of the reagent. The maximum flow rate is shown at the bottom of the screen, there is no minimum flow rate. At the bottom of the screen is listed the “Minimum Continuous Delivery Rate, this is the minimum flow rate that the pump can deliver at with no interruption in the motion of the syringe plunger.

**Fill Rate** – This is the infusion rate that the program uses when filling the syringe. The program enters a default fill rate that is appropriate for non-viscose, or aqueous fluids, but the rate can be changed to any allowable flow rate for the pump. If the material being drawn into the syringe is viscose, then the default rate would attempt to fill the syringe at a rate faster than the material would flow into the syringe. In such cases, a slower fill rate, appropriate for the material can be entered. The fill rate can only be entered for single syringe dispenses. Dual syringe dispenses automatically calculate the slowest possible fill rate, depending on the dispense program entered.

## Flush Delivery Line

After the addition of the reagent is complete, it's often desirable to flush the reagent that remains in the delivery line into the reactor using a wash solvent. Depending on whether the outlet line is primed (see later), the reagent remaining in the delivery line is part of the reagent volume that was requested to be delivered, so normally, this reagent is flushed into the reaction system. The delivery line is flushed using the settings in the "Flush System Following Addition" box immediately after the addition of the reagent is complete. If you do not want to flush the reagent line, these boxes should be left empty.

**Port** – Select the port on the distribution valve that the flush solvent is attached to. This port can be open to the air (to flush with air) or it can be a reaction or wash solvent.

**Volume** – Enter the volume of the flush solvent used to purge the delivery line..

**Rate** – Enter the flow rate for the addition of the flush solvent.

## Dual Pump Systems Only

With a two pump system, the user has the option of selecting which pump to use for the delivery. The options are to use a single pump, either Pump 1 or Pump 2, or to use both pumps alternating delivery, which results in a continuous, delivery of reagent.

Select the pump to use in the selection box titled "For Addition Use Pump". The main difference between using a single pump (either Pump 1 or Pump 2) and using both pumps is the way the pump refills when additional reagent is needed. During a single pump addition, the syringe fills with reagent, delivers its content, and then pauses delivery, for about 7-10 seconds while it refills.

If this break in the continuous delivery of solvent is undesirable, the dual pump addition should be selected. A dual pump delivery fills one syringe while the other syringe is delivering, then just at the moment that the one syringe empties, the second syringe starts. This results in a continuous, uninterrupted delivery of the requested reagent.

If a single pump was used for the dispense and the option to flush the delivery line was selected, then only that pump is used for flushing. If both pumps were used, then the volume of the flush solvent is split between the two pumps and both pumps flush the delivery line.

## Add Syringe Content Feature

A special case for the Timed Addition Program occurs when you want to add the entire volume of a reagent, but you don't know what that volume is. For example, let's say you just worked up a reaction and the product of that reaction is in a flask. You don't know the exact volume of the reaction product, you simply want to "add it all, whatever the volume is". In this case, you can use the controls in the Prime group box to withdraw all the product into the syringe, then rather than entering a specific volume of reagent to add, click the check box titled "Add Syringe Content". The program will calculate the volume in the syringe and enter it into the Addition Volume text box automatically. The syringe can be washed, and the reagent left in the delivery line added to the reactor by using the feature of a Flush Step.



Once the appropriate addition data is entered into the Experiment Setup screen, to start the addition, select 'Start' from the Program menu on the Timed Addition tab. While a program is running, all other controls of the KEM-Rx application are disabled.

A Timed Addition program can be aborted by selecting Abort from the Program menu on the Timed Addition tab.

<p><b>Temperature</b></p> <p><input checked="" type="checkbox"/> <b>Enable TC 1 on the Infinity Controller</b></p> <p style="text-align: center;"><b>25.0</b></p> <p><input type="checkbox"/> Pause the addition if the solution temperature falls BELOW (oC): <input type="text" value="0.0"/></p> <p><input checked="" type="checkbox"/> Pause the addition if the solution temperature rises ABOVE (oC): <input type="text" value="100.0"/></p> <p>Begin to decrease the flow rate at <input type="text" value="80"/> oC</p> <hr/> <p><b>pH</b></p> <p><input checked="" type="checkbox"/> <b>Enable the pH probe on the Infinity Controller</b></p> <p style="text-align: center;"><b>7.00</b></p> <p><input type="checkbox"/> Pause the addition if the solution pH falls BELOW pH= <input type="text" value="1.0"/></p> <p><input type="checkbox"/> Pause the addition if the solution pH rises ABOVE pH= <input type="text" value="13.0"/></p> <p>Select how the solution temperature is measured</p> <p><input type="checkbox"/> Use Infinity Thermocouple TC 1</p> <p><input checked="" type="checkbox"/> Use Manual Temperature (oC): <input type="text" value="23.0"/></p>	<p><b>Temperature and pH Dependent Additions</b></p> <p>The addition of reagent can optionally be made a function of solution temperature or pH. That is, the user can enter temperature and pH limits that the solution must stay within for the reagent addition to continue. If the solution parameters fall outside of these limits, the addition is paused until the <i>out of limit</i> condition is corrected.</p> <p>To make the reagent addition dependent on solution temperature, connect a type T thermocouple to the Infinity controller and place it in the monitored solution. Click the check box titled <i>Enable thermocouple on the Infinity Controller</i>. You can enter either, or both, a lower and an upper temperature limit by checking the appropriate check box, then entering a limit temperature in the associated text box. If either the upper or lower limit is approached, the addition rate is first slowed, then if the limit is exceeded, the addition is paused. When the solution temperature comes back within the specified limits, the pump resumes reagent addition. For an over temperature condition, the user can additionally set the temperature where the addition rate of the reagent begins to be adjusted.</p>
<p>The text box titled <i>Pause the addition if the solution temperature rises ABOVE (oC)</i> is the temperature where the addition is completely halted. The temperature in the box titled <i>Begin to decrease the flow rate at</i> is the temperature where proportioning of the reagent flow rate begins. The flow rate is decreased linearly between these two temperatures in 10% increments.</p>	
<p>To make the reagent addition dependent on solution pH, connect a pH probe to the Infinity controller and place it in the monitored solution. Click the check box titled <i>Enable the pH probe on the Infinity Controller</i>. You can enter either, or both, a lower and an upper pH limit by checking the appropriate check box, then entering a limit pH in the associated text box. If either the upper or lower limit is approached, the addition rate is first slowed, then if the limit is exceeded, the addition is paused. When the solution pH comes back within the specified limits, the pump resumes reagent addition.</p> <p>Solution pH is a function of solution temperature. To use the thermocouple connected to the Infinity controller to measure the actual solution temperature, check the box titled <i>Use Infinity Thermocouple</i>, then place the connected thermocouple in the monitored solution. Alternately, the user can enter the solution temperature to use for pH measurements by checking the box titled <i>Use Manual Temperature</i>, then entering the temperature in the box provided.</p>	

## The Multi-Reagent Delivery Program

The Multi-Reagent Delivery program is selected by clicking on the tab of the same name. This program sequentially adds up to 16 reagents, at independent rates and volumes. For each step the user can specify the inlet and outlet ports, allowing multiple reagents to be added to multiple reactors.

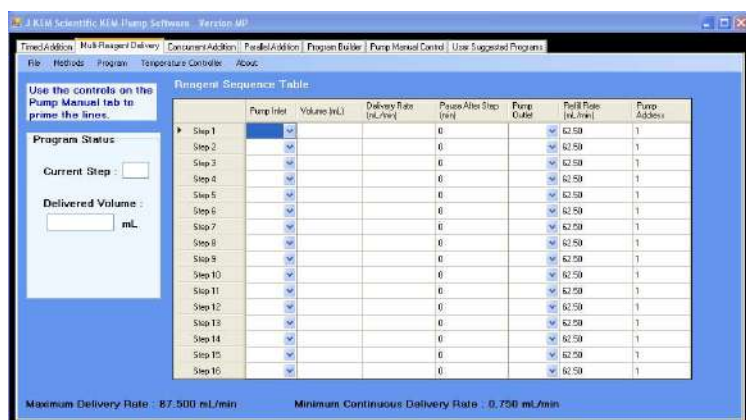

**Reagent Sequence Table** – The user can program up to 16 reagents to sequentially dispense. Fill in only the steps that are required. To create an addition step, start at Step 1 and select the port on the distribution valve that the first reagent is attached to. Enter the volume of reagent to add and the rate of reagent addition for the step. After the reagent addition is complete, the program can pause for a period of time by entering a Pause time in this column of the table. If the pause time is 0, the program immediately

proceeds to the next addition step. Select the port to dispense the reagent out of, this is the Outlet Port. The rate to fill the syringe can be optionally set, which is useful when filling the syringe with viscose reagents. The program continues until all of the additions defined in the table are complete. To reset the table for a new experiment, select Clear Sequence Table from the Program menu.

### SYR-2400 Only

If the SYR-2400 (dual pump) system is in use, the table adds an additional column titled Pump Address. In this column, the user can select which pump to use for each step, Pump 1 or 2.

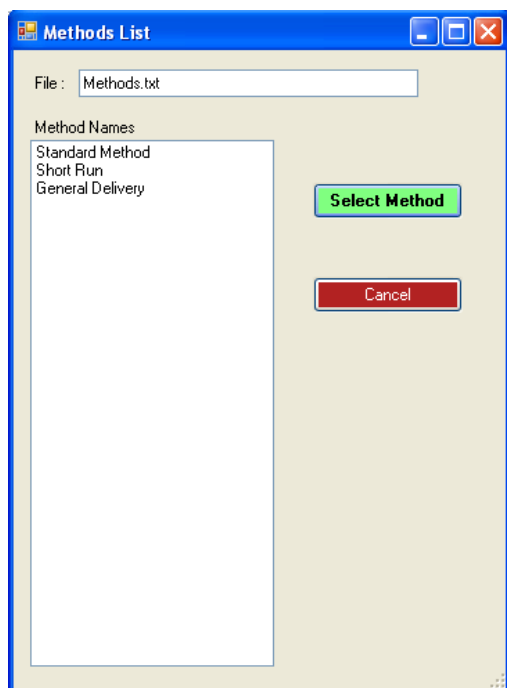

Once an experimental method is fully defined (by entering all the required information in the Reagent Sequence Table), you have 2 options. You can either start the experiment, or you can first save the method for future recall. The Methods menu contains three options:

**Save Method** – To save the method currently defined on the screens, choose this option. When selected, a pop-up window appears prompting for a method name. Enter the name, then click OK.

**Recall Method** – Selecting this option brings up a screen that lists all stored methods. Select the desired method, then click the Select Method button. The data from the selected method populates the Reagent Sequence Table.

**Delete Method** – Selecting this option brings up a screen that lists all stored methods. Select the method to delete, then click the Select Method button.

Before beginning an experiment, inlet and outlet lines can be manually primed by using the controls on the Manual Control tab. Once the system is in an appropriate starting condition, reselect the Multi-Reagent Delivery tab.

Once the desired addition sequence is defined in the Reagent Sequence Table, the experiment is started by selecting Start from the Program menu on the Multi-Reagent Delivery tab.

A running program can be terminated by selecting Abort from the Program menu.

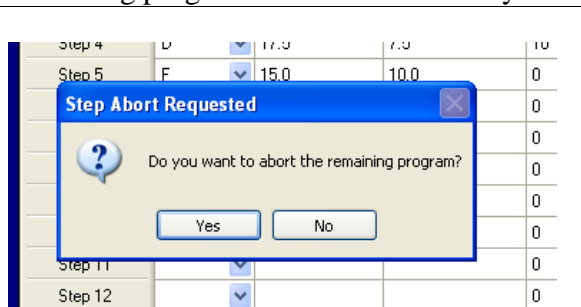

When Abort is selected a popup window offers the option of aborting all remaining steps or just the current step. If you select Yes, the running program with any remaining addition steps are aborted. If you select No, the current step is aborted and the program continues at the next addition step in the sequence. When No is selected, any reagent remaining in the syringe is returned to the appropriate reagent reservoir before starting the next step.



The function of a J-KEM temperature controller can be added to the software interface of the syringe pump. This provides a single interface for processes requiring temperature control during the pumping sequence. For a full description of the temperature control function, see the section titled "Temperature Controller Functionality".

## The Concurrent Addition Program

The Concurrent Addition Program only appears for Dual Syringe Pump systems. This program simultaneously runs two completely independent reagent delivery programs, one from each pump, in parallel with independent rates, port selection, and volumes.

The program can be used to simultaneously add two different reagents to the same process, or run two independent processes.

The screenshot shows the 'Concurrent Addition' tab in the software. It features two tables for configuring reagent delivery programs for Pump 1 and Pump 2. Each table has six steps with columns for Inlet Port, Volume (ml), Delivery Rate (ml/min), Outlet Port, Pause (min), and Refill Rate (ml/min). The Pump 1 table shows a delivery rate of 0.2 ml/min for Step 1. The Pump 2 table shows a delivery rate of 2.0 ml/min for Step 1. To the right of each table is a 'Run Status' box for that pump, currently showing 'Step 1' with a 'Step Volume' of 0.0 and a 'Pause Time' of ----.

### Reagent Addition Program

Each pump has an 8-step table that is used to construct the addition program for that pump. The addition programs for each pump run simultaneously, but independently of each other. The tables for each pump can have the same, or different, number of steps. A program terminates when the last user programmed step completes.

This screenshot shows a more detailed configuration of the concurrent addition program. The Pump 1 table is configured with five steps: Step 1 (Inlet Port A, Volume 12.3 ml, Delivery Rate 0.2 ml/min, Outlet Port C, Pause 1 min, Refill Rate 62.50 ml/min), Step 2 (Inlet Port B, Volume 10 ml, Delivery Rate 10 ml/min, Outlet Port C, Pause 0 min, Refill Rate 62.50 ml/min), Step 3 (Inlet Port B, Volume 10.0 ml, Delivery Rate 10.0 ml/min, Outlet Port A, Pause 0 min, Refill Rate 62.50 ml/min), Step 4 (Inlet Port B, Volume 10.0 ml, Delivery Rate 1.0 ml/min, Outlet Port A, Pause 0 min, Refill Rate 62.50 ml/min), and Step 5 (Inlet Port B, Volume 10.0 ml, Delivery Rate 1.0 ml/min, Outlet Port A, Pause 0 min, Refill Rate 62.50 ml/min). The Pump 2 table is configured with four steps: Step 1 (Inlet Port B, Volume 1.0 ml, Delivery Rate 2.0 ml/min, Outlet Port A, Pause 0 min, Refill Rate 62.50 ml/min), Step 2 (Inlet Port C, Volume 22.0 ml, Delivery Rate 2.0 ml/min, Outlet Port A, Pause 10 min, Refill Rate 62.50 ml/min), Step 3 (Inlet Port D, Volume 10.0 ml, Delivery Rate 1.0 ml/min, Outlet Port A, Pause 0 min, Refill Rate 62.50 ml/min), and Step 4 (Inlet Port B, Volume 10.0 ml, Delivery Rate 1.0 ml/min, Outlet Port A, Pause 0 min, Refill Rate 62.50 ml/min). The Run Status boxes for both pumps show 'Step 1' with a 'Step Volume' of 0.0 and a 'Pause Time' of ----.

The table at the left shows an example of a five step program entered for Pump 1 and a four step program entered for Pump 2. To start these programs, select Start from the Program menu on the Concurrent Addition tab. The Run Status box to the right of each of the pump programs updates during the run to show the status of that pump.

A running program can be aborted by selecting the Abort command from the Program menu. Aborting a program terminates the run for both pumps.

**Inlet Port** – The port on the distribution valve that the reagent reservoir is attached to.

**Volume (mL)** – The volume of reagent to deliver.

**Delivery Rate (mL/min)** – The rate to dose the reagent from the syringe pump.

**Outlet Port** – The port on the distribution valve that the reagent is delivered from.

**Pause (min)** – Following the addition of the reagent, or a temperature equilibration step, the process can pause for a set period of time before proceeding to the next step.

**Refill Rate (mL/min)** – The rate to fill the syringe can be optionally set. This is useful when filling the syringe with viscose reagents.

To clear both tables in preparation for another program, select Reset Program from the Program menu.

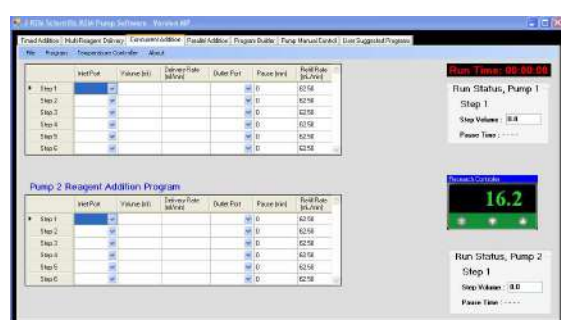

The function of a J-KEM temperature controller can be added to the software interface of the syringe pump. This provides a single interface for processes requiring temperature control during the pumping sequence. For a full description of the temperature control function, see the section titled “Temperature Controller Functionality”.

## Parallel Addition Program

This program uses a single pump (or dual pumps) to add a single reagent to multiple reactions in parallel at independent addition rates. For example, a common reagent can be attached to one of the pumps distribution valve ports (this is an inlet port), then delivery lines to 4 separate reactors are attached to 4 separate ports on the pumps distribution valve, (these will be outlet ports.).

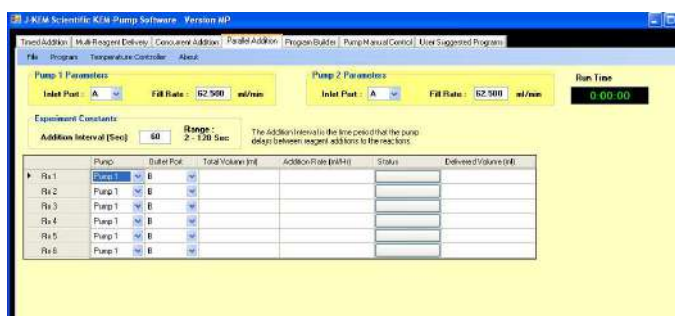

The pump fills the syringe with reagent from the common reagent port, and then sequentially accesses each of the ports connected to the 4 different reactors. When each reactor is accessed, the pump delivers the aliquot of reagent needed to satisfy the delivery rate specified by the user. This process continues until the volume of reagent has been delivered to each reactor at the rate specified.

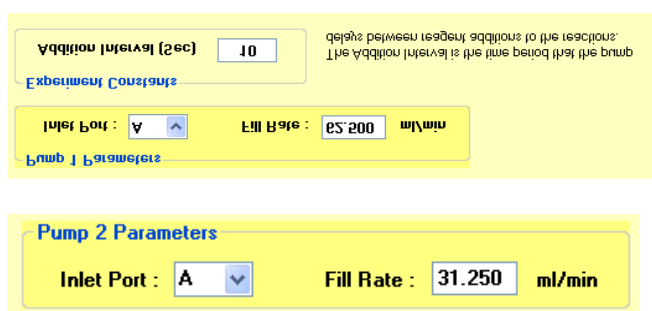

**Inlet Port** – Select the port that the common reagent is attached to.

**Fill Rate** – Enter the speed that the pump should use when refilling the syringe. This box contains the default speed of the pump, but for viscose reagents, the speed should be set to lower values.

**Additional Interval** – This program works by sequentially moving the distribution valve to the outlet port of each reactor and dispensing small amounts of reagent each time the port is accessed. The Addition Interval value is the amount of time that the pump pauses between addition cycles. One cycle is the process of the pump dispensing reagent

For dual pump systems, a group box for Pump 2 Parameters also appears. The second pump can be used to run a second series of independent additions of different or the same reactors as those accessed by pump 1.

from each active port. How often the pump starts an addition cycle determines the aliquot volume added to each reactor. For example, if the addition rate to a reactor is set to 1 ml/min, and the Addition Interval is set to 1 second, then 60 times per minute, the pump will add 16.7 ul aliquots of the reagent to the reactor (i.e.,  $16.7 \text{ ul} * 60 = 1 \text{ ml}$ ). If the addition rate to a reactor is set to 1 ml/min, and the Addition Interval is set to 5 seconds, then 12 times per minute, the pump will add 83.3 ul aliquots of the reagent to the reactor (i.e.,  $83.3 \text{ ul} * 12 = 1 \text{ ml}$ ). The shorter the Addition Interval, the smaller the aliquot of reagent that is added to a reactor, but short Addition Intervals may require many thousands of operations of the pump's distribution valve, causing it to age faster. In general, pick the longest Addition Interval that provides an aliquot addition volume suitable to the addition requirements. If the addition interval is shorter than the time needed for one addition cycle, the program will automatically change it to the shortest time possible.

	Pump	Outlet Port	Total Volumn (ml)	Addition Rate (ml/Hr)	Status	Delivered Volume (ml)
▶ Rx 1	Pump 1	B				
Rx 2	Pump 1	B				
Rx 3	Pump 1	B				

	Pump	Outlet Port	Total Volumn (ml)	Addition Rate (ml/Hr)	Status	Delivered Volume (ml)
▶ Rx 1	Pump 1	B	25.0	1.25	Ready	
Rx 2	Pump 1	C	12.5	2.0	Ready	
Rx 3	Pump 1	B				

	Pump	Outlet Port	Total Volumn (ml)	Addition Rate (ml/Hr)	Status	Delivered Volume (ml)
▶ Rx 1	Pump 1	B	25.0	1.25	Ready	
Rx 2	Pump 1	C	12.5	2.0	Ready	
Rx 3	Pump 1	D	12.5	0.50	Ready	

The reaction construction table populates with one less row than the number of ports on the pumps distribution valve.

Enter the volume of reagent to add and the rate of addition for each reactor in use. As the parameters for each reaction are entered, the Status label for that reactor turns to “Ready”.

**Pump 1 Parameters**  
 Inlet Port : A      Fill Rate : 31.250 ml/min

**Experiment Constants**  
 Addition Interval (Sec) : 10      The Addition Interval is the time period that the pump delays between reagent additions to the reactions.

**Running**

	Pump	Outlet Port	Total Volumn (ml)	Addition Rate (ml/Hr)	Status	Delivered Volume (ml)
▶ Rx 1	Pump 1	B	25	10.0	Ready	0.111
Rx 2	Pump 1	C	12.5	15.0	Ready	0.167
Rx 3	Pump 1	D	15.0	7.5	Ready	0.083

To start the additions, select Start from the Program menu. The table column titled Delivered Volume updates continuously during the course of the addition.

The only variable that can be changed while a run is in progress is the Total Volume of the reagent to all to a particular reactor.

**Pump 1 Parameters**  
 Inlet Port : A      Fill Rate : 31.250 ml/min

**Experiment Constants**  
 Addition Interval (Sec) : 10      The Addition Interval is the time period that the pump delays between reagent additions to the reactions.

**Running**

	Pump	Outlet Port	Total Volumn (ml)	Addition Rate (ml/Hr)	Status	Delivered Volume (ml)
▶ Rx 1	Pump 1	B	25	10.0	Pause	0.642
Rx 2	Pump 1	C	12.5	15.0	Ready	1.102
Rx 3	Pump 1	D	15.0	7.5	Ready	0.546

During a run, the addition to any reactor can be paused by clicking on the “Ready” button in the run-time table. When clicked the state of the button changes to Paused. To release the pause and resume addition to the reactor, click on the “Pause” button to set its state back to Ready.

### Menu Commands

**Program -> Start** Starts the experiment. When a program is started, all other experiment tabs are deactivated to prevent the user from starting a second syringe pump program while this experiment is running.

**Program -> End Experiment** A program naturally ends when the requested volume of reagent is added to each reactor. To end an experiment before all the reagent is added, select eh End Experiment menu option.

**Program -> Reset** After an experiment completes, select the Reset menu option to clear the table in order to enter data for a new experiment.

**Program -> Upload for Autonomous Run** Uploads a program to the syringe pump that allows the program to run even when the pump is disconnected from the PC. See the section titled Autonomous Syringe Pump Runs.

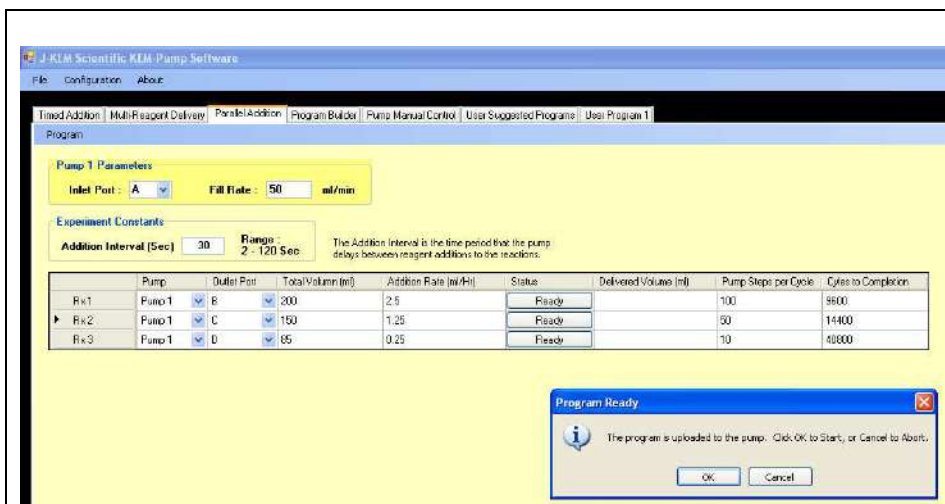

## Autonomous Syringe Pump Runs.

The feature uploads the syringe pump program to RAM memory in the syringe pump module, and then executes the program from the Pumps memory. When a program is run from the pumps RAM memory, the connection with the PC is disabled. After uploading the program to the pump, the KEM-Rx software can be

exited, since the pump no longer has communications with the PC. The advantage of this option is that it allows very long programs to be run without any need of being connected to the PC.

To use this feature:

- 1) Create the addition program in the table as normal.
- 2) Select Upload for Autonomous Run from the Program menu
- 3) In response to the message stating that the program was uploaded, click the OK button. Once the program starts in the pump, the KEM-Rx software can be exited, and the PC turned off. The program uploaded to the syringe pump is erased when power is turned off to the pump.



The function of a J-KEM temperature controller can be added to the software interface of the syringe pump. This provides a single interface for processes requiring temperature control during the pumping sequence. For a full description of the temperature control function, see the section titled "Temperature Controller Functionality".

# Program Builder

Program builder allows the user to arrange a sequence of pump commands in order to accomplish virtually any desired fluid motion/delivery program. Program builder can be run in either Local mode from the PC that operates the syringe pump, or Remote mode where a separate PC sends commands to the PC running the syringe pump. Remote mode is useful to incorporate the pump into a robotic or other automation application.

## Local Mode

The user creates a list of commands that the pump executes sequentially. This command list can include discrete pump actions, like change a port position, or dispensing a volume, and the list can include loops and delay times.

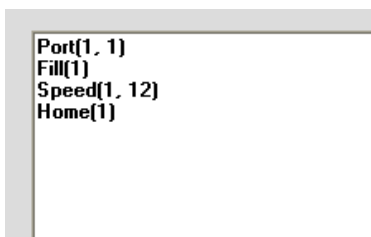
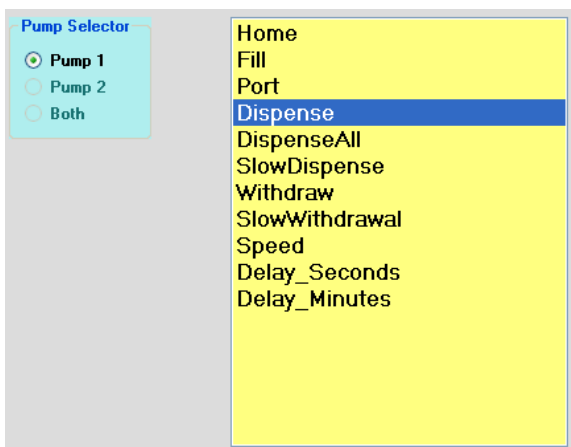
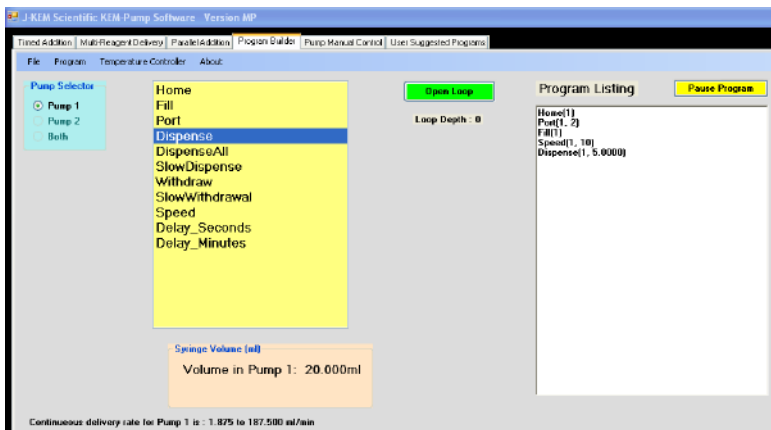

Program Builder consists of several controls, the first is the Command Selection Box. Depending on the options installed on your pump, the command selection box populates with the command available. For systems with a single pump, only the pump 1 pump selection is activated. For dual pump systems, to have pump 1 execute the command, click the Pump 1 radio box, to have pump 2 execute the command, click the Pump 2 radio button, and to have both pumps execute it, click the Both radio button. As an example, if Pump 1 were selected, when the Home command is clicked on, the resulting command is: Home(1) if Pump 2 were selected, the resulting command would be: Home(2), and if Both pumps are selected, the command would be Home(0). An address of 0 is a global address that causes all connected pumps to execute the command.

As command are selected from the Command Selection box, they appear in the Program box in the order that they were selected.

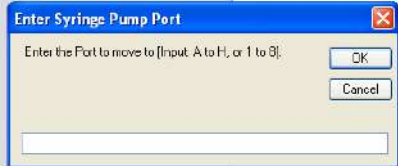
	<p><b>Home</b> – Instructs the selected pump to Home, which expels the entire content of the syringe. Remember – for multi-pump systems, you must select the pump (Pump 1, Pump 2, or Both) to perform the action before clicking on any command in the Command Selection box.</p>
	<p><b>Fill</b> – Instructs the selected pump to Fill the syringe to its maximum volume.</p>
	<p><b>Port</b> – When the Port command is clicked, an input box opens to prompt the user for the port to go to.</p>
	
	<p>Enter the desired port, then click OK</p>

**Dispense** - Causes the pump to dispense the requested volume. An input box opens prompting the user to input the volume to dispense. If a volume is entered that is greater than the current syringe volume, only the content of the syringe is dispensed, then the additional requested volume is ignored. If a volume is entered that is greater than the size of the syringe, an error message is displayed prompting the user to enter a volume no greater than the size of the syringe.

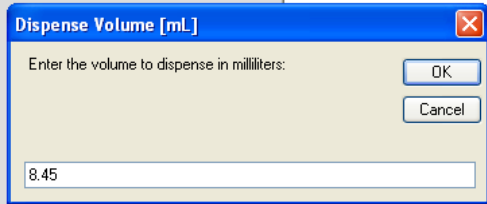

**DispenseAll** – Causes the pump to dispense the entire user entered volume, independent of what is the current volume or the size of the syringe. When selected, the DispenseAll command first prompts the user to enter the volume to dispense, it then prompts the user to enter the port on the distribution valve that the reagent is connected to. This command works by first using the current content of the syringe to dispense the requested volume. If that volume is less than the requested volume, then the pump positions the valve to the port the reagent is connected to, and continues to refill and dispense the reagent until the requested volume is dispensed. When this command completes, the volume in the syringe is 0.0 ml.

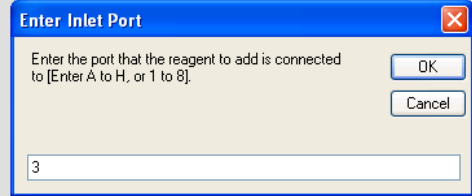
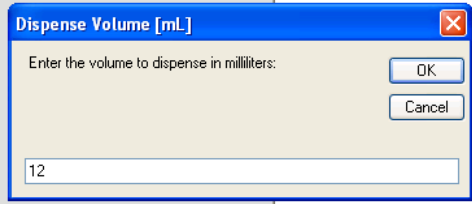

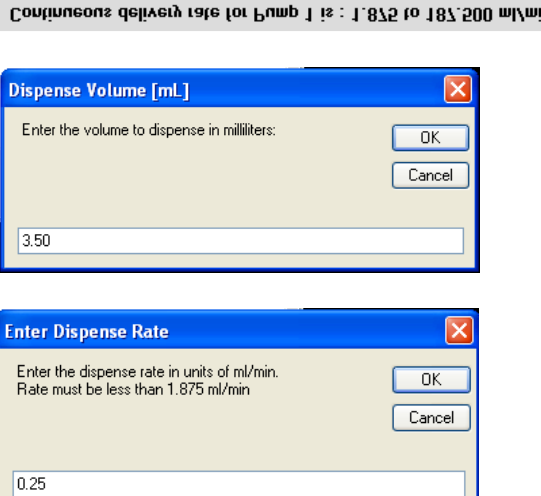
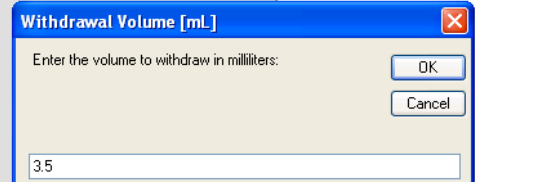
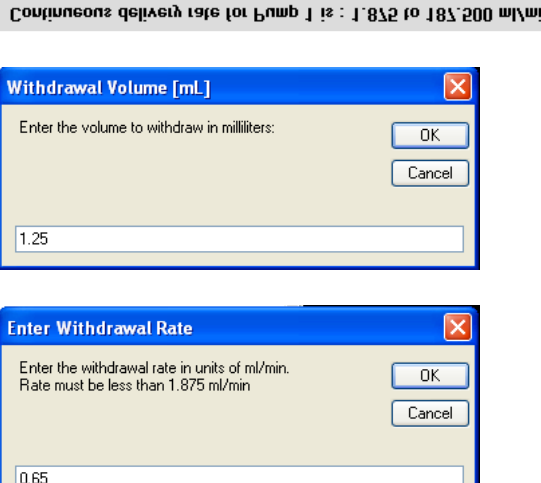
<p><b>SlowDispense</b> – The syringe pump has two delivery modes, continuous mode and step mode. When possible, continuous delivery mode is the best because it dispenses a continuous stream of fluid with no pauses or gaps, but at very low flow rates, continuous mode does not operate. At the bottom of the form, KEM-Rx shows the range of flow rates that can be achieved using continuous delivery mode, rates below the minimum continuous delivery rate must use step delivery mode. In step mode the pump delivers small aliquots of fluid once per second to achieve the desired flow rate. There is no lower limit to the flow rate in step mode. When SlowDispense is selected, you'll be prompted to enter the volume to deliver and dispense rate in units of ml/min.</p>	 <p>The screenshot shows two dialog boxes for the SlowDispense mode. The first dialog, titled "Dispense Volume [mL]", prompts the user to "Enter the volume to dispense in milliliters:" and has a text input field containing "3.50". The second dialog, titled "Enter Dispense Rate", prompts the user to "Enter the dispense rate in units of ml/min. Rate must be less than 1.875 ml/min" and has a text input field containing "0.25". Both dialogs have "OK" and "Cancel" buttons.</p>
<p><b>Withdraw</b> – Causes the pump to withdraw the entered volume from the currently selected syringe pump port. If the volume entered is greater than the volume of the syringe, a message is displayed prompting the user to enter a smaller volume.</p>	 <p>The screenshot shows a dialog box titled "Withdrawal Volume [mL]" with the prompt "Enter the volume to withdraw in milliliters:". The text input field contains "3.5". There are "OK" and "Cancel" buttons.</p>
<p><b>SlowWithdrawal</b> – The syringe pump has two delivery modes, continuous mode and step mode. When possible, continuous delivery mode is the best because it withdraws a continuous stream of fluid with no pauses or gaps, but at very low flow rates, continuous mode does not operate. At the bottom of the form, KEM-Rx shows the range of flow rates that can be achieved using continuous delivery mode, rates below the minimum continuous delivery rate must use step delivery mode. In step mode the pump withdraws small aliquots of fluid once per second to achieve the desired flow rate. There is no lower limit to the flow rate in step mode. When SlowWithdrawal is selected, you'll be prompted to enter the volume to withdraw and the withdrawal rate in units of ml/min.</p>	 <p>The screenshot shows two dialog boxes for the SlowWithdrawal mode. The first dialog, titled "Withdrawal Volume [mL]", prompts the user to "Enter the volume to withdraw in milliliters:" and has a text input field containing "1.25". The second dialog, titled "Enter Withdrawal Rate", prompts the user to "Enter the withdrawal rate in units of ml/min. Rate must be less than 1.875 ml/min" and has a text input field containing "0.65". Both dialogs have "OK" and "Cancel" buttons.</p>

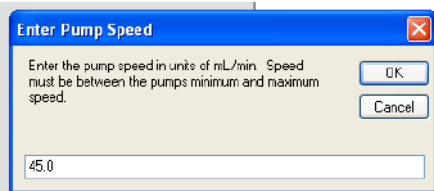
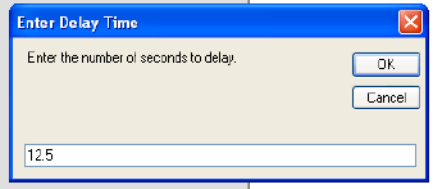
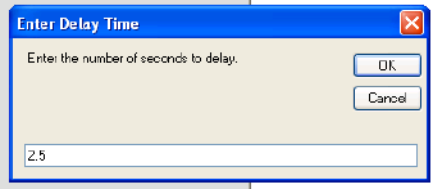
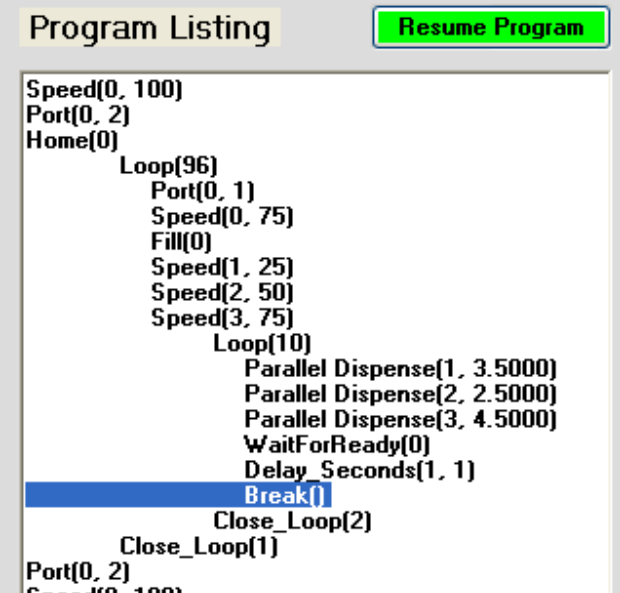
<p><b>Speed</b> – Causes the pump to set the speed for withdrawals and dispenses to the user entered value. Speeds are set in units of ml/min. The entered speed must be between the minimum and maximum delivery rate for the pump shown on the bottom of the KEM-Rx screen.</p>	
<p><b>Delay_Seconds</b> – Causes the pump program to insert a delay for the user entered amount of time before continuing to the next pump command. Times are entered as seconds and can be floating point numbers in the range of 0.001 to 20,000,000. For delays greater or equal to 1 second, the program displays a digital clock that shows the amount to time remaining in the delay. For delays less than 1 second, the digital clock is not displayed.</p>	
<p><b>Delay_Minutes</b> – Causes the pump program to insert a delay for the user entered amount of time before continuing to the next pump command. Times are entered as minutes and can be floating point numbers in the range of 0.001 to 20,000,000. During the delay, the program displays a digital clock that shows the amount to time remaining in the delay.</p>	
<p><b>Break</b> – When the Break command appears in a program, the program will run up to the command and then halt execution. The program remains at the Break command until the user clicks the “Resume Program” button appearing at the top of the screen</p>	

**Beep** – Causes the computers audio system to play a *beep* sound as a warning or to capture the users attention. When prompted, enter the number of Beeps to play when the command is encountered.

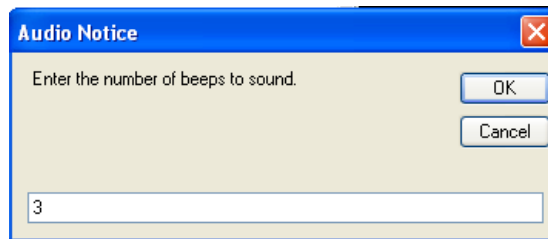

**Message** – Program Builder allows the user to create up to 10 messages that can be displayed during program execution. The messages are saved to a comment table, then can be displayed by passing the index of the message to display. For example, the code segment to the right causes the message stored at message

### Program Listing

```
Home(1)
Port(1, 3)
Fill(1)
Message(2)
```

**Comments Table**

	Comment
Note 1	The system is about to dispense to the outlet port. Make sure the reactor is stirring.
Note 2	An over-temperature condition was encountered. Reset the cooling system.
 Note 3	Reaction is Complete!!
Note 4	
Note 5	
Note 6	
Note 7	
Note 8	
Note 9	
Note 10	

**Save Comments**

location #2 to display. This is a convenient way to pass program critical messages to a user. While a message is displayed, the program pauses until the user acknowledges the message by clicking the ‘OK’ button that’s displayed with the message.

Messages can be added, edited or deleted by selecting the menu command “Display Comment Table” in the Programs menu tab. When done entering messages, click the Save Comments button.

**Parallel Dispense** – This command handles a special case for multi-position pumps when it's desirable for two different dispense operations to occur simultaneously.

Most commands in the program file occur sequentially, and a command later in the list does not execute until the one preceding it completes. The Parallel Dispense command allows the pumps to dispense different volumes in parallel rather than sequentially. For example, in the short program segment shown to the right, pump 1 will dispense 5ml while pump 2 dispenses 2.5ml in parallel with one another. Earlier in the program, the speed of pump 1 was set to 20ml/min and the speed of pump 2 was set to 10ml/min, so even though the two pumps are delivering different volumes, because they are at different rates, they will complete the dispense at the same time. When selected from the command list, Parallel Dispense prompts the user for the volume to dispense from each active syringe pump. The command WaitForReady(0) is added by the program automatically to ensure that the program waits until both pumps have completed the dispense before proceeding.

### Program Listing

```
Speed(0, 50)
Fill(0)
Speed(1, 20)
Speed(2, 10)
Port(0, 2)
Parallel Dispense(1, 5.0000)
Parallel Dispense(2, 2.5000)
WaitForReady(0)
```

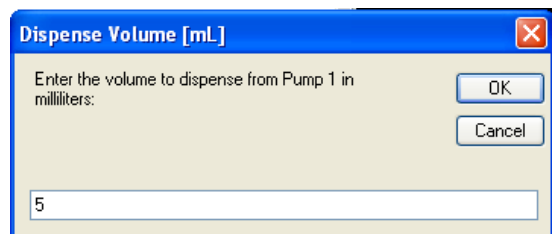

Dispense Volume [mL]

Enter the volume to dispense from Pump 1 in milliliters:

5

OK Cancel

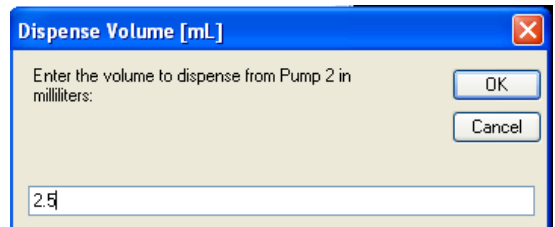

Dispense Volume [mL]

Enter the volume to dispense from Pump 2 in milliliters:

2.5

OK Cancel

**Parallel Withdrawal** - This command handles a special case for multi-position pumps when it's desirable for two different withdrawal operations to occur simultaneously.

Most commands in the program file occur sequentially, and a command later in the list does not execute until the one preceding it completes. The Parallel Withdrawal command allows the pumps to withdraw different volumes in parallel rather than sequentially. For example, in the short program segment shown to the right, pump 1 will withdraw 7.5ml while pump 2 withdraws 1.25ml in parallel with one another. Earlier in the program, the speed of pump 1 was set to 20ml/min and the speed of pump 2 was set to 10ml/min, just to show that the pump speeds do not need to be the same. When selected from the command list, Parallel Withdrawal prompts the user for the volume to withdraw from each active syringe pump. The command WaitForReady(0) is added by the program automatically to ensure that the program waits until both pumps have completed the dispense before proceeding.

### Program Listing

```
Speed(0, 50)
Fill(0)
Speed(1, 20)
Speed(2, 10)
Port(0, 2)
Parallel Withdraw(1, 7.5000)
Parallel Withdraw(2, 1.2500)
WaitForReady(0)
```

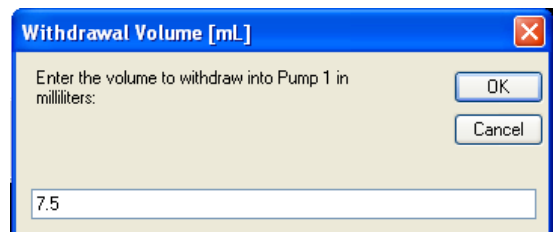

Withdrawal Volume [mL]

Enter the volume to withdraw into Pump 1 in milliliters:

7.5

OK Cancel

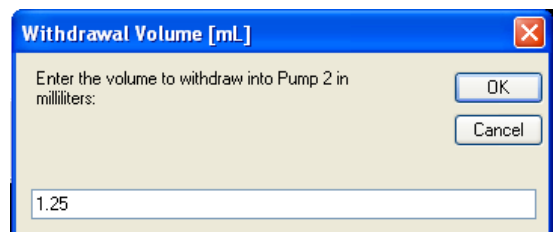

Withdrawal Volume [mL]

Enter the volume to withdraw into Pump 2 in milliliters:

1.25

OK Cancel

**Digital Output** – If the pump is equipped with the optional IO package, this command sets the state, either On or Off, of the specified digital output. When selected, the program prompts the user to select the output channel (1-3), then once the channel is selected to specify its state (On or Off).

For dual position pumps, each pump can have its own output bank consisting of three outputs. If the pump is configured with 3 outputs, these outputs are operated by Pump 1, if it has 6 outputs, then the first three outputs are operated by Pump 1, and the second three are operated by Pump 2. Make sure that the radio button for the correct pump is checked before selecting this command.

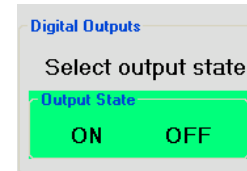
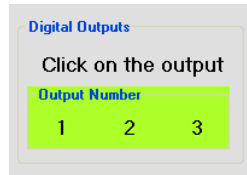

**If\_Input(IsHigh)** – For units equipped with the optional IO package, this command examines the state of the specified input (1-3), and if the state is High (i.e., >3 Vdc) executes the statements that appear between the If\_Input(IsHigh) statement and the EndIf() statement. If the input is low (i.e., <1 Vdc), then the statements in the If block are skipped.

When the If\_Input(IsHigh) statement is selected, the program prompts the user for the digital input to examine (Range 1-3). After selecting the input to examine, the software opens the If statement. Add any syringe pump commands that should be executed if the selected input is high. When done, click the EndIf() command in the red box to close the loop. Note that another If statement cannot be nested inside of an open If statement.

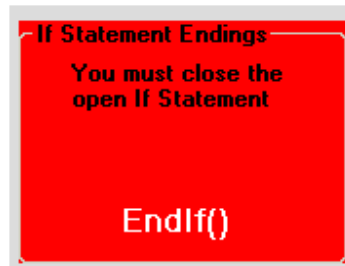
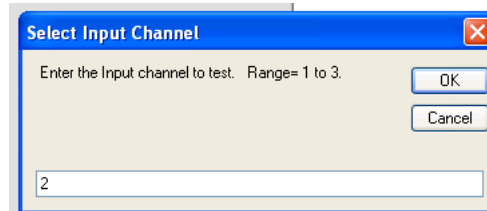

**If\_Input(IsLow)** – For units equipped with the optional IO package, this command examines the state of the specified input (1-3), and if the state is Low (i.e., <1 Vdc) executes the statements that appear between the If\_Input(IsLow) statement and the EndIf() statement. If the input is high (i.e., >3 Vdc), then the statements in the If block are skipped.

When the If\_Input(IsLow) statement is selected, the program prompts the user for the digital input to examine (Range 1-3). After selecting the input to examine, the software opens the If statement. Add any syringe pump commands that should be executed if the selected input is low. When done, click the EndIf() command in the red box to close the loop. Note that another If statement cannot be nested inside of an open If statement.

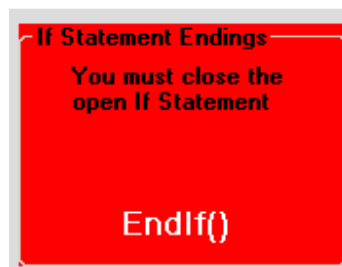
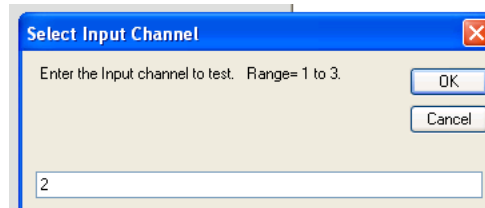

**120Vac Outlet** – For pumps with the optional 120Vac outlet installed, selecting this command provides the option of turning the Outlet On or Off. When the 120Vac Outlet command is clicked, a new screen appears that prompts the user to select the outlet state, either On or Off. Click on the selected state.

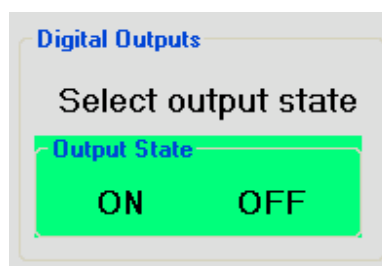

**Open Loop** – Clicking on the Open Loop button, opens a programming element that allows the user to enter a series of commands that appear between the Open Loop and a Close Loop command. Any commands that appear between the Open and Close Loop commands are executed for the number of loop passes entered by the user. For example, clicking on the Open Loop button brings up an input box that prompts the user to enter the number of times to execute the statements in the loop. Once the number of loop passes is entered, the commands inside the loop are added. After adding the last command to run inside the loop, the loop is closed by clicking on the Close Loop button.

The nature of Loops (more commonly known as Do Loops) is beyond the scope of this syringe pump manual to fully cover, but several examples are presented for instruction.

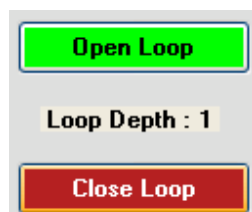
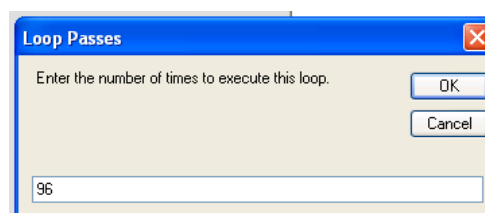
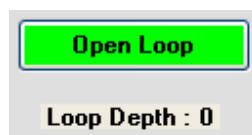

Example 1 – Filling a microtiter plate.

Note, line numbers normally don't appear in pump programs, they were added only for illustration purposes.

This is a line-by-line execution of the program.

Line 1 – The pump positions the valve to Port 2.

Line 2 – The pump fills the syringe.

Line 3 – The pump moves to Port 1 (connected to the outlet line).

Line 4 – The Loop() command is not executable, but it does load the number of loop repetitions, in this case 96.

Line 5 – The pump dispenses 20 microliters

Line 6 – The program delays 0.4 seconds (to give the user time to move the outlet probe to the next well in the titer plate).

Line 7 – The program examines how many times it has executed the loop (Lines 5 & 6), if it is less than 96 times, then the program jumps back to line 5, if this is the 96th pass, the program jumps to line 8.

Line 8 – The pump moves the valve to Position 2.

Line 9 – The pump returns the remaining reagent to the reagent reservoir.

```
1. Port(1, 2)
2. Fill(1)
3. Port(1, 1)
4.   Loop(96)
5.     Dispense(1, 0.0200)
6.     Delay_Seconds(1, 0.4)
7.   Close_Loop(1)
8. Port(1, 2)
9. Home(1)
```

What should be noticed in this program is that the user must make sure that the syringe always has enough reagent in the syringe to make the required dispense.

Example 2 – Filling a titer plate with automatic refills

In this example, the pump is fitted with a 10ml syringe, the reagent reservoir is on pump port 2, and the dispensing tip is on pump port 1. This program will allow Loops to be nested 3 deep, in this case, the loop is nested 2 deep.

The program enters the first loop on line 2, this loop consists of all the statements from lines 2 to 10. The statements in the outer loop will be executed 12 times. On lines 3-5 the pump fills with reagents and positions the valve to the dispense port. The nested loop consists of all the statements from lines 6 to 9. The statements on lines 7 & 8 will be executed 8 times before exiting the nested loop. When the nested loop is entered on line 6, the syringe has 10ml of fluid. After executing the nested loop 8 times, the loop exits on line 9. When line 10 is hit, the program jumps back to line 3, where the syringe refills with reagents, then positions itself back to the dispense port. It then reenters the nested loop. The process continues until the outer loop executes 12 times. At the end of this simple program, the pump has added 1ml to each well of a 96 well titer plate (96 ml) using a 10 ml syringe.

```
1. Home(1)
2.   Loop(12)
3.     Port(1, 2)
4.     Fill(1)
5.     Port(1, 1)
6.       Loop(8)
7.         Dispense(1, 1.0000)
8.         Delay_Seconds(1, 0.4)
9.       Close_Loop(2)
10.    Close_Loop(1)
11.  Port(1, 2)
12. Home(1)
```

### Rules for Ifs and Loops

Loops can be nested 3 deep.

A single If can appear in a Loop, but then no other If's or Loops can be nested until the If is closed.

A single Loop can appear in an If, but no other If's or Loops can appear until the Loop is closed.

## Temperature Controller Functions

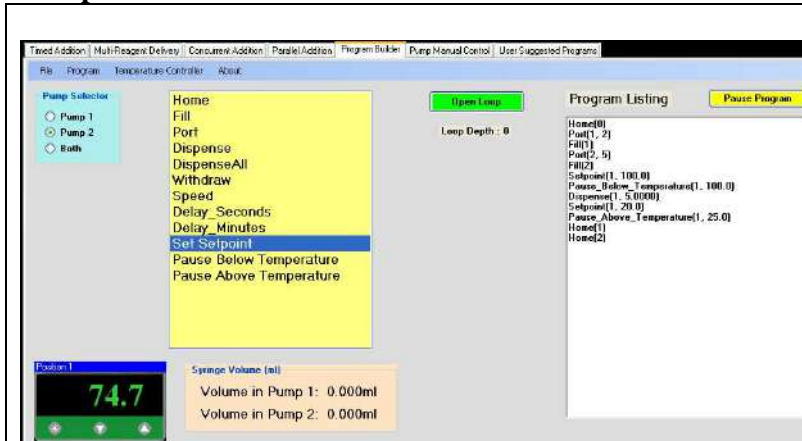

The function of a J-KEM temperature controller can be added to the form. This allows the user to control the temperature of an attached reaction, or control the addition of reagents as a function of reaction temperature. To add the controller to the form, connect a USB enabled J-KEM controller to any of the USB ports on the PC running the syringe pump. Turn on power to the controller, then select 'Find Controller' from the Temperature Controller menu.

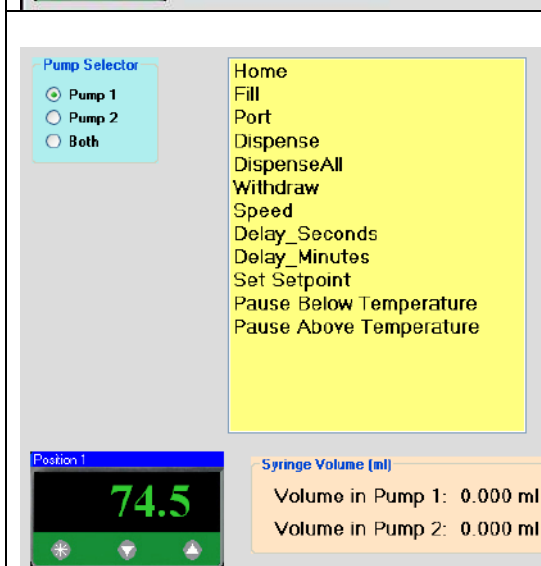

When the controller is added to the form, three new commands are added to the Command Selection Box. The function of these commands are:

**Set Setpoint** – Enters a new setpoint temperature (i.e., desired reaction temperature) into the temperature controller.

**Pause Below Temperature** – When this command is encountered during a syringe pump program, the program pauses or continues based on the current reaction temperature. If the user enters a “Pause Below Temperature” of 50° C, the progress of the syringe pump program will pause as long as the sensed temperature is below 50° C. When the sensed temperature reaches 50° C, the pump program continues.

**Pause Above Temperature** – When this command is encountered during a syringe pump program, the program pauses or continues based on the current reaction temperature. If the user enters a “Pause Above Temperature” of 40° C, the progress of the syringe pump program will pause as long as the sensed temperature is above 40° C. When the sensed temperature falls to 40° C, the pump program continues.

```
Home(0)
Port(1, 2)
Fill(1)
Port(2, 5)
Fill(2)
Setpoint(1, 100.0)
Pause_Below_Temperature(1, 100.0)
Dispense(1, 5.0000)
Setpoint(1, 20.0)
Pause_Above_Temperature(1, 25.0)
Home(1)
Home(2)
```

## Editing Syringe Pump Programs

### Program Listing

```
Home(1)
Port(1, 2)
Fill(1)
Speed(1, 5)
Dispense(1, 0.5000)
```





### Program Listing

```
Home(1)
Port(1, 2)
Fill(1)
Speed(1, 5)
Port(1, 3)
Dispense(1, 0.5000)
```



### Program Listing

```
Home(1)
Port(1, 2)
Fill(1)
Speed(1, 5)
Port(1, 4)
Dispense(1, 0.5000)
```

Position cursor  
here when done

### Program Listing

```
Home(1)
Port(1, 2)
Fill(1)
Port(1, 4)
Dispense(1, 0.5000)
```



Speed command  
deleted

As long as a program is under construction, it is simply a text file. As such, it can be edited, statements inserted or deleted, or entire sections of code added. This section describes the editing controls.

**Inserting a Single Statement** – While a program is under construction, statements that were inadvertently forgotten can be added at the point in the program they need to appear. For example, if a Port statement should have been entered between the Speed and Dispense statements, the Port command can be added by positioning the text cursor at the end of the end of the Speed command (immediately after the right most parenthesis), then click on the Port command

**Editing a Statement** – The text of any statement can be edited. For example, if the pump should have been directed to port 4, rather than port 3 in the newly entered command, the user can simply delete the '3' and replace it with '4'. When you are done editing, you must position the cursor on the first line after the last program statement, so that new commands are entered at the end of the program.

**Deleting a Statement** – Any line in the program can be deleted simply by selecting the line in the program window and deleting it. You must delete the entire statement and remove any blank lines. Once the statement is deleted, you must position the cursor on the first line after the last program statement, so that new commands are entered at the end of the program.

### Program Listing

```
Home(1)
Port(1, 2)
Fill(1)
Speed(1, 5)
Port(1, 4)
Dispense(1, 0.5000)
Dispense(1, 0.2000)
Home(1)
```

### Program Listing

```
Home(1)
Port(1, 2)
Fill(1)
Speed(1, 5)
Port(1, 4) ← Add statement after
Dispense(1, 0.5000) this line.
Dispense(1, 0.2000)
Home(1)
```

### Program Listing

```
Home(1)
Port(1, 2)
Fill(1)
Speed(1, 5)
Port(1, 4)
Home(1)
Home(1)
Home(1)
Home(1)
Dispense(1, 0.5000)
Dispense(1, 0.2000)
Home(1)
```

These statements were added

**Saving a Code Block** – After a program is created, it might be useful to save sections of the program that perform a useful task. Then when new programs are created, rather than having to enter the individual statements that perform the task, the entire block of statements can be added at one time. To save a block of statements, highlight the desired statements in the Program Listing Box, then select Save Code Block from the Program menu. You will be prompted to enter a name for the code.

**Inserting a Code Block** – Code blocks previously saved can be added to a program under construction. Position the cursor at the end of the line where the code block should be inserted after (in this case at the end of the Port(1, 4) command) and then select Insert Code Block from the Program menu. In this case, the code block (previously saved) that was inserted are the four Home(1) commands.

First character MUST be a single quote mark.

```
Program Listing
Home(1)
Port(1, 2) 'Port 2 has the amine on it
Fill(1)
Speed(1, 5) 'Set the speed to a fast rate
Port(1, 4)
Dispense(1, 0.5000)
'Here you should do two dispenses
Dispense(1, 0.2000)
Home(1)
```

Blank lines with a single quote mark are OK

Comment lines can appear on a line by themselves, but the line MUST start with a single quote mark

**Adding Comment Statements** – Comments statements, or non-executed text statements, can be added at any point in a program. Comment statements are useful to document what the program does.

**Saving a Program** – Once a program is created, it can be saved to disk by selecting Save Program from the Program menu. Once selected, the user is prompted for a file name to save the program to.

**Recalling a Program** – A program previously saved to disk can be recalled by selecting Recall Program from the Program menu.

**Deleting a Program** – A program previously saved to disk can be deleted by selecting Delete Program from the Program menu, then selecting the program to delete.

### **Menu Commands**

These options in the program menu have the following effects.

**Start** – The Start command causes the syringe pump to begin executing the program script as it appears in the Program Listing window at the first command.

**Pause Program** - A running program can be paused by selecting this command. The currently active command is completed, then the program pauses.

**Resume Program** – A paused program is resumed by selecting this command.

**Abort Program** – Causes a running program to terminate after completing the currently running command.

## Remote Mode

In Remote mode, a remote PC, for example, a PC that's part of a robotic system or other larger piece of equipment, sends serial commands to the PC controller operating the syringe pump. The commands are executed one-by-one as they are received by the PC physically connected to the syringe pump.

Hardware connections - Contact J-KEM if you need additional assistance.

RS232- to RS232 serial connection using a null modem cable.

Baud – 9600, 8 data bits, 1 stop bit, no parity, no hardware or software handshaking.

Commands are terminated with a carriage return <Cr>, 0x0D (don't include a line feed).

Commands are case insensitive.

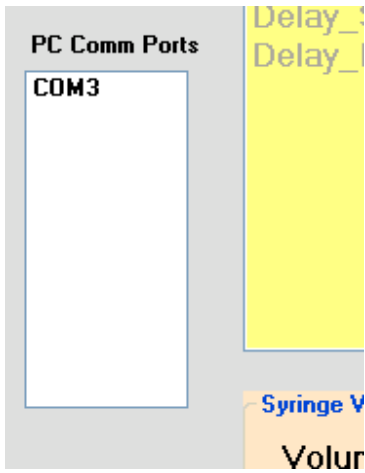
 <p>The screenshot shows a window titled 'PC Comm Ports' with a list containing 'COM3'. To the right, there is a yellow 'Delay_' control and a 'Syringe V' control with a 'Volur' label below it.</p>	<p>To activate remote mode, select Run by Remote Serial Command from the Program menu. After selecting this option, a list of available comm ports appears, click on the comm port used for communications on the PC attached to the syringe pump. At this point, the syringe pump PC is ready to receive commands.</p> <p>Serial Protocol. The remote PC initiates all communications by sending a syringe pump command. The command is executed and the syringe pump replies after the sent command is completed. Do not send a new command until the pump replies to the current command. Note, monitoring for the reply from the syringe pump is the only reliable way to know when it's safe to send the next command.</p> <p>The reply of a correctly formatted command is the command itself with the characters 'OK' appended to the end. All commands are terminated by carriage return, of 0x0D.</p>
<p>Example: Remote PC sends "HOME(1)", the reply is "HOME(1)OK&lt;Cr&gt;."</p> <p>If an incorrectly formatted command is send, the pump replies with the command sent and then appends the characters 'BAD' to the end.</p> <p>Example; Remote PC sends "HOOME(1), the reply is "HOOME(1)BAD&lt;Cr&gt;"</p> <p>If an improper command causes an unrecognized error, the pumps reply is simply "BAD&lt;Cr&gt;."</p> <p>You must monitor for the pumps reply and not send a new command until the current command is complete, because sending a command before the current command completes may cause the pump program to hang.</p> <p>Addressing – For a single pump system, the address of the pump is '1'. For a dual pump system, the address of the first pump is '1', and the second pump is '2'. An address of '0' can be used at any time, which globally addresses all pumps in the system.</p>	

Command	Comments
<b>Home(address)</b>	Dispenses the entire volume of the syringe and resets all counters to 0.
<b>Dispense(address, volume)</b> <i>volume</i> is the volume of fluid to dispense as a floating point number in units of milliliters.	Dispenses the requested volume. If the requested volume exceeds the volume in the syringe, the entire content of the syringe is dispensed and the command terminates.
<b>Dispenseall(address, volume, port)</b> <i>volume</i> is the volume of fluid to dispense as a floating point number in units of milliliters. <i>port</i> is the distribution valve port to refill from (the port the reagent is on). The port that the pump is on when the command starts, is the dispense port.	Dispenses the entire volume requested, independent of the size of the syringe, or the volume currently in the syringe. This command only operates on a single syringe pump. For dual syringe pump systems, a continuous delivery of solvent using both syringes can be run using the command <code>Timeddelivery()</code> below.
<b>SlowDispense(address, volume, rate)</b> <i>volume</i> is the volume of fluid to dispense as a floating point number in units of milliliters. <i>rate</i> is the dispense rate in units of ml/min as a floating point number.	Dispenses the requested volume at the specified rate. If the requested volume exceeds the volume in the syringe, the entire content of the syringe is dispensed and the command terminates. The rate specified must be less than the 'Continuous Delivery Rate' for the syringe size in use or the command will not execute.
<b>Fill(address)</b>	Fills the syringe to its maximum volume.
<b>Withdraw(address, volume)</b> <i>volume</i> is the volume of fluid to dispense as a floating point number in units of milliliters.	Withdraws the requested volume, but does not exceed the filling the syringe to its maximum volume.
<b>SlowWithdrawal(address, volume, rate)</b> <i>volume</i> is the volume of fluid to withdraw as a floating point number in units of milliliters. <i>rate</i> is the withdrawal rate in units of ml/min as a floating point number.	Withdraws the requested volume at the specified rate. If the requested volume exceeds the volume in the syringe, the syringe fills, then the command terminates. The rate specified must be less than the 'Continuous Delivery Rate' for the syringe size in use or the command will not execute.
<b>Port(address, port)</b> <i>port</i> is the distribution valve port to move to.	Moves the distribution valve to the requested position.
<b>Speed(address, speed)</b> <i>speed</i> in units of ml/min.	Sets the withdrawal and dispense speed to the specified volume, but does not exceed the minimum or maximum speed of the syringe.
<b>Timeddelivery(address, volume, rate, inletport)</b> <i>address</i> is the pump address to use for the delivery. In a dual pump system, if the address is 0, both pumps are used for a continuous delivery of reagent. <i>volume</i> is the volume of fluid to dispense as a floating point number in units of milliliters. <i>rate</i> is the reagent delivery rate in units of ml/min. <i>inletport</i> is the distribution valve port that the reagent is attached to, i.e., the port the syringes refill from. The port that reagent is delivered to is the port the pumps are set to when the command is issued.	This command is used to run the timed delivery program. For single pump systems, or dual pump systems when you only want to use one pump, this command is equivalent to the <code>Dispenseall()</code> command.  For dual pump systems, this command allows the user to use both pumps to dispense reagent in an unbroken stream. This command is equivalent to the Timed Delivery program.
<b>For systems with the optional IO package</b> <b>Input(line)</b>  <i>line</i> is the input or output line to test or set (1-3). <i>state</i> of the output. Must be either "On" or "Off".  <b>Output(line, state)</b>	Queries the state of the specified digital input. This command is unique from all other commands in that it must return a value to the query. If the input has a logical high state the returned reply is "Input(address)1OK", the '1' indicates the logical high state. If the input has a logical low state the returned reply is "Input(address)0OK", the '0' indicates the logical high state.  Sets the state of the specified output to the specified value.
For systems with the optional 120 VAC output <b>120V_Outlet(state)</b>  <i>state</i> of the outlet. Either "On" or "Off"	Sets the state of the 120Vac to the specified value.

## Manual Control

This tab provides a way to manually adjust the syringe pump and distribution valves state.

Pump 1 : V6 Syringe Size : 10 ml Port Positions : 4	Pump 2 : V6 Syringe Size : 10 ml Port Positions : 4	Pump 3 : None	Pump 4 : None
---	---	---------------	---------------

At the bottom of the screen is a window that shows the current configuration of the syringe pump system. The information shown on this

panel must be correct for your syringe pump system. If you change the syringe size or the distribution valve on the pump, you must edit the syringe pump configuration to reflect these changes. For instructions on how to change the system's pump configuration, see the section titled 'Installing a Syringe or Distribution Valve.'

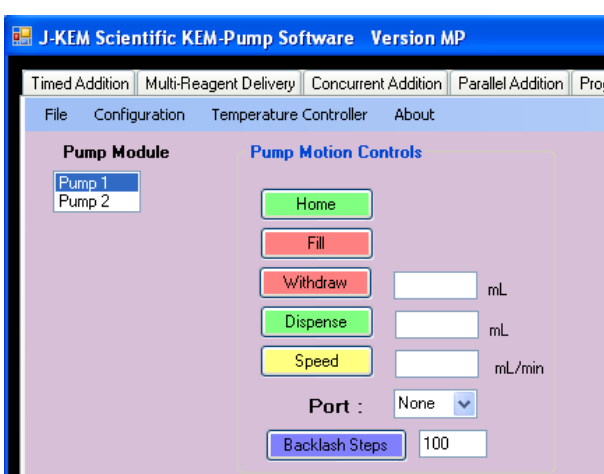

**Pump Module** – Select the pump module to operate on.

**Home** – Clicking this button causes the syringe to empty its content through the port the distribution valve is currently set to.

**Fill** – Clicking this button fills the syringe from port currently selected on the distribution valve.

**Withdraw** – Clicking this button causes the pump to withdraw the volume entered into the associated text box. The pump will not withdraw more than the volume remaining to fill the syringe.

**Dispense** – Clicking this button causes the pump to dispense the volume entered into the associated text box. The pump will not dispense more than the volume remaining in the syringe.

**Speed** – Clicking this button sets the pump to the speed entered into the associated text box. This speed is used for both withdrawals and dispenses.

**Port** – Selects the port the distribution valve is set to.

**Backlash Steps** – When the syringe performs an aspirate (withdrawal) motion, it normally withdraws a certain number of extra steps and then reverses direction and dispenses the extra steps. This acts to re-tension the pump in preparation for the next dispense motion. These extra steps are called backlash steps. The default value is 100, but can be set to any value from 0 to 1000.

**User Output 1, 2, and 3** – The syringe pump can optionally be equipped with three User addressable output ports capable of sinking 170 mA each at input voltages up to 40 Vdc. These controls set the state of the outputs.

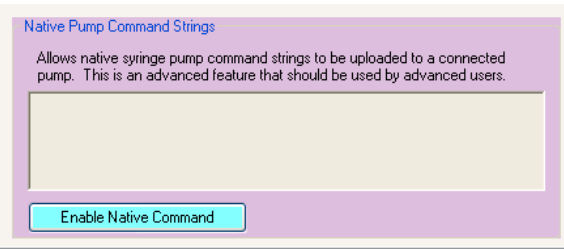
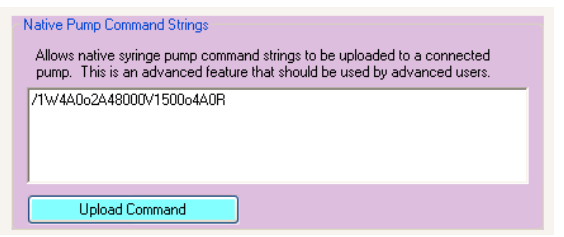
	<p>At the most basic level of operation, the pump communicates using its' native command language. KEM-Rx software is designed to insulate the user from the complexity of the native command language, but for some very advanced users being able to write a command string directly to the pump is a valuable feature. The structure of the native command language is well beyond the scope of this user manual.</p>
	<p>To enable the command input box, click on the button titled Enable Native Command. Once enabled, the user can enter the desired command string, then click the Upload Command button. Include the terminating Run command 'R' but not do not include the terminating carriage return '0x0D'</p>

## Input / Output Options

This screen appears as one of the program tabs if any of the optional Input / Output packages are installed on the pump. Depending on which of the two optional features listed below, are installed, different portions of this screen will be enabled.

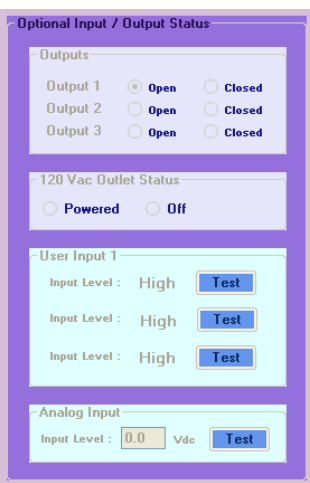
	<p><b>Optional Input / Output Status –</b>  This group box is enabled if the I/O Package option is installed. This package provides three TTL level digital inputs, three 24Vdc high current outputs, and one 0-5Vdc analog input.</p> <p><b>120Vac Outlet –</b> This group box is enabled if the programmable 120 Vac outlet option is installed. This option provides a 120 Vac outlet that can be used to turn On (or Off) other pieces of equipment under program control. If both the IO option and the 120Vac outlet are installed, the 120Vac outlet uses the User Output #1, which will be unavailable for other uses.</p>
---	--

The User IO feature provides three high current outputs and three TTL level digital inputs.

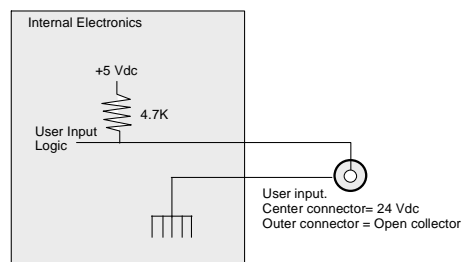
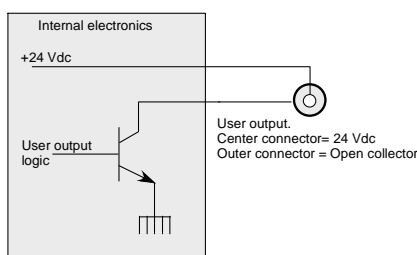

The connectors for the Input / Output ports are on the side of the syringe pump.

**User Outputs** - The outputs are open collector and can sink 170 mA each at 24 Vdc. Wiring of the outputs is shown in the drawing above.

The KEM-Rx programmers' manual contains detailed information on the functions controlling user output. The relevant function is:

`Pump.UserOutput ( )`

**User Inputs** - The digital inputs measure TTL logic levels (0-5 Vdc) and have 4.7 K pull-up resistors. Logical 0 is any voltage  $\leq 1$  Vdc. Logical 1 is any voltage  $\geq 3.5$  Vdc.

The analog input returns the voltage applied to the input in the range of 0 to 5.0 Vdc.

Do not apply voltages outside of the range of 0 to 5 Vdc or damage may result to the pump.

The KEM-Rx programmers manual contains detailed information on the functions controlling user inputs. The relevant functions are:

`Pump.UserInput ( )`  
`Pump.AnalogInput ( )`

## 120 Vac Power Outlet Option

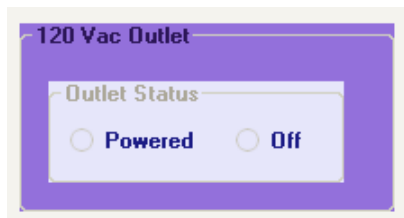

**The 120 Outlet Option** – This option provides a 120 Vac outlet with 10 amps of outlet current that is under program control. The receptacle is located on the back of the syringe pump.

When present, the state of the 120 Vac receptacle is controlled by user output #1. The command to turn On the receptacle is:

`Pump.UserOutput(1, SyringePumpDef.PumpPowerState.PowerOn)`

The command to turn Off the receptacle is:

`Pump.UserOutput(1, SyringePumpDef.PumpPowerState.PowerOff)`



The function of a J-KEM temperature controller can be added to the software interface of the syringe pump. This provides a single interface for processes requiring temperature control during the pumping sequence. For a full description of the temperature control function, see the section titled "Temperature Controller Functionality".

Highlights include:

- On-screen temperature display and control.
- 16-Step temperature ramp.
- **An optional software add-on allows the rate of reagent addition to be controlled as a function of reaction temperature.**

## User Suggested Programs

On occasion, users request custom programs that J-KEM thinks might be useful to other users. On the User Suggested Programs tab are those programs.



The function of a J-KEM temperature controller can be added to the software interface of the syringe pump. This provides a single interface for processes requiring temperature control during the pumping sequence. For a full description of the temperature control function, see the section titled “Temperature Controller Functionality”.

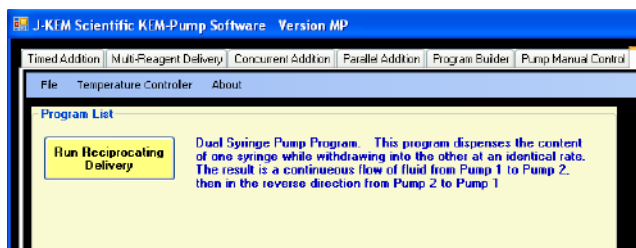

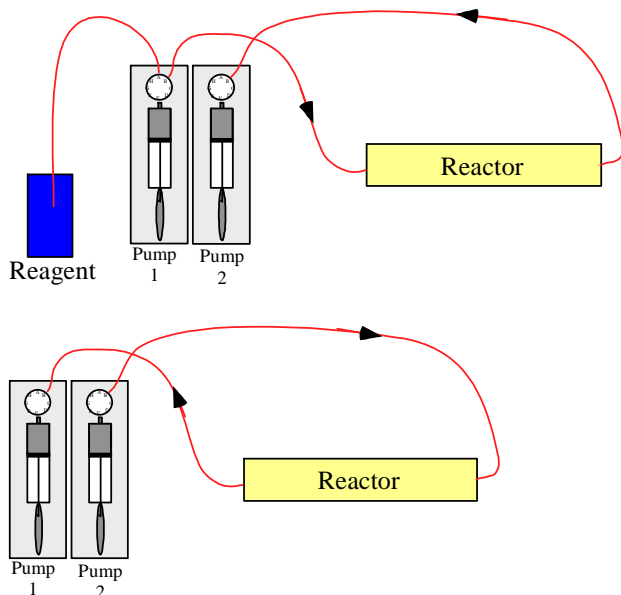

The Precipitating Delivery program is only available to dual syringe pump systems. This program uses one pump to add reagent/solvent to one port on a closed system reactor while simultaneously withdrawing reagent/solvent from a second port on a closed system reactor. The net effect is that the fluids in the reactor remain in continuous motion in a back-and-forth flow pattern.

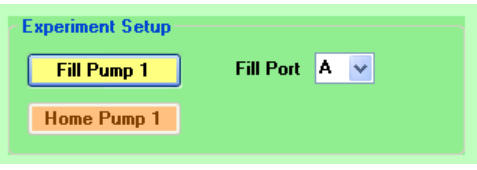
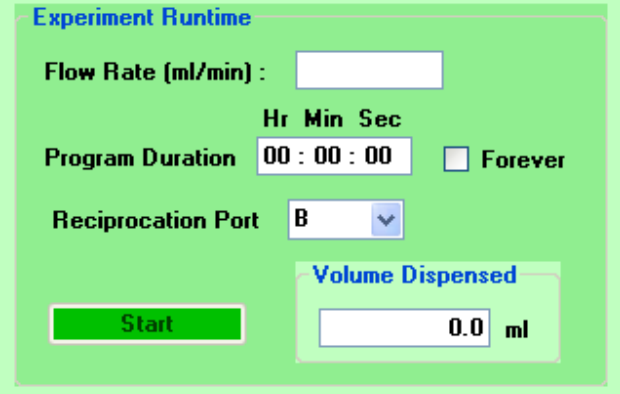
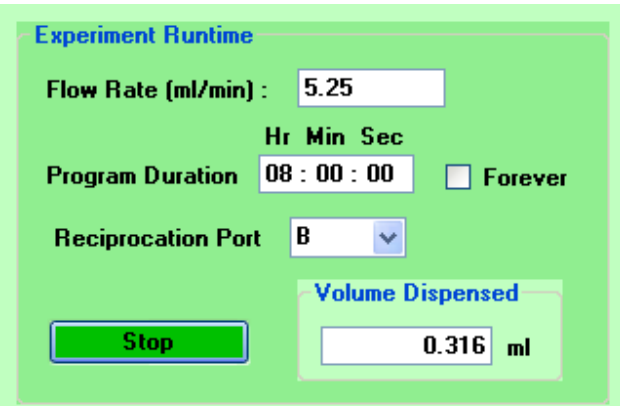

For the first segment of the program, Pump 1 delivers fluid into one end of the reactor while Pump 2 withdraws from the other at the same rate.

When Pump 1 completes its delivery, Pump 2 starts to deliver and Pump 1 starts to fill, thus reversing the flow through the reactor.

	<p>To make the experiments controls visible, click the Run Precipitating Delivery button.</p> <p><b>Experiment Setup</b> – The Experiment Setup box provides the option of initially filling syringe 1 with reagent/solvent from a port, other than the port connected to the reactor. To fill the syringe, select the port on the distribution valve to connect to, then click the Fill Pump 1 button. The experiment requires that pump 1 is initially filled with reagent/solvent. After the syringe fills, you have the option of emptying the syringe or starting the program. The option to empty and fill the syringe provides the user the option of purging air from the system prior to beginning the experiment. You can select any port to Home and Fill on.</p>
	<p>To begin the experiment, enter the desired flow rate into the text box provided, then enter the desired run time in the Program Duration box. To run the program continuously, until being manually terminated, check the 'Forever' check box.</p> <p>Select the distribution valve port that the reactor's inlet and outlet are connected to on Pumps 1 &amp; 2 (must be the same port), then click the start button.</p>
	<p>While an experiment is running, the volume dispensed text box continuously updates. The Flow rate can be changed at any time, but the change does not take effect until the pumps reverse direction.</p> <p>While an experiment is running, what used to be the Start button changes to "Stop". To manually abort a running experiment, click the Stop button.</p>
	<p>When the Stop button is clicked, a new box appears. This box provides the option of emptying the contents of both syringes on the selected distribution valve port.</p>

# Temperature Control Functionality

	<p>Each experiment has the menu item <i>Temperature Controller</i> which adds a software interface to a J-KEM Scientific temperature controller on the experiment tab page.. The interface allows real-time monitoring of reaction temperatures and remote control of the meters heating process.</p>
---	---

## Hardware Setup

A J-KEM temperature controller with a USB interface is required. Connect a USB cord between the controller and a USB port on the PC operating the syringe pump. Set up the experiment involving the temperature controller and heater as you would normally.

## Software Operation

To view the controller on the syringe pump forms, the pump must be powered. The menu options related to temperature control are:

**Discover Controller** - Searches the USB ports on the PC. The first controller found on the USB bus causes an image of a digital meter to appear on the screen. If the model of controller connected to the PC has multiple digital meters, like the dual channel Gemini, or Apollo, only the first channel of the controller is connected to the syringe pump software.

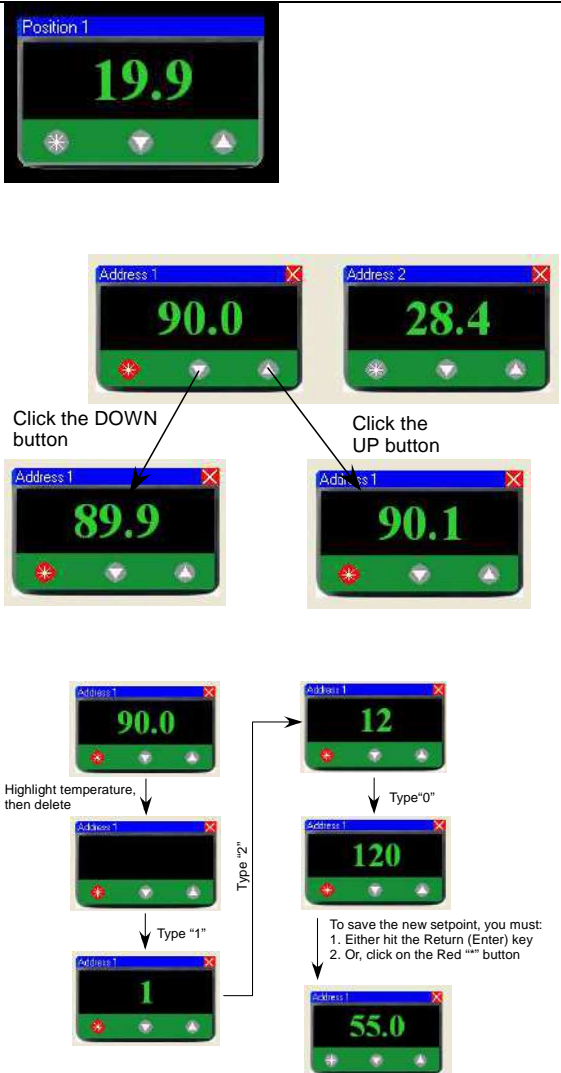

Click the DOWN button

Click the UP button

Highlight temperature, then delete

Type "1"

Type "2"

Type "0"

To save the new setpoint, you must:  
1. Either hit the Return (Enter) key  
2. Or, click on the Red "\*" button

## Entering a Temperature Setpoint

The normal state of the meter is to show the current temperature of the attached sensor.

There are 3 ways to enter a new setpoint into the meter.

- 1) A new setpoint can be entered into the physical meter itself without the use of software even when the controller is connected to the PC. A setpoint is physically entered by pressing the physical "\*" button on the face of the digital meter, then pressing the Up or Down arrow keys on the meter.
- 2) A new setpoint can be entered using the software by clicking on the "\*" button on the face of the meter as it appears on the PC screen. When in setpoint edit mode, the "\*" button turns red and the current meter setpoint appears in the display. While in setpoint edit mode, clicking on the Down button will decrease and clicking on the Up button will increase the setpoint. When the desired setpoint is showing in the display, clicking the red "\*" button will upload the newly entered setpoint to the digital meter, which will then return to displaying the current process temperature.
- 3) Another method for entering a new setpoint is to click the "\*" button, placing the meter in setpoint edit mode (the "\*" turns red), then highlighting the current setpoint, displayed on the meters face, and typing in the new setpoint. When the desired setpoint is entered (i.e., typed) into the display, clicking the red "\*" button will upload the new setpoint to the digital meter.

## Installing a Syringe or Distribution Valve

Replacing a syringe and/or distribution valve is a simple task which takes about one minute, but if performed improperly will result in leaks or damage to the pump.

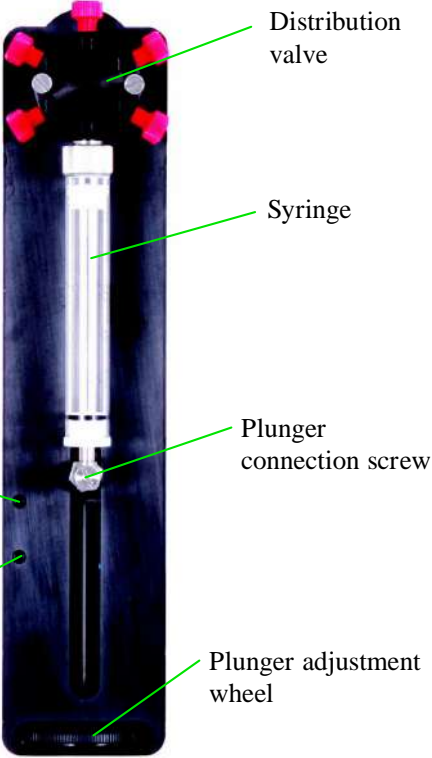
 <p>The diagram shows a syringe pump assembly. At the top is a distribution valve with two red ports. Below it is a syringe. A plunger connection screw is attached to the syringe plunger. On the left side of the pump body, there are three buttons: Home, Initialize, and a small unlabeled button. At the bottom is a plunger adjustment wheel.</p>	<h3>Syringe and Valve Removal</h3> <p>Step 1 Turn on power to the syringe pump, but do not start the KEM-Rx software. Using something with a long point (paperclip or pencil) press the recessed Initialize button on the left face of the pump to place the pump in a manual operation mode.</p> <p>Step 2 Using your finger, turn the Plunger adjustment wheel until the plunger of the syringe is about ½ inch below the top of the syringe.</p> <p>Step 3 Remove the plunger connection screw (Cat # SPSS) attaching the syringe plunger to the syringe pump drive mechanism.</p> <p>Step 4 Using only your hands (no tools), unscrew the syringe from the distribution valve body.</p> <p>Step 5 If the distribution valve is being replaced, remove all of the tube fittings from the valve, then remove the two screws holding the valve to the face of the syringe pump (Cat # SPCC). The valve will pull straight off the pump now.</p>
<h3>Syringe and Valve Replacement</h3> <p>Step 1 If the valve was removed from the pump, place the new valve on the pump and push gently until the back side of the valve is pressed flush against the face of the pump. Now replace the two silver screws that attach the valve to the pump. Reconnect any fluid fittings that were removed.</p> <p>Step 2 Screw the syringe back into the valve using only your hands (no tools).</p> <p>Step 3 Manually position the plunger rod so that the hole for the plunger connection screw aligns with the connector on the back of the pump. Insert the plunger connect screws through the plunger rod hole and into the connector on the body of the pump. <b>It is critically important</b> that this screw be replaced properly. Follow this procedure <b>exactly</b>.</p> <ol style="list-style-type: none"><li>Insert the screw until it bottoms out in the connector on the body of the pump.</li><li>Using a screwdriver, press firmly on the screw and rotate it slowly counterclockwise until you fell a slight <i>click</i> (this aligns the threads of the screw with the threads of the connector body).</li><li>Now tighten the screw into the connector until it's firmly set.</li></ol> <p>Step 4 Press the initialize button (the pump must have power applied) and the syringe plunger will move slightly. Using the plunger adjustment wheel, manually move the plunger until it bottoms out leaving no volume in the syringe.</p> <p>Step 5 Press the Home button. The plunger should move down, then return to top of the syringe.</p> <p>Step 6 You must now configure the software for the new hardware.</p>	

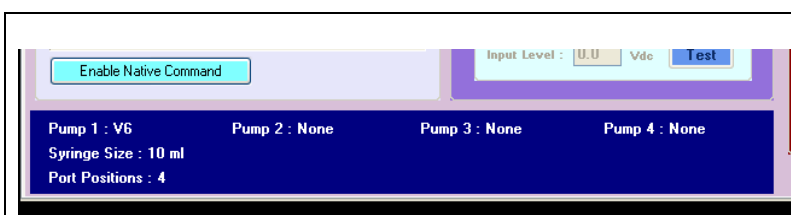

1) Start KEM-Rx and select the tab titled Pump Manual Control. A window at the bottom of the screen shows the last entered pump configuration. If the configuration is no longer correct and must be edited, select Pump Configuration from the Configuration menu.

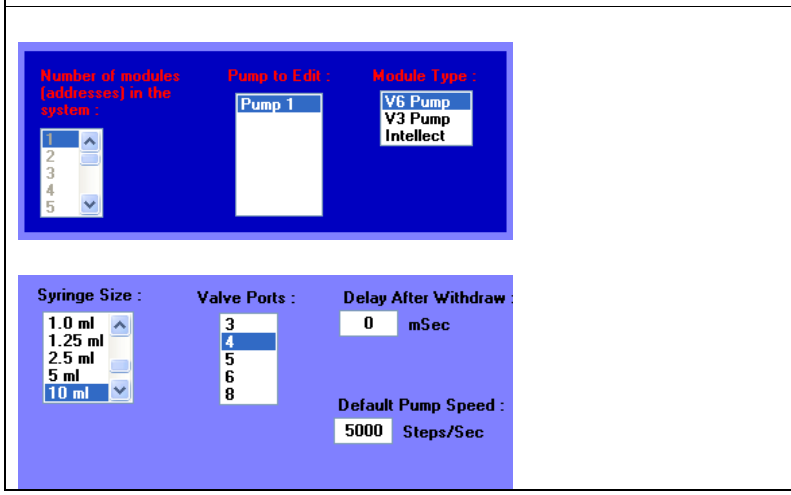

2) On the pump configuration screen, select the pump, in the Pump to Edit box, that was changed, then for that pump, specify 1) the syringe size in the Syringe Size box, 2) the number of ports on the distribution valve, 3) the Default Pump Speed, and 4) and the Delay after Withdrawal (see below).

# Pump Configuration Form

For a pump to operate correctly, the software must be programmed for its current configuration, including the number of syringe pump modules in the system, syringe sizes, the number of ports on each distribution valve, and each pumps default speed. This information is entered on the Syringe Pump Configuration screen. To open the configuration screen, select the Pump Manual Control tab, then select Pump Configuration from the Configuration menu.

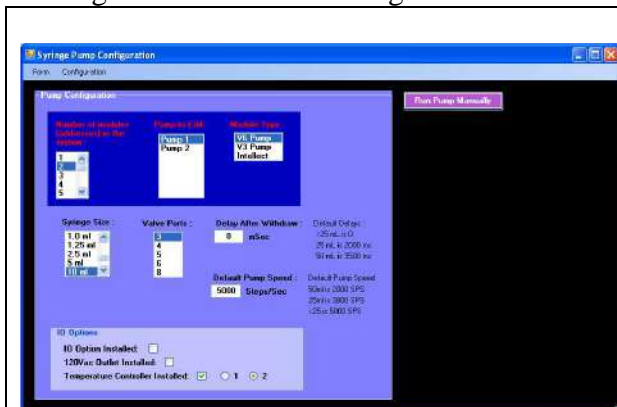

**Default Configuration Reset** – If you’re not sure how to reset the configuration of the pump, a good place to start is to reload the original pump configuration. Once reloaded, you can make any changes using the Pump Configuration Form as outlined below. To reload the original settings, select Reset to Factory Default from the Configuration menu.

**To manually change system pump system settings:**

1) First, select the number of modules (pumps) in the system. For example, if your system has two V6

- pumps and one Intellect valve unit, then select “3” for the number of modules in the system.
- 2) Once the number of modules are specified, the listbox titled *Module to Edit* populates with one title for each module position.
- 3) Select the module of interest from the *Module to Edit* box to either see or change its current settings.
- 4) With the Module of interest highlighted, first specify the type of module that it is (either a V6 pump, V3 pump, or Intellect module). If the module type is a pump, you must specify the syringe size, the number of ports on its distribution valve, a PAW delay time, and a Default speed for the pump (see later). If the module is an Intellect valve, the only parameter that needs to be set is the number of ports on the valve. PAW Delay stands for Pause After Withdrawal. For large syringes or very viscose fluids, its sometimes desirable to pause the system for a set period of time after drawing reagent into the syringe to allow the reagent to fully flow into and fill the syringe. For 25 ml syringes, the default value is 2000 ms, and for 50 ml syringes the default value is 3500 ms.
- The default pump speed is the speed the pump uses at startup. The pump maintains this speed until the speed is explicitly changes in the programs code.
- Before exiting this screen, make sure that all parameters for all of the modules are entered.
- 5) Specify the IO options installed in this system by checking the appropriate boxes.

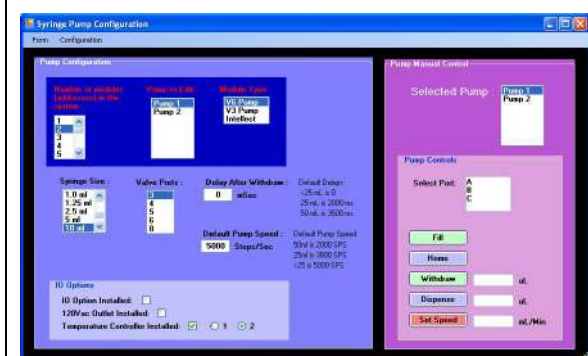

The Syringe Pump Configuration screen allows the user to control the actions of each of the syringe pumps in the system manually. Click the Run Pump Manually button to load this screen. Highlight the pump of interest in the Selected Pump box. The controls below have the affects listed on the selected pump.

**Selected Port** – Clicking on a port letter causes the pumps valve to go to the selected port.

**Fill** – Causes the syringe to fully fill.

**Home** – Causes the syringe to dispense all of its content.

**Withdraw** – Causes the pump to withdraw the volume specified in the text box to the right of the button.

**Dispense** – Causes the pump to withdraw the volume specified in the text box to the right of the button.

# Infinity Controller Configuration

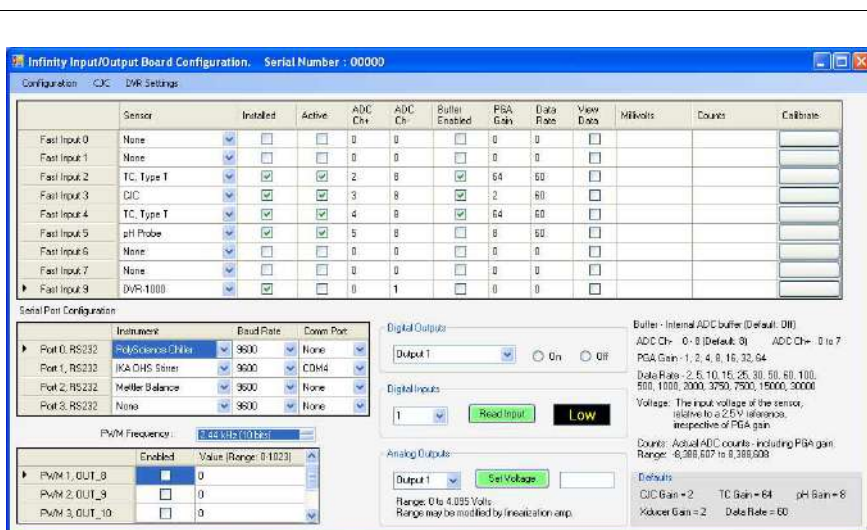

To open the configuration form, select Infinity Configuration from the Infinity menu on the Reaction Controller program tab.

The Infinity configuration form is used to define the type of analog sensors used, digital inputs and outputs and other basic configuration settings. Most of these controls are not user accessible.

## Serial Port Configuration

	Instrument	Baud Rate	Comm Port
1	PolyScience Chiller	9600	Inf, Port 1
2	IKA DHS Stirrer	9600	COMM
3	None	9600	Inf, Port 3
4	None	9600	Inf, Port 0

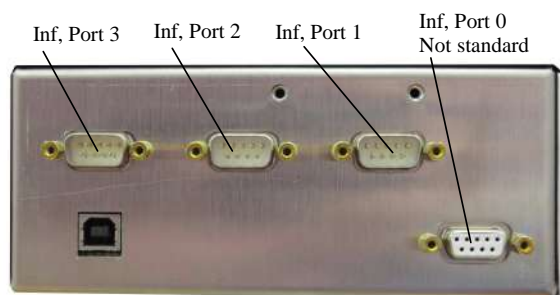

One important, user accessible, section is the Serial Port Configuration table. In this table, the user specifies what instrument is connected to what serial port on the Infinity controller. The Infinity controller has three RS232 serial ports on 9-pin connectors and three USB ports. In the column titled “Instruments”, select the instrument connected to the Infinity controller. If the instrument you want is not present in the list, contact J-KEM Scientific for assistance. Set the baud rate of the instrument, then specify the comm port the instrument is connected to in the

Comm Port column (i.e., Inf, Port \*). If serial connection to the external instrument (i.e., chillers, stirrers, etc.) is via a 9-pin RS232 serial connection, then select “Inf, Port \*” and connect the instrument to the specified 9-pin port on the side of the Infinity Controller. If the external instrument is connected via a USB port, then select “USB” from the drop down list in the Comm Port column. The instrument itself can be connected to either a USB port on the PC, or one the USB ports on the back of the Infinity Controller.

## Serial Communication Issues

Serial communication with external instruments is a very complex task, primarily because there are so many different manufactures and each manufacture uses its own unique communication protocol and command set (additionally, some manufactures do a very poor job implementing reliable serial communications). J-KEM has simplified this complex task by pre-configuring the Infinity controller with the communication parameters of the most common laboratory instruments. Three elements must be addressed to successfully communicate with an instrument through the Infinity software.

- 1) The instrument must be connected to the proper Infinity (or PC) port.
- 2) The instrument must be programmed with the correct communication parameters (like the correct baud rate). In general, the only parameter that must be set in the instrument is the baud rate. The baud rate should be set to 9600. In any case, the baud rate set in the instrument (chiller, stirrer, etc.) must be the same value specified in the Serial Port Configuration table. Contact the instrument manufacture for assistance.
- 3) **The correct cable must be used to connect the instrument to the Infinity controller.** This is very important, and is usually the source of errors. Below is a list of instruments that use non-standard cables. If you do not have the correct cable, it must be purchased.

## Instrument Specific Issues

The serial communication protocol for every manufactures instrument is different, additionally, some instruments have special cable requirements. To the degree possible, know issues with common instruments are listed below.

<p><b>IKA Stirrers</b></p> <p>Stirrers with 15-pin serial connectors – These stirrers require a custom USB to serial cable. This cable is available from J-KEM Scientific (Cat# INFC-IKA15)</p> <p>Stirrers with 9-pin serial and USB connectors – To use the 9-Pin connector, you must use the proper USB to serial cable (Cat# INFC-IKA9). To use the USB connector, you must install the VCP driver available from IKA.</p>	<p>Because of the serial communication protocol chosen by IKA, IKA stirrers must be connected directly to the PC, either a PC 9-pin serial port or a USB port.</p> <p>IKA manufactures a wide variety of stirrers, but most fall into these categories.</p>
<p><b>Julabo Chillers</b></p>	<p>These chillers require a custom 9-pin serial cable. These are available from J-KEM Scientific (Cat# INFC-Julabo9).</p>
<p><b>Huber Chillers</b></p>	<p>When available, connect a Huber chiller to the controller via a USB connection. Huber offers a USB to serial driver that must be loaded on the PC before this connection will be detected by the Reaction Controller. These chillers require a custom 9-pin serial cable. These are available from J-KEM Scientific (Cat# INFC-Huber9).</p>
<p><b>Heidolph RZR Stirrers</b></p>	<p>These stirrers require a custom 15-pin serial cable. These are available from J-KEM Scientific (Cat# INFC-Heidolph15).</p> <p>Serial commands for four RZR models are implemented, the models 2051, 2052, 2102, and 2012Z. Each of these stirrers have different speed ranges. It is the user's responsibility to not send a speed outside of the stirrer's range. In the case of the Model 2102 stirrers, the user must manually place the stirrer in Speed range I or II using the stirrers front panel controls before starting a run with the Infinity controller.</p>
<p><b>Lauda Chillers</b></p>	<p>Connect the USB port on the chiller to a USB port on the Reaction Controller or directly on the PC.</p>

<b>AceGlass Stir Controller</b>	Connect the USB port on the motor controller to a USB port on the Reaction controller or to a PC USB port. The default baud rate of the motor controller is 115,200. Both the motor controller and the infinity controller must be set to this baud rate.
<b>ChemStir by ChemGlass</b>	Either the USB port or the RS232 port can be used for communications. If the USB port is used, connect the USB port on the motor controller to a USB port on the PC or on the Infinity controller. If the RS232 port is used, connect the RS232 port on the motor controller to one of the RS232 ports on the side of the Infinity controller. Make sure that the serial connection switch on the ChemStir controller is set to the serial port in use.